

Asian Institute of Technology
Annual Report on
Research 2010

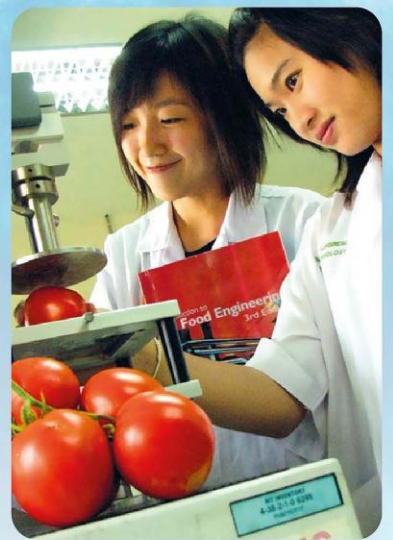

AIT
Asian Institute of Technology

PREFACE

The Asian Institute of Technology will need to face up rapid dynamic changes as it moves into the future. It will have to adapt to rapidly changing needs in the region, funding mechanisms, student demands and employability, creation of public and privately supported graduate schools, provide better compensation to faculty and staff, enhance campus and laboratory infrastructure, develop professionally run professional programs, initiate new knowledge areas, etc. While the present administration has taken some steps and have plans to meet up with others, a few overriding factors will have to be kept in mind. This will most certainly centre around the quality of our academic and research programs and the investment needed to further strengthen the same. While accreditation by professional bodies, planning for distant learning modules, etc. will be the needed in the future for our academic programs, in the area of research and development we will need to develop some niche areas in which we will be recognized and accepted to be amongst the front runners in the world.

It is with background that we have been working on the AIT Research Strategy for the next five years. This will be based on four principles, namely, Research Focus, Research Quality, Research Collaboration and Research Resource Mobilization. The work plans required to achieve the stated overall outcomes, measurable outputs, key performance indicators, etc are being developed using a Results Based Management (RBM) approach. The focus of research has been identified to be the umbrella area of "Sustainable Development in the context of Climate Change (SDCC)" with five identified thematic areas under its purview. It is hoped that will help create stronger inter-disciplinary teams that can form better networks both internally and with external partners. This will allow the institute to focus on some areas of research and competitively bid and win larger projects, which in turn will make possible better research outputs and infrastructure. It is hoped that this will be used in the future to hold discussions with various stake holders which will include donors, government agencies and the private sector so that AIT can serve as a platform for innovative research and development.



While the number of research projects and related funding has nearly doubled, based on year 2005, in the last two years this has leveled off. The reasons for this include smaller number of research faculty and staff, closing down of some major long term projects, needs to win projects in competition, changing demands and mode of operation of funding agencies, etc. This strengthens our belief to form larger interdisciplinary teams and need for partnerships. This is a challenge which all sectors of AIT are facing up to and will most certainly overcome.

We take this opportunity to thank all faculties, staff, students and indeed all stake holders who made it possible for us to bring financial stability to the institute. With the institute on the verge of becoming formally and international-intergovernmental organization and a number of initiatives being planned, it is hoped the institute will be able to sustain itself into the next 50 years. We look forward to increased collaboration and partnership to expand the knowledge base we have created and improve the quality of life of those who those most need it.

*Professor Sudip K Rakshit
Vice President for Research
21st June, 2011*

TABLE OF CONTENTS

PREFACE	i
TABLE OF CONTENTS	iii
Chapter 1: INTRODUCTION	7
Chapter 2: RESEARCH STATISTICS AND TRENDS, 2005-2010	9
Chapter 3: SNAPSHOTS OF AIT RESEARCH IN 2010	11
Chapter 4: SCHOOL OF ENGINEERING AND TECHNOLOGY	23
4.2: SET – COMPUTER SCIENCE and INFORMATION MANAGEMENT FIELDS OF STUDY	27
4.3: SET – CONSTRUCTION ENGINEERING AND INFRASTRUCTURE MANAGEMENT FIELD OF STUDY	33
4.4: SET – GEOTECHNICAL & EARTH RESOURCES ENGINEERING FIELD OF STUDY	37
4.5: SET – INDUSTRIAL AND MANUFACTURING ENGINEERING FIELD OF STUDY	43
4.6: SET – MECHATRONICS and MICROELECTRONICS & EMBEDDED SYSTEMS FIELDS OF STUDY	49
4.7: SET – NANOTECHNOLOGY FIELD OF STUDY	53
4.8: SET – REMOTE SENSING AND GEOGRAPHIC INFORMATION SYSTEMS FIELD OF STUDY	59
4.9: SET – STRUCTURAL ENGINEERING FIELD OF STUDY	63
4.10: SET – TELECOMMUNICATIONS FIELD OF STUDY	69
4.11: SET – TRANSPORTATION ENGINEERING FIELD OF STUDY	75
4.12: SET – WATER ENGINEERING AND MANAGEMENT FIELD OF STUDY	79
4.13: SET – INFORMATION AND COMMUNICATIONS TECHNOLOGIES AREA OF STUDY	87
4.14: SET – OFFSHORE TECHNOLOGY AND MANAGEMENT PROGRAM	89
Chapter 5: SCHOOL OF ENVIRONMENT, RESOURCE AND DEVELOPMENT	91
5.2 SERD – AGRICULTURAL SYSTEMS AND ENGINEERING FIELD OF STUDY	93
5.3: SERD – AQUACULTURE AND AQUATIC RESOURCES MANAGEMENT FIELD OF STUDY	97
5.4: SERD – ENERGY FIELD OF STUDY	101
5.5: SERD – ENVIRONMENTAL ENGINEERING AND MANAGEMENT FIELD OF STUDY	109
5.6: SERD – FOOD ENGINEERING AND BIOPROCESS TECHNOLOGY FIELD OF STUDY	123
5.7: SERD – GENDER AND DEVELOPMENT STUDIES FIELD OF STUDY	129
5.8: SERD – NATURAL RESOURCES MANAGEMENT FIELD OF STUDY	133
5.9: SERD – PULP AND PAPER TECHNOLOGY FIELD OF STUDY	137
5.10: SERD – REGIONAL AND RURAL DEVELOPMENT PLANNING FIELD OF STUDY	141
5.11: SERD – URBAN ENVIRONMENTAL MANAGEMENT FIELD OF STUDY	145
5.12: SERD – AGRIBUSINESS MANAGEMENT PROGRAM	151
5.13: DISASTER PREPAREDNESS, MITIGATION AND MANAGEMENT AREA OF STUDY	153
5.14: GENDER, TRANSPORTATION AND DEVELOPMENT AREA OF STUDY	157
Chapter 6: SCHOOL OF MANAGEMENT	159
Chapter 7: AIT EXTENSION	171
Chapter 8: INTERNET EDUCATION AND RESEARCH LABORATORY (intERLab)	177
Chapter 9: AIT – VIETNAM	181
Chapter 10: CENTERS OF EXCELLENCE AND OUTREACH	187
10.1: CENTER OF EXCELLENCE ON SUSTAINABLE DEVELOPMENT IN THE CONTEXT OF CLIMATE CHANGE (Coe SDCC)	187
10.2: ASEAN REGIONAL CENTER OF EXCELLENCE ON MILLENNIUM DEVELOPMENT GOALS (ARCMDG)	190
10.3: CSR ASIA CENTER AT AIT (CSRACA)	195
10.4: YUNUS CENTER	200
Chapter 11: INSTITUTE-WIDE SPONSORED AND CONTRACTED PROJECTS	203
11.1 Grants and Sponsored Research Completed in 2010	203
11.2 On-going Grants and Sponsored Research	203
Chapter 12: OVERVIEW OF RESEARCH ACTIVITIES FOR 2010 AND STUDENT COMPETITIONS	205
12.1 OVERVIEW OF RESEARCH ACTIVITIES FOR 2010	205
12.2 STUDENT COMPETITIONS	207
12.2.1 MASTERS THESIS COMPETITION 2010	207
12.2.2 AIT V.RESEARCH COMPETITION 2010	208



Chapter 1: INTRODUCTION

1.1 AIT Mission

The Asian Institute of Technology promotes technological change and sustainable development in the Asian-Pacific region through higher education, research and outreach. Established in Bangkok in 1959, AIT has become a leading regional postgraduate institution and is actively working with public and private sector partners throughout the region and with some of the top universities in the world.

Recognized for its multinational, multi-cultural ethos, the Institute operates as a self-contained international community at its campus located 40 km (25 miles) north of Bangkok, Thailand.

Besides the usual laboratories and academic buildings, the main campus includes housing, sports, and medical facilities, a conference center, and a library with over 230,000 volumes and 830 print and on-line periodicals. All serve to fulfill **the AIT mission** -

to develop highly qualified and committed professionals who play leading roles in the region's sustainable development and its integration into the global economy.

1.2 AIT Vision

To become a leading and unique regional multicultural institution of higher learning, offering state-of-the-art education, research and training in technology, management and societal development.

With this clear, timeless vision, the multi-skilled team of students, faculty and staff at AIT are set to continuously strengthen the institution by becoming

- A trailblazer in advanced education in the region, with leadership in IT and new types of multidisciplinary programs.
- An exemplary institution, with an emphasis on academic quality in terms of courses and other aspects of the operation.
- A leader in professional development programs.

- A hub for the implementation of regional/transnational research projects, and a research facility for academic professionals. The hub will network with other academic and research institutions in the region and the world.
- A model international citizen.
- A collaborator and partner of national postgraduate institutions.
- A financially viable, self-sustaining institution, able to draw support from donors, the private sector and individuals, with good governance and strong leadership.
- A strong partner to its alumni, who are principal stakeholders through the AIT Alumni Association (AITAA)



Chapter 2: RESEARCH STATISTICS AND TRENDS, 2005-2010

2.1 Project Numbers and Budget 2005-2010

In line with the desire to impact on society by integrating academic research with industry and society's needs, AIT witnessed a good growth in the numbers of sponsored and contracted projects undertaken and that of publications between 2005-2010. **Figure 2.1** gives an overview of the trend of the ongoing sponsored and contracted projects for the period 2005-2010 both in and budget value terms and in terms of the number of ongoing projects undertaken during the same period.

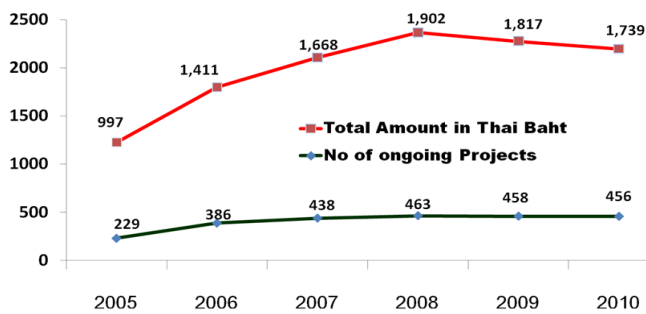

Figure 2.1: Project Budget is identified in Million ('000,000) Thai Baht.

2.2 Trend of the Ongoing Projects by Category

Sponsored and contracted projects undertaken at AIT are assigned under the Fund 30 which are categorized as Research and development which comprises Research, Capacity Building, Networking/Coordination, Training/Workshop and conference projects. The Academic Programs category comprises newly initiated Professional programs conducted by the different schools and AIT Extension category comprises continuing professional education, short-course training and consultancy services. **Figure 2.2** provides the trend for the period 2005 – 2010 on budget value terms and **Figure 2.3** give the trend in terms of the number of ongoing projects under each category.

Publications over the years has seen an increase in the requirements in order to enhance quality of research from a time about a decade ago when doctoral students had only to submit a manuscript of a Paper before graduation, today all such students need to show acceptance of paper by an international and referred journal before they graduate. Publications in refereed Journals as one measure of productivity in the academic spheres increased with a high margin between 2009 and 2010 this .Discussions are being held

to include additional criteria towards ascertaining the impact of such papers. **Figure 2.4** shows the trend of publications under the categories namely Referred Journal Publications, Doctoral Thesis, Master's Thesis as well as completed projects for the period 2005-2010.

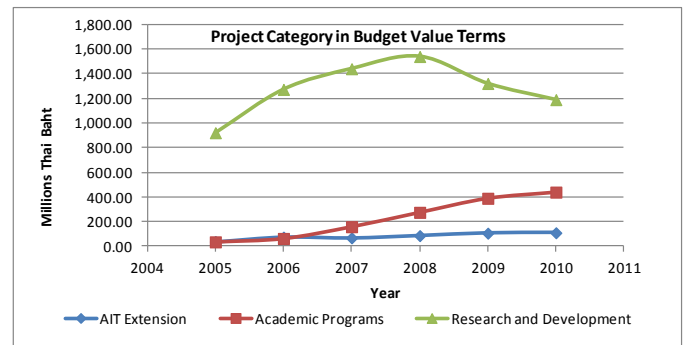

Figure 2.2

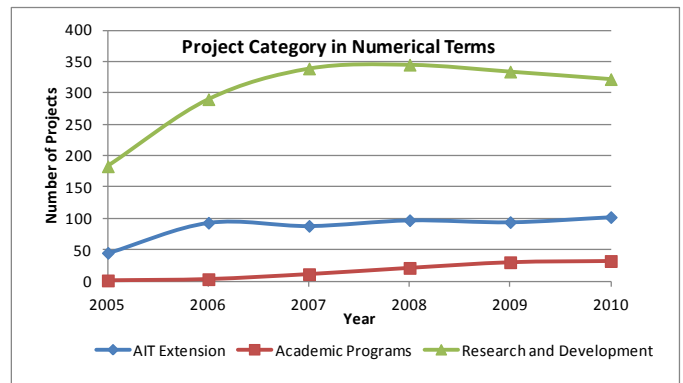

Figure 2.3

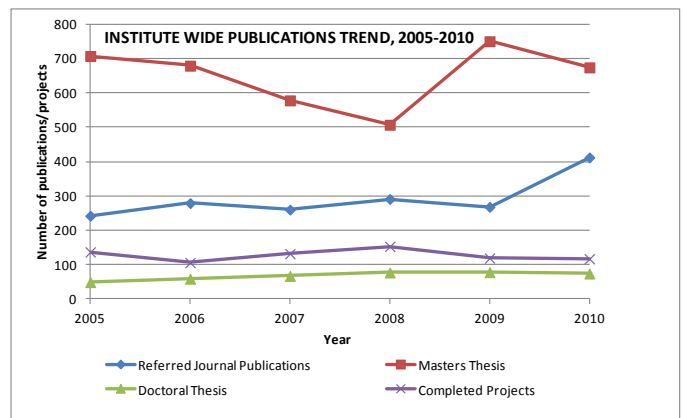

Figure 2.4

Over the years there has been a reduction in seconded faculty (supported by different countries). This led to a reduction in the total full time faculty (as they were not all replaced by direct hire faculty) and highlights the tremendous effort put in by our faculty and research staff. There has also been a subsequent increase in adjunct faculty who offer specialized courses and professional programs. **Figure 2.5** below shows the trend in the Faculty strength grouped as Full time faculty and total faculty including adjunct, affiliated, visiting faculty, etc.

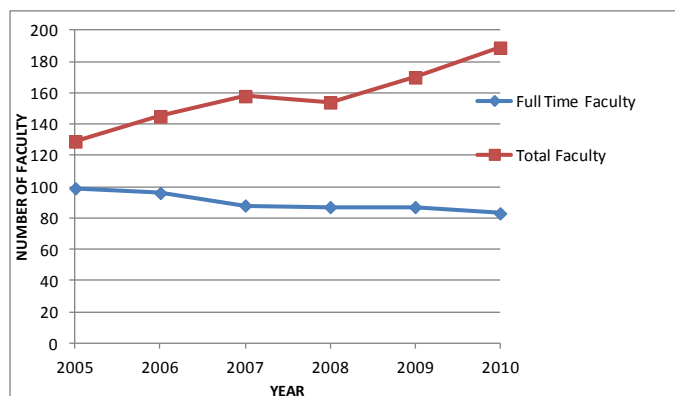

Figure 2.5: Faculty Strength 2005- 2010

Research excellence in an international institution of higher learning as AIT is linked with the graduate students we have. **Figure 2.6** gives an institute wide trend on the intake, Enrolment and graduated student strength for the period.

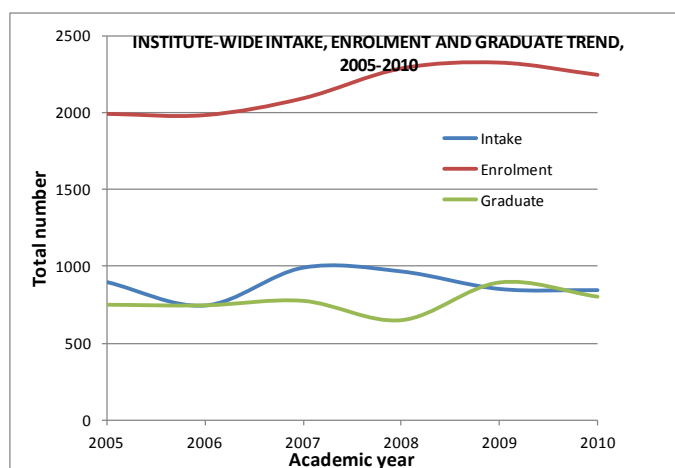

Figure 2.6

2.3 Most Cited Papers in Scopus

Publication and citation information is considered one of the most widely recognizable indicators of research output and quality, and collection and analysis of this information is among means to judge alignment of the institutions research activities with its strategic priorities. **Table 2.1** below shows the top 5 most cited publications in Scopus lifetime. It is planned to have a year on year analysis in due course.

1. [On the acceptability of arguments and its fundamental role in nonmonotonic reasoning, logic programming and n-person games \(Cited 549 time\(s\)\)](#); 1995; Artificial Intelligence; Dung, P.M.
2. [Direct solid-liquid separation using hollow fiber membrane in an activated sludge aeration tank \(Cited 261 time\(s\)\)](#); 1989; Water Science and Technology; Yamamoto, K., Hiasa, M., Mahmood, T., Matsuo, T.
3. [Developments in industrially important thermostable enzymes: A review \(Cited 181 time\(s\)\)](#); 2003; Bioresource Technology; Haki, G.D., Rakshit, S.K.
4. [An abstract, argumentation-theoretic approach to default reasoning \(Cited 141 time\(s\)\)](#); 1997; Artificial Intelligence; Bondarenko, A., Dung, P.M., Kowalski, R.A., Toni, F.
5. [Membrane separation bioreactors for wastewater treatment \(Cited 136 time\(s\)\)](#); 2000; Critical Reviews in Environmental Science and Technology; Visvanathan, C., Ben Aim, R., Parameshwaran, K.

Table 2.1

2.4 Top 5 Researchers with the Highest Number of Projects initiated 2006-2010

The streamlining of Project management and corresponding incentives towards initiation of projects has helped reinforce the institutions research objectives and focus. **Table 2.2** highlights the top Researchers with the Highest Number of Projects initiated 2006- 2010.

Name	Number of Projects as PI	No. of Projects as PI and Co-PI
Kanchana Kanchanasut	48	49
S. Kumar	11	27
Mukand S. Babel	22	25
C. Visvanathan	21	24
Sudip K. Rakshit	19	23
Kunnawee Kanitpong	18	22

Table 2.2

Chapter 3: SNAPSHOTS OF AIT RESEARCH IN 2010

Overall during the period January - December 2010 there were a total of 449 sponsored and contracted projects conducted by the faculty and staff at AIT's School of Engineering and Technology (SET), School of Environment, Resources and Development (SERD), School of Management (SOM), as well as at AIT Extension, InterLab, and numerous other Institute-wide projects and centers. The total number publications for the same period stood at 691 from across AIT. The following (below) are brief snapshots of research conducted at AIT in 2010. Full details of all research conducted at AIT in 2010 can be found in AIT Research Annual Report 2010.

3.1 **POLICE EYES: Portable Traffic Violations Detector**

Dr. Mongkol Ekpanyapong

School of Engineering and Technology

Automobile accidents incur an extremely heavy toll on human lives and society. They also have great impact on the economy. According to the World Bank, the economic impact of automobile accidents in Thailand is a loss of more than 200 billion baht per year. Many accidents could be prevented if drivers obeyed traffic regulations. This research study is designed as a portable system capable of automatically detecting traffic violations and either sending a letter to warn the driver, and thereby informing nearby authorities, or automatically issuing traffic violation tickets. The system is composed of an embedded system, a radar system, a video camera system, a GPS system, and a WIFI communication device packaged as a portable system. The radar system is used to check for speeding vehicles, while the video processing algorithm is used in conjunction with radar measurement to reduce false positive errors in the radar measurement and to detect vehicles crossing lane boundaries. By enhancing our ability to detect and prevent traffic violations, the proposed system has the potential of economic benefits through lowered health care costs and higher productivity by reducing accident rates.

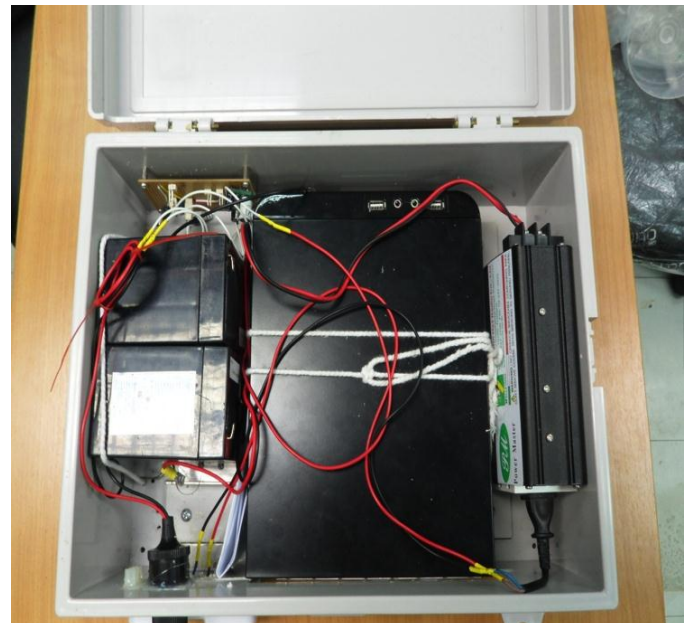

Portable Traffic Violations Detector

3.2 Automated Test Equipment

Dr. Nitin Afzulpurkar

School of Engineering and Technology

In the increasingly competitive hard disk drive industry, all manufacturers need to aggressively develop their products to survive. Not only must they invest in research and development of products themselves; but also in advanced automation technology to use the new equipment in manufacturing processes to improve cycle time, productivity and flexibility of the production system. Automated Test Operation (ATO) found at the back end area of disk drive manufacturing is one of the operations that make use of advanced automation test equipment and technology to create more efficiency and effectiveness. ATO is a complex operation that is difficult for planning, monitoring and forecasting. It cannot quickly manage a production system to compensate for external demands and internal disturbances. The modeling of manufacturing systems can be used as a representation of complex systems like an automated test operation. The manufacturing models are used as a tool for monitoring, forecasting and controlling of a represented system. In this research, soft computing solutions were developed by using artificial neural networks, integrating with another artificial tool to simulate automated test equipment models to solve the complexity of disk drive test operation.

Automated Test Equipment

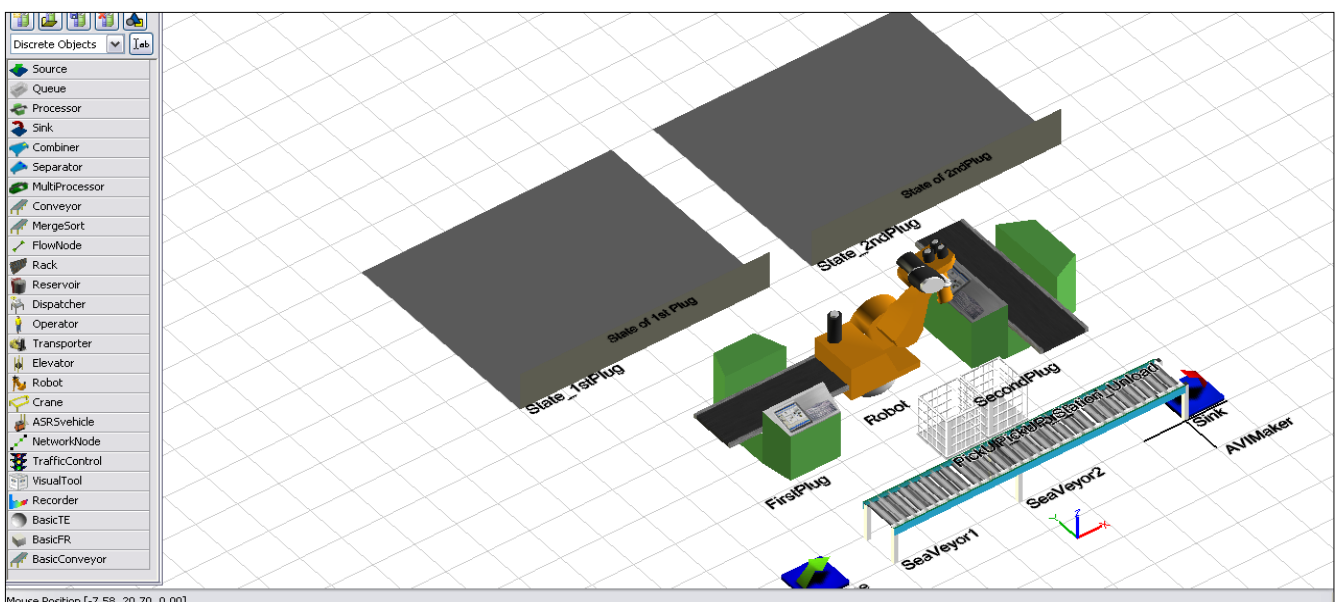
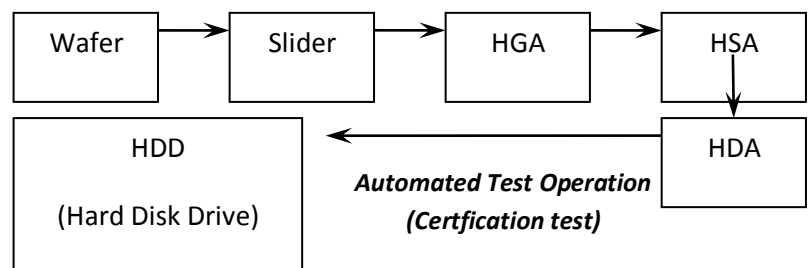

3.3 Air Quality and Climate Impacts of Switching to Natural Gas-Fueled Public Transportation Vehicles in Bangkok

Prof. Nguyen Thi Kim Oanh, Dr.Eng.
School of Environment, Resources and Development
Rattapon Onchang, Dr.Techn.
Department of Environmental Science
Faculty of Science, Silpakorn University

AIT and Silpakorn University cooperated in this project Both worked with the Royal Thai Government to assess the multiple impacts of the fuel-switching on air quality, climate, human health and economic with a particular focus on switching to Compressed Natural Gas (CNG) in the public transportation system in the Bangkok Metropolitan Region (BMR) as a case study.

The study presented two scenarios projected to 2015 and 2025, wherein a switch to using CNG and advanced vehicle technologies for public transport vehicles in the BMR was key. These scenarios were compared to current model (business-as-usual).

Methods included surveying of the situation and planned programs, emission inventory for air pollutants and climate-forcing forcers agents for the base year of 2009 and emisison projection projected to 2015 and 2025 through using the International Vehicle Emission (IVE), and simulation of ambient air quality by a 3D dispersion air quality model, the Comprehensive Air Quality Model with extensions (CAMx).

The potential financial benefits from the emission reductions were preliminarily assessed. A feasibility study was also implemented using the Certified Emission Reductions (CERs) based on the Clean Development Mechanism (CDM) project approach to explore potential financial benefits from the emission reductions.

Substantial reductions of both air pollutants (COPM10, CO, VOC, VOC evaporative, and NOx and PM10) and climate forcing forcersagents (CO2, N2O, CH4, VOC, VOC evaporative, NOx, Black Carbon and Organic Carbon particles) would be achieved in both scenarios as compared to the business as usual, which justify the co-benefits gained from the switch. The results revealed relatively small reductions in ambient concentrations of both air pollutants and climate forcing agents. Through Certified Emission Reductions (CERs) trading, it is also possible to gain about 2.2 2,158,809 and 2.9 2,882,906 million US\$/year, for years 2015 and 2025 respectively.

A relatively high investment is necessary to support the switch, such as engine modification and new engine technology, which must be studied further by the Royal Thai Government.

Possible health benefits associated with the air pollutants reduction could further be explored in terms of morbidity and mortality reduction of the population in BMR.

3.4 Energy Security in Developing Countries: National and Household level vulnerability and challenges

Prof. R. Shreshta, Prof. S. Kumar.
School of Environment, Resources and Development
Rattapon Onchang, Dr.Techn.
Department of Environmental Science
Faculty of Science, Silpakorn University

The challenges posed by potential supply disruptions and high price rises of fossil fuels to the economic growth are common to both developing and developed countries. Energy security, defined by The World Energy Assessment Report, as “the continuous availability of energy in varied forms in sufficient quantities at reasonable prices” may well reflect developed countries’ perspectives, but does not adequately capture the energy security dimensions faced by developing countries, as there are several additional dimensions that are unique to developing countries. The GNESD, through its member centers, has been analyzing energy security issues, both from the national and household sector perspectives, from developing countries’ perspectives.

The characteristics - in terms of the nature of energy security issues of developing countries, vulnerability and threats at national and at household level, and policies and measures in these countries to address the energy security - were the objectives of this research.

As an important dimension of energy security, easy availability of reasonable amount of clean/modern energy is considered a basic necessity to reduce poverty and improve the living standards. (Eg. energy policies of India and South Africa.) The following factors are mainly identified behind the vulnerability and the threats to energy security:

- Growing reliance on imported energy as most countries rely on imported energy. Energy price rise could, therefore, have a crippling effect on the economy and overall development for most countries under the study. Also, countries have initiated several kinds of programs to reduce the impact of imported energy, including replacement of petroleum products by biofuels promotion of renewable energy, and energy efficiency.
- Primary energy source diversification. The diversification of primary energy supply (Shannon Weiner index) shows improvements during the recent past in Thailand, Brazil, Tunisia, India and South Africa, and is comparable to OECD countries. In electricity generation sector, however, many countries depend to a large extent on a single source

[South Africa (coal > 0%), Tunisia (natural gas >88%), Senegal (thermal >90%), Brazil (hydro >70%), Kenya (hydro >50%) and India (coal >50%)].

- Energy demand and supply. The energy demand in developing countries is likely to increase substantially in the course of their development, and its use is also to move up the energy ladder. So, the sources of primary energy used are likely to shift from predominance of traditional use of biomass to that of modern commercial energy (fossil fuels and modern use of biomass). Several countries in South America have relatively abundant energy resources. However, lack of access to and regional (provincial) disparity of cleaner and convenient energy use appears to a large extent due to inadequate energy policies or policy failures.
- Reliance on non-marketed sources of energy. Substantial fraction of the population and industries in the countries under the study rely on non-marketed sources of energy (e.g. collected biomass) and this high dependence is likely to continue for a foreseeable future. The energy supply problem is compounded by the fast decreasing forest resources in many countries.
- Investment in energy sector. Considerable amount of investment would be required for resource exploration, infrastructure development (generation, supply and distribution systems) and supply of modern commercial energy. As investment by government alone would not be able to fulfill the required investment, several countries have adopted policies to attract private investment.
- The energy security-related vulnerabilities and threats in the household sector in the countries under the study have the following characteristics:
 - Energy costs: Energy costs form a significant share of total household expenditure (especially low income households') in many developing countries (about 20% in South Africa and Thailand, and up to 40% in Kenya). Thus any significant rise in energy prices could have serious adverse effects on the poor families.
 - Energy access. There also exists big inequity in many developing countries in terms of access to modern and safe energy between the poor and rich. Though access to electricity is very high in some countries (Thailand, Tunisia, Argentina, Brazil), in others the level of electrification is low (in Kenya, access to electricity in households is about 15%, while only about 8% of households have access to LPG supply).
 - Lack of a reliable and sustainable supply of energy impacts the quality of energy services provided to households. In some countries, the residential sector has the highest share of the national energy consumption (Kenya at 77%)

- Dependency on biomass. Biomass energy use remains high in most developing countries, especially those in the low income category. The household sector is the major user of biomass. In countries where options other than biomass are either not available or not affordable, ensuring sustainable supply of biomass energy presents a major energy security challenge.

Countries under the study have formulated policies and initiated measures to address the threats to energy security through country specific programs. (Eg. promotion of renewables, energy efficiency, private sector investment, developing regional cooperation, developing strategic reserves.)

Centers Participating in the Energy Security Study

Africa:	The African Energy Policy Research Network/Foundation for Woodstove Dissemination (AFREPREN), Kenya; Energy Research Center (ERC), South Africa; Mediterranean Renewable Energy Centre (MEDREC), Tunisia; Environmental Development Action in the Third World (ENDA-TM), Senegal.
Asia:	Asian Institute of Technology (AIT), Thailand; The Energy and Resources Institute (TERI), India.
South America:	Janeiro and CENBIO at the University of Sao Paulo in conjunction, Brazil; The Institute for Energy Economics at Bariloche Foundation (FB), Argentina.

The complete reports of each centre and the synthesis report is available at www.gnesd.org.

3.5 Pavement Surfaces with Higher Solar Reflectivity

Dr. Kunnawee Kanitpong

School of Engineering and Technology

Bangkok, like many cities in the world, encounters significantly increasing challenges of higher temperatures due to the urban heat island phenomenon. Using traditional building materials such as asphalts and concrete for roads and other infrastructure is among the key factors causing the air temperature in the city to be higher compared to that in surrounding areas. This is due to the absorption of the solar radiation and hence the radiation of excess heat during the day and at night. Increases in the pavement temperature causes the ambient temperature to rise, which in turn increases energy costs for air conditioning and damages air quality in the city. One way to address this problem is to provide pavement surfaces with higher solar reflectivity or albedo for roads. The measurement of albedo over 106 asphalt pavement sections and 43 concrete pavements sections across Bangkok Metropolitan Area revealed that the albedo of both pavement types were quite low, i.e., less than 0.10. This result indicates an opportunity to increase pavement's albedo through various surface treatment methods. Examples of these methods include coating with grey or tan emulsion sealcoats, resurfacing with lighter colour chipseals, and overlying with concrete white-topping. The choice of materials determines albedo increase, and materials with lighter shades correlate to the higher albedo and lower surface temperature. The lightest available was shown to reduce maximum surface temperature by 7 to 14 degrees C.



3.6 Physical Model for Monkey Cheeks

Dr. Sutat Weesakul

School of Engineering and Technology

The Monkey Cheek project in the MahachaiSanamchai canals performs the function of storing flood waters in the upper areas, while at the same time releasing water into the Gulf of Thailand in relation to the tide levels of the sea by relying on the appropriate use of gravity and pumping stations. The project comprises construction of regulators and pumping station in canals, which yield considerable benefits without requiring huge investments. It can be linked with the Monkey Cheek project in the lower Tha Chin River to form an integrated system for efficient flood alleviation in Bangkok.

Dr. Sutat Weesakul is Principal Investigator of the project. AIT has been rendering its service towards the study, which is apart of the overall project to be carried out by Hydro and Agro Informatics Institute (HAI) for the Chaipattana Foundation. H.R.H. Princess Maha Chakri Sirindhorn is the executive chairperson of the Chaipattana Foundation.

AIT has been responsible for constructing the physical model and performing the function of storing flood water not only in the upper areas, but also in the ponds donated by local people and the golf course. The main objective is to provide the appropriate procedure for operating all regulators and pumping stations so that they are in harmony with natural conditions.



3.7 Physical Hydraulic Model Study of the Xayaburi Hydroelectric Project

Dr. Sutat Weesakul

School of Engineering and Technology

The Xayaburi Hydroelectric Power Project will be constructed across the lower Mekong River mainstream just upstream of Baan Pak Neun district in the northern province of Xayaburi, Lao, PDR .

From right to left abutment, the dam construction consists of the following main components and structures:

- A navigation system placed at the extreme right abutment and partially cut into the right bank slope.
- An overflow spillway, equipped with ten (10) radial gates each 19 m wide and 21 m high, with upstream and downstream stoplogs and associated cranes.
- An intermediate block that separates the spillway from the powerhouse complex and houses the powerhouse unloading and erection areas as well as part of the fish passing facilities.
- An intake-powerhouse complex with eight (8) Kaplan generating units including all electro-mechanical and hydro-mechanical auxiliary equipment and systems. The intake-powerhouse complex also includes eight (8) sand flushing outlets and part of the fish passing facilities.
- A fish ladder facility for upstream fish migration on the extreme left abutment.

The normal headwater level of the Project is established at an elevations of 275m, following the criterion to limit the raising

of the water levels at Luang Prabang during flood conditions to acceptable levels. The maximum powerhouse outflow established through economic optimization is 5,000 m³/s, while the spillway capacity is designed up to the PMF estimated at 47,500 m³/s.

In order to ascertain the most critical hydraulic aspects of the Project, a physical hydraulic model study was commissioned at the AIT Hydraulics Laboratory by the Project Owner, Ch. Karnchang Public Company Limited in an agreement dated 15 May 2009. The physical models were built and investigated following the "Specification for the Physical Hydraulic Model Studies of Xayaburi HEPP" issued by the Project Engineer, AF-Colenco Limited on January 2009.

Physical Hydraulic Model Study of the Xayaburi Hydroelectric Project

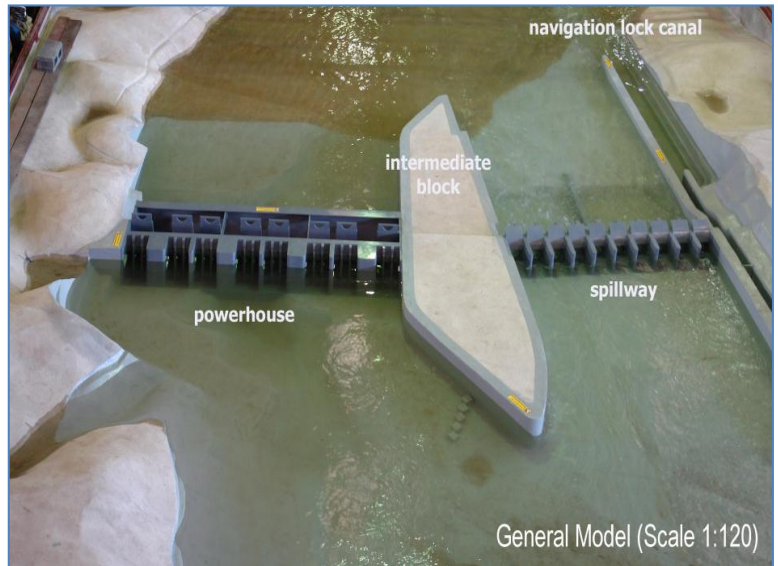

3.8 EU-Asia Link Project Gender and Sustainable Development: Natural Resource Management, Migration and Multi-local Livelihoods

Dr. Bernadette P. Resurreccion
School of Environment, Resources and Development

The links between gender, natural resource management and migration are becoming more visible in many regions, particularly regarding their role in fostering (or undermining) local forms of sustainable development. The emerging body of literature on the impacts of internal and international migration processes highlights the significance of gender and its intersections with other social structures in natural resource management and sustainable livelihoods. The experiences of Europe and Southeast Asia provide some interesting pointers for a

comparison of similarities as well as differences. Policy responses can benefit from cross-cultural learning, a process which requires bridging knowledge gaps pertaining to these fields. The key actors in both these regions, including governments, practitioners and academics share, an interest in bridging these gaps of knowledge in the policy field to (a) ensure gender equitable resource management, (b) minimise incidences of "distress entry" to migratory networks leading to exploitation and human rights abuse, and (c) ensure protected migration practices, security of livelihoods and sustained forms of local development. The Asia-Link Project offers an excellent opportunity to fill the gaps of knowledge through enhancing the mutual intellectual, social and economic co-operation between the EU and Southeast Asian regions. The Asia -Link project aimed to develop a range of collaborative South-South and North-South activities to strengthen collective institutional capacity in higher education involving programme and curriculum development, training and skills-transfer, and dissemination through conferences, workshops. To this aim, the Institute of Social Studies (ISS), the Netherlands, Andalas



University, West Sumatra, Indonesia, the Asian Research Centre for Migration (ARCM) of Chulalongkorn University, Thailand, the Asian Institute of Technology (AIT), Thailand and Brighton University, the United Kingdom combined forces.

Collaborative experiences in substantively significant cross-cutting fields of these 5 partners enriched the quality of the programme. They will jointly provide valuable expertise for future guidance in the following specific areas:

- 1) The focus of the Asian-European network of academic institutions will be on the enhancement of human resources in higher education to improve activities in policy research, advice and training on gender, natural resource management, migration and security of livelihoods;
- 2) The collaboration addresses the intersections between the following policy fields: gender and natural resource management, gender and migration, gender and sustainable livelihoods;
- 3) Commitment and support from the partner academic institutions will bridge the existing knowledge gaps and enhance the role of higher education in policy research, training and advice.

The activities in this project are as follows:

- 1) An exchange student program involving the 5 partner universities.
- 2) Workshops held in various partner universities and an international conference in the Hague.
- 3) Joint publications and extended networks beyond the project period.

At the Asian Institute of Technology:

- 1) 3 Ph.D students were sent to the University of Brighton, UK, Institute of Social Studies, the Netherlands and Andalas University, Sumatra, Indonesia for 2-3 months;
- 2) 1 MSc student was sent to ARCM, Chulalongkorn University;
- 3) One migration workshop was held in November 2010;
- 4) Five post graduate students were received from 3 partner universities (Andalas University, University of Brighton, Institute of Social Studies).

3.9 Seismic Vulnerability and Risk Assessment of Dhaka, Chittagong, and Sylhet City

Dr. Pennung Warnitchai

School of Engineering and Technology

This project is a part of the Comprehensive Disaster Management Program of the Government of Bangladesh, which was funded by UNDP, DFID, and the European Commission.

The implementation of program activities was carried out by an international consulting team consisting of Asian Disaster Preparedness Center, Asian Institute of Technology (AIT), National Society of Earthquake Technology of Nepal, Oyo International Corporation, and several leading academic institutions of Bangladesh. AIT was responsible for the seismic vulnerability and risk assessment of three major cities—Dhaka, Chittagong, and Sylhet. In this project, detailed information about buildings, essential facilities, population, lifelines, and transportation networks were first collected and acquired from several sources, and field surveys of more than 20,000 buildings were carried out. Based on these collected data, a comprehensive set of GIS maps describing the existing conditions of these cities were then developed. The seismic vulnerability of more than 40 representative building types was also determined through the use of advanced numerical analyses. Potential economic and social losses in the three cities from various possible earthquake scenarios were finally estimated using a GIS-based software package named “HAZUS”. The obtained results were used for developing a national contingency plan for earthquake disaster management of Bangladesh.



3.10 Consumer Judgment of the Quality of Food: Do quality labels help?

Dr. Rian Beise-Zee
School of Management

Consumers commonly have a problem with correctly assessing the quality of food produce. Recent food scares have lessened the confidence of consumers in guessing food quality by visually inspecting, touching and smelling food produce at open air “wet” markets. Yet, consumers can either rely on their own ability to identify quality and select the best quality or best quality-price relationship or they can trust others, in particular the retailer, the brand or a third party that certifies or endorses the product. These indirect or extrinsic quality cues become more important. In Thailand, there are now a seemingly myriad quality labels from different labeling authorities and organizations. Do they convince consumers about the food quality?

On behalf of the UNFAO, we studied consumer quality judgments using a decision-based method called conjoint measurement. The rationale for this method is that it is assumed that respondents are not able to realistically estimate how important each attribute is for them. Instead, just like real life they are asked to make judgments for product bundles which implicitly require trade-off decisions. Conjoint measurement assumes that each product evaluated by a consumer can be represented by an additive combination of separate utilities existing for the individual attribute levels.

The most important conclusion of this study is certainly that retail exerts a strong impact on the perception of food quality. We see a clear generational shift. While older consumers put considerable trust in wet markets and trust their own abilities to evaluate the quality of food more. Most likely, younger people are more aware of chemical contamination of food and rely more on the quality commitment of brands of food producers and mass retailers.

The generational shift is heading towards modern trade such as supermarkets. We also see, albeit on a much lower level, brands as more and more important trust agents. In contrast, quality certificates are on average not a substitute for the trust in retail and brands. Only a small segment of the market notices certificates and associates certificates with quality. At best, certificates are complementary, perceived as a modern element of food together with brands and supermarkets. In this sense they have a limited capacity to offset low trust in the food supply chain. Instead they strengthen and reinforce the perception of modernization of the food supply chain.



One of many food quality labels in Thailand

Consumer survey using conjoint measurement



3.11 Public Management Executive Development Program (PMED) 2010

Dr. Sununta Siengthai
School of Management

The PMED Program has been commissioned to AIT by the Ministry of Interior (with the Damrong Rajanupab Research and Development Institute as the co-host) since 2009. This is a capacity building program for the high-level personnel (i.e., Vice Governors or PC 9 and higher) of the Ministry. There are 3 main groups of subjects: (1) strategic management for competitive advantage of the nation, (2) natural resources, culture and tourism, and (3) agenda for good governance. The Program also requires the participants to conduct one practicum project to enhance their understanding and problem-solving skills.



In 2010, there were altogether 31 participants of which 5 participants reported on strategic management issues; 11 reported on natural resources management; and 15 reported on Agenda for good governance. Findings from the individual studies revealed that no matter which areas of issues the Vice Governors are faced with in terms of administrative dilemmas, the necessary conditions to achieve higher levels of effectiveness of provincial administrative goal performance included the following: (1) clear vision and mission with action plans aligned and key performance indicators to monitor the implementation process; (2) participative management; (3) social capital building; (4) developing the community or provincial society's readiness for change; (5) ensuring the integrated performance and developing teamwork of all parties concerned by the provincial governor; (6) the local government being strengthened.

3.12 The Impact of Total Quality Management on Supply Chain Management in Thai Automotive Industry

Dr. Barbara Igel
School of Management

The automotive industry in Thailand continues to grow at a fast pace. Thailand has the biggest automobile assembly base in the region. Due to this fact Thailand is known as “the Detroit of Asia”. The automotive industry is vital for the Thai economy and hence there is need to continuously improve its process.

In this growing automotive sector of Thailand, Dr. Barbara Igel, Associate Professor and Dean of School of Management along with Dr. Assadej Vanichchinchai, PhD graduate of SOM, AIT, did a research to investigate the relationships among total quality management practices (TQMP), supply chain management practices (SCMP) and firm's supply performance (FSP). During research, based on an extensive literature review, measurement instruments for SCMP, TQMP and FSP were developed and verified by experts, pilot test and various statistical techniques to ensure reliability and validity in structural equation modeling



constructs. The hypothesized model was tested through a path analysis and qualitative case studies of two large first-tier automotive suppliers were conducted to obtain more in-depth information. The results showed the set of SCMP, TQMP and FSP measures are reliable and valid for Thailand's automotive industry. And TQMP not only has a direct and significant positive impact on SCMP and on FSP, but also has an indirect and significant positive impact on FSP through SCMP.

3.13 SEA-UEMA Project

Prof. A. T. M Nurul Amin, Dr. Ranjit Perera, Dr. Edsel Sajor, Dr. Vilas Nitivattanon, Dr. Nowarat Coowanitwong, Dr. Kyoko Kusakabe

The Southeast Asia Urban Environmental Management Applications (SEA-UEMA) Project was a signature partnership between AIT and the Canadian International Development Agency (CIDA). The CAN\$ 9.48 million CIDA-funded project lasted from 1 August 2003 – 31 August 2010 and implemented work in 8 countries in Southeast Asia. The project improved implementation and sharing of sound urban environmental management policies and practices in the three key urban environmental sub-sectors of water and sanitation, solid waste, and air pollution.

Key Results

Gender equality was one of the crosscutting themes of the project. During the period of 2003-2008, the project implemented activities under five components, namely: Graduate Education, Alumni Demonstration Project, UEM Sub-Sector Network and Professional Support Program, Joint Action Research, and Application of Research Results and Lessons Learned towards achieving 4 outcomes and 4 output results. During the extension period (2009-2010), the project implemented activities under four core areas, namely: Flagship Projects, Policy Advocacy, Learning Networks and Training, and Graduate Education toward achieving 2 outcomes and 5 output results. Gender equality remained as one of the cross-cutting themes.

In total, the SEA-UEMA Project implemented the following during the whole implementation period (2003-2010): thirty-one (31) Alumni Demonstration Projects; twenty-six (26) Joint Action Research; four (4) Policy Advocacy; five (5) Pilot Projects; and five (5) Flagship Projects. The project also established 7 Country Nodes in Cambodia, Indonesia, Lao PDR, Philippines, and southern Vietnam and northern and central parts of Vietnam. The project provided 110 scholarships in Southeast Asian countries for students to pursue, PhD, masters, diploma and certificate level programs at AIT. The project trained 1636 specialists, researchers, and practitioners in various professional training courses and gender trainings. The project established 352 partnerships with different partners from 8 countries during implementation of its activities.

A total of 849 UEM experts, researchers, city managers and practitioners became Regional UEM network members, and a total of 21 UEM policies were put in the action agenda of relevant government agencies. Gender equality was integrated into most activities of the SEA-UEMA Project including planning, implementation, evaluation, and reporting.

The project recorded lessons learned, unexpected results, problems and challenges experienced over the period of project implementation and how overcome those. All project results were disseminated through dissemination meetings, websites, e-blogs, and through the distribution of publications. The project published numerous publications including case studies, monographs, policy briefs and proceedings of meetings, conferences and policy dialogues and forums. The SEA-UEMA Project also implemented a sustainability strategy to sustain the project beyond the project tenure.

Through the implementation of the SEA-UEMA Project, AIT made a significant contribution to improving urban environments in Southeast Asia, and it remains committed to supporting environmental improvements in the region.

Chapter 4: SCHOOL OF ENGINEERING AND TECHNOLOGY

4.1.1 Mission

School of Engineering and Technology (SET) is the synergistic integration in November 2005 of the two former Schools, namely, the School of Civil Engineering (SCE) and the School of Advanced Technologies (SAT).

Historically, these two schools came into existence only in January 1993 when the Institute reorganized the need to reform its academic structure from smaller-sized units called “Divisions” to larger bodies named “Schools”.

The School of Civil Engineering (SCE) represents the legacy of AIT when it was established with a single field of study in Hydraulics Engineering. Subsequently, other civil engineering fields of study were launched to assist the recovery from the ravages of the Second World War. SCE emphasized on a learning process that combines theoretical problem-solving and real life application of engineering principles. Its research orientation was outward-looking, addressing the actual and anticipated needs of the built environment.

The School of Advanced Technologies (SAT) consisted of fields of study that were launched in response to the needs of the regional industrialization in the second and third decades of AIT's existence. The School was committed to being international, multidisciplinary centers of excellence in Information, Communications, Industrial Systems, and Space Technologies through education, research and outreach.

The new School of Engineering and Technology amalgamating the School of Civil Engineering (SCE) and the School of Advanced Technologies (SAT) will strive to create synergies between the activities of the two former schools to build up world-class multidisciplinary and cross-disciplinary education, research and outreach activities across the boundaries of traditional fields of knowledge. More

interdisciplinary programs shall be launched so faculty members can work effectively across the disciplinary walls. The new school will enhance its academic portfolio by emphatically injecting the “5I” features namely internationality, innovation, integration, information technology and industrial partnership.

In line with the mission of the Institute, the mission of the School of Engineering and Technology is:

To develop highly qualified engineers and technologists who play leading roles in promoting the region's industrial competitiveness in its integration into the global economy.

More information about the school can be accessed at the SET's homepage <http://www.set.ait.asia/>.

4.1.2 Thematic Groups, Fields of Study and Multidisciplinary Programs

CIVIL AND INFRASTRUCTURE ENGINEERING GROUP

Since the founding of AIT, its civil engineering fields have promoted modern methodologies, emerging technologies and innovative materials for the design and construction of safe and economical infrastructure in the region. The Civil and Infrastructure Engineering group includes the following fields of study:

- Construction, Engineering and Infrastructure Management (CEIM)
- Geotechnical and Geoenvironmental Engineering (GGE)
- Structural Engineering (StE)
- Transportation Engineering (TrE)
- Water Engineering and Management (WEM)

INDUSTRIAL SYSTEMS ENGINEERING GROUP

For several decades, AIT has served in the development of the region by equipping young engineers with the high-tech knowledge required to work in complex industrial environments. Since its inception, the Industrial Systems Engineering (ISE) thematic group at AIT has contributed to this mission by focusing on industrial competitiveness and innovation for sustainable growth in the region. The ISE group is comprised of the following fields of study:

- Industrial and Manufacturing Engineering (IME)
- Nanotechnology
- Mechatronics (Mec)
- Microelectronics and Embedded Systems (MES)

INFORMATION AND COMMUNICATIONS GROUP

Information and communications enable access, connections and sharing, in turn enable knowledge creation and economic opportunity. The fields in the Information and Communications group are:

- Computer Science (CS)
- Information Management (IM)
- Remote Sensing and Geographic Information Systems (RSGIS)
- Telecommunications (TC)

Interdisciplinary Programs

- Offshore Technology and Management (OTM)
- Information and Communications Technologies (ICT)
- Disaster Preparedness, Mitigation and Management (DPMM)
- Gender, Transportation and Development (GTD)

4.1.3 Strategic Research Areas

The School of Engineering and Technology has identified broad research areas related to the strengths of its faculty, its curriculum and its existing facilities that are the building blocks for education niches in engineering and advanced technologies.

The following lists the information about the specific focal areas grouped by Fields of Study

Computer Science and Information Management (CSIM)

Software Engineering and Development; Information and Knowledge Management

Industrial Systems Engineering (ISE)

Design and development of devices and sensors; Automation and control of machines; Product design and integration of machines and processes; Planning, operation, control and logistics of Industrial systems

Remote Sensing and Geographic Information Systems (RS&GIS)

Remote sensing (RS); Geographic information system (GIS); Global positioning system (GPS); Digital mapping technology; Digital photogrammetry

Telecommunications, Information and Communications Technologies (TC, ICT)

Mobile Communications; Teletraffic and Network Performance Analysis; Focal Area 3: Optical Networks

Advanced Infrastructure Development

- *Application of new approaches and concepts in the development of infrastructure including innovative project financing*
- *PPP/PFI, integrated project management*
- *Infrastructure asset and valuation management, and infrastructure safety and security*

Geotechnical and Geoenvironmental Engineering (GGE)

Sustainable geological exploitation for engineering activities; Design of safe

structures; Disaster mitigation and rehabilitation

Structural Engineering (StE)

Computational Mechanics, Earthquake Resistant Design, Experimentation Methods, Advanced Structural Materials.

Transportation Engineering (TrE)

Transportation Logistics; Highway Pavement; Road Safety

Water Engineering and Management (WEM)

Integrated Water Resources Management (IWRM); Water Related Disaster Management (WRDM)

4.1.4 Academic Outreach Centers

The School of Engineering and Technology has a wealth of innovative and untapped knowledge database from its master's and doctoral research activities. Many outreach and research centers are set up to transform the knowledge into industrial needs. These centers also serve to transfer the practical aspects and the society impacts of the knowledge and technology back to the class room.

ACECOMS: Asian Center for Engineering Computations and Software

The prime mission of ACECOMS with 29 satellite centers in 21 cities in Asia and other regions carries out research in engineering computations, develops computer software tools for engineering applications, and conducts training in the effective use of latest computing technology. Visit ACECOMS: <http://www.acecoms.ait.asia/>

ACSIG: Asian Center for Soil Improvement and Geosynthetic

ACSIG provides a strategic location for advanced technological education, researches and outreach activities on the application and effective utilization of ground improvement techniques. Visit ACSIG: <http://www.set.ait.asia/acsig/>

ACTS: Asian Center for Transportation Studies

ACTS activities include modules on intelligent transportation systems, traffic simulation, freight transport, urban road safety and road safety audit. Visit ACTS: <http://www.set.ait.asia/acts/>

Geoinformatics Center

Geoinformatics Center is dedicated to development and promotion of remote sensing research and activities in Asia-Pacific by sharing satellite data, research results and experiences with researchers in the region. Visit Geoinformatics Center <http://www.geoinfo.ait.asia/>

Habitech Center

Habitech activities include research and outreach activities such as training in production and construction, provision of services associated with projects implemented by various organizations, agencies or the private sector. Visit Habitech: <http://www.habitech-international.com/home.html>

International Ferrocement Information Center

IFIC coordinates the activities of the International Ferrocement Society (IFS) including publication of "Journal of Ferrocement", conducting continuing education courses and sponsored research projects in low-cost construction. Visit IFIC: <http://www.set.ait.asia/ific/>

Regional Network Office for Urban Safety

The Regional Network Office for Urban Safety (RNUS) is a collaborative center jointly operated by the AIT and the University of Tokyo for the promotion of urban safety engineering utilizing advanced engineering technologies including remote sensing and GIS. Visit RNUS: <http://www.set.ait.asia/rnus/>

Thailand Accident Research Center

The Thailand Accident Research Center is an offspring of MOTC's Road Safety Master Plan acknowledging the lack of information on accidents in Thailand and the need to establish TARC. TARC provides academic back up and a base for road safety research. Visit TARC: <http://www.tarc.ait.asia>
<http://www.tarc.or.th/>

AIT Center of Excellence in Nanotechnology

The Center of Excellence in Nanotechnology is jointly supported by Thailand's Nanotechnology Center (NANOTEC) and AIT, to cultivate and foster multidisciplinary activities including research and education in the applications of Nanotechnology in Developing World. Visit CoEN: <http://www.nano.ait.asia>

4.1.5 Governance

Dean

NITIN V AFZULPURKAR, BEng, Univ of Poona, India; PhD, Univ of Canterbury, New Zealand

Associate Professor [*Computer vision (pattern recognition and image processing); MEMS design, fabrication for electronic and bio medical applications; Soft computing algorithms for robotics and automation applications; Mechatronics applications for industrial use*]

Associate Deans

NOPPADOL PHIEN-WEJ, BEng, Chulalongkorn Univ, Thailand; MS, PhD, Illinois at Urbana-Champaign, USA.

Associate Professor [*Tunnelling and other underground excavations in rocks and soils; Slope stability and retaining structures; Landslides; Earth structures and dams; Pile foundations; Buried pipes and culverts*] [*Soft ground tunnelling; Underground excavations in rock; Deep excavations; Land subsidence from deep well pumping; Rock properties*]

R M A P RAJATHEVA, B.Sc. Hons. (Eng), Moratuwa Univ, Sri Lanka; M.Sc., Ph.D. (Electrical and Computer Eng), Univ of Manitoba, Canada.

Associate Professor [*Digital and Mobile Communications, Cooperative Diversity, Relay Systems, OFDMA Resource Allocation, Cognitive Radio: Detection/Estimation Techniques, Space Time Processing-MIMO Systems, Distributed Video Coding (DVC)*]

BONAVENTURA H W HADIKUSUMO, BEng, Univ of Diponegoro, Indonesia; MEng, AIT; PhD, Univ of Hong Kong.

Associate Professor [*Construction Information Technology; Construction Project Management; Construction Site Safety, Virtual Reality application in construction; Web-based project design and management; System Dynamic Simulation in Construction; Construction site safety*]

4.1.6 Grants and Sponsored Research Completed in 2010

ACECOMS: Asian Center for Engineering Computations and Software

Database Development for Piping Analysis Software

Duration: 01 Dec 09 -30 Jul 10
Project Investigator(s): Naveed Anwar
Sponsor: Computers & Structures Inc
Total Contracted Amount (THB): 340,000

Performance Based Design of Knightsbridge Building

Duration: 01 Mar 09 -31 Dec 10
Project Investigator(s): Naveed Anwar
Sponsor: Century Properties Inc Manila, Phillipines
Total Contracted Amount (THB): 1,530,000

Performance Based Evaluation of Serendra District 1

Duration: 01 Jan 10 -31 Dec 10
Project Investigator(s): Naveed Anwar, Pennung warnitchai
Sponsor: Serendra Inc

Total Contracted Amount (THB): 1,024,000

Structural Peer Review of Lights Residences Building

Duration: 01 Jun 10 -31 Dec 10
Project Investigator(s): Naveed Anwar
Sponsor: SM Investments Corporation
Total Contracted Amount (THB): 1,440,000

Geoinformatics Center

Capacity Building in Poverty Mapping in ASEAN

Duration: 01 Jan 07 -15 Dec 10
Project Investigator(s): Lal Samarakoon
Sponsor: ASEAN Foundation
Total Contracted Amount (THB): 9,519,545

Development Planning, Management & Governance

Duration: 01 Nov 09 -31 Aug 10
Project Investigator(s): Lal Samarakoon
Sponsor: Government of India
Total Contracted Amount (THB): 2,400,000

JAXA Capacity Building 2009 - 2010

Duration: 28 Aug 09 -31 Oct 10
Project Investigator(s): Lal Samarakoon
Sponsor: Japan Aerospace Exploration Agency
Total Contracted Amount (THB): 9,862,668

Training cum Study visit Program on Project Management for Hygiene Sanitation and water Supply

Duration: 01 Apr 09 -31 Mar 10
Project Investigator(s): Lal Samarakoon
Sponsor: DANIDA Bangladesh
Total Contracted Amount (THB): 828,750

4.1.7 On-going Grants and Sponsored Research in 2010

Building Energy Code

Duration: 01 Jan 01 - 31 Dec 11
Project Investigator(s): Worsak Kanok-Nukulchai
Sponsor: Dansk Energi Management A/S, Denmark
Total Contracted Amount (THB): 14,040,001

ACECOMS: Asian Center for Engineering Computations and Software

ACEE 2010 the 3rd Asia Conference on Earthquake Engineering

Duration: 01 Sep 10 - 31 Mar 11
Project Investigator(s): Naveed Anwar, Pennung Warnitchai
Sponsor: ASEP, AIT, TIT, EIT
Total Contracted Amount (THB): 1,500,000

Geoinformatics Center

Application of Microwave remote sensing (Professional development Training)

Duration: 01 Jul 10 - 28 Feb 11
Project Investigator(s): Lal Samarakoon
Sponsor: Surveyor Association of Malaysia, PEJUTA
Total Contracted Amount (THB): 320,000

Developing Land cover Data Products in Monsoon Asia over the Period 2004-07 through Integration of Landsat and Multi-Temporal ALOS/PALSAR Imagery

Duration: 01 Apr 09 - 31 Mar 11
Project Investigator(s): Manzul Hazarika
Sponsor: University of Oklahoma, USA
Total Contracted Amount (THB): 1,020,000

Forest Information Planning and Management in Lao PDR

Duration: 01 Jul 10 - 30 Apr 11
Project Investigator(s): Lal Samarakoon
Sponsor: Kokusai Kogo Co Ltd
Total Contracted Amount (THB): 736,000

JAXA Capacity Building 2010 - 2011

Duration: 01 Oct 10 - 31 Oct 11
Project Investigator(s): Lal Samarakoon
Sponsor: Japan Aerospace Exploration Agency
Total Contracted Amount (THB): 8,387,410

NOAA AVHRR and Terra/ Aqua MODIS

Duration: 01 Apr 07 - 31 Mar 11
Project Investigator(s): Lal Samarakoon
Sponsor: Vision Tech/Japan
Total Contracted Amount (THB): 783,000

Satellite Data utilization for disaster Risk reduction and response Training Seminar and Workshop for Capacity Building in ASEAN

Duration: 01 Feb 09 - 31 Mar 11
Project Investigator(s): Lal Samarakoon
Sponsor: ADRC
Total Contracted Amount (THB): 14,185,344

Training Programs in Poverty Mapping

Duration: 01 Oct 08 - 31 Oct 11
Project Investigator(s): Lal Samarakoon
Sponsor: Multi-donors
Total Contracted Amount (THB): 576,000

4.1.8 Publications

International Journal Articles with Impact factor

Litsomboon T., Pichai Nimityongskul, Naveed Anwar. Development of lightweight aggregate concrete containing pulverized fly ash and bottom ash. Key Engineering Materials, (400-402) 0-0, 2010.

Naveed Anwar, Qaasim M.. Parametric study of reinforced concrete column cross-section for strength and ductility. Key Engineering Materials, (400-402) 0-0, 2010.

4.2: SET – COMPUTER SCIENCE and INFORMATION MANAGEMENT FIELDS OF STUDY

4.2.1 Introduction

Computer Science Field of Study

This field of study focuses on world-class teaching and research into the foundations and applications of computing systems. The curriculum covers a broad range of topics in computer systems, theory, software engineering, information science, and applications. The faculty are particularly active in artificial intelligence, security, computer graphics, machine learning and data mining, robotics, computer vision and image processing, software engineering, networking, simulation, and information systems.



iNexus is an end-to-end competitive experience from concept design of a system of robots programmed to perform according to rules of the game played on a high precision technical Contest Area and to score a victory beating the competitors at an international level. Top three teams from every country will be identified via iNexus who will get an opportunity to compete in the World Challenge

The courses and research topics span the range from theory to practice. Students are encouraged to take courses and conduct research in areas related to computer science such as Information Management, Telecommunications, Information and Communication Technologies, Remote Sensing and Geographic Information Systems, Mechatronics, Microelectronics and Embedded Systems, Industrial Engineering, and other fields of study at the Institute.

Software Engineering Area of Study

In addition to the traditional Masters program in computer science, the Computer Science field of study also offers a Master's degree in computer science with specialization in software engineering. The Software Engineering Area of Specialization is specially designed to fill the Asia-Pacific region's need for highly-trained specialists in software development and the management of software development projects.

Students in this specialization are expected, in the course of their thesis or research study, to get involved in the construction of large software systems, in the context of ongoing research projects at AIT or in collaboration with industry.

Information Management Field of Study

The Information Management field of study at AIT aims to fulfill the growing need for information management skills in government and private organizations. It was the first program of its kind in Asia.

The field focuses on planning the effective use of information and communication technologies within organizations, developing corporate and government policies to

maximize the benefits resulting from the wide-spread use of these technologies, improving the strategic management of information resources in business, government, and non-profit organizations, and increasing the productivity and creativity of managers and executives who work with information resources.

4.2.2 Research Facilities and Laboratories

CSIM laboratories are well-equipped for teaching and research. The program maintains its own file, Web, email, and database servers for experimental and daily use. The teaching lab is kept up to date with modern desktop systems and can seat up to 60 students for practical sessions. Specialized equipment includes a 20-core Xeon grid computing cluster, a heterogeneous compute cloud, an experimental broadband satellite link to Japan and other countries in the region, video and image processing equipment, and augmented/virtual reality equipment. Full wireless coverage in the building allows students to conveniently work with their personal notebook computers.

4.2.3 Faculty and Research Staff

Full-time Faculty

KANCHANA KANCHANASUT, PhD, MSc, Computer Science, University of Melbourne, Australia; Graduate Diploma, Computer Science, BSc Mathematics, University of Queensland, Australia.

Chair Professor, Thai Network Information Center (THNIC) and IntERLab Director (*Networking and Distributed Computing, Algorithms, Programming Languages*)

PETER HADDAWY, BA, Pomona College, Claremont, USA; MSc, PhD, Univ of Illinois, Urbana, USA.

Professor and Vice President for Academic Affairs (*until 30 June 2010*) (*Decision-Theoretic Problem Solving, Probabilities Reasoning, Modeling of User Preferences, Electronic Commerce, Medical Decision Making*)

PHAN MINH DUNG, MSc, PhD, University of Technology, Dresden, Germany.

Professor (*Computer and Network Security, Autonomous Computing, Logic Programming, Artificial Intelligence*)

VILAS WUWONGSE, DEng Systems Science, MEng Control Engineering, BEng Control Engineering, Tokyo Institute of Engineering, Japan.

Professor (*Information Representation, Semantic Web, Digital Libraries*)

SUMANTA GUHA, MS, PhD, University of Michigan, Ann Arbor, USA; PhD, Indian Statistical Institute, Calcutta, India; BSc, MSc, University of Calcutta, India.

Associate Professor (*Algorithms, Computer Graphics, Computational Geometry, Robotics*)

VATCHARAPORN ESICHAIKUL, BA, Chulalongkorn Univ, Thailand; MBA, Oklahoma State Univ; PhD, Kent State Univ, USA.

Associate Professor (*Electronic Commerce/Electronic Business, Web-based Information Systems, Hypermedia, Electronic Government*)

MATTHEW N. DAILEY, BSc, MSc, North Carolina State University, PhD, University of California, San Diego.

Assistant Professor (*Machine Vision & Learning, Robotics, Software Engineering and Open-source Software Development*)

PAUL JANECEK, BSEE, US Military Academy; MSc, Univ of London, UK; PhD, Swiss Federal Inst of Tech, Switzerland.

Assistant Professor (*Human-Computer Interaction; Analysis and Design of Information Visualization Systems, Semantic Fisheye Views, Software Engineering and Open-source Software Development, and Information System Development*)

Visiting and Adjunct Faculty

RAPHAEL DUBOZ, MA, Univ of Marseille, France; MA, Univ of Paris 6, France; PhD, Univ of Littoral Cote d'Opale, France.

Visiting Assistant Professor (*Computer Modeling and Simulation, with Applications in the Environment Science*)

KIM H W JOON, BSc, MSc, DSc, Dankook Graduate School, Korea.

Visiting Assistant Professor and Assistant Professor, Rangsit University (*Bounded Variation & its Application, Fuzzy Integral, Fuzzy System & Type-2 Fuzzy Set, Discrete Math*)

FINN ARVE AAGESEN, MSc, PhD, Norwegian Institute of Technology, Norway.

Adjunct Professor and Professor in NTNU (*Telematics Systems, Telecommunication Information Networking Architecture, Services & Resource Management, Communication Services & Networks*)

CHUTIPORN ANUTARIYA, BSc, Chulalongkorn University, MSc, DTech Sc, Asian Institute of Technology, Thailand.

Adjunct Faculty and Assistant Professor in Shinawatra Univ. (*Knowledge Representation, Intelligent Information Systems, Semantic Technologies, XML & Web Service Technologies*)

Research Staff

PHAN MINH THANG, BEng, Kaldol Kalman College, Hungary, MEng, Computer Science, Asian Institute of Technology, Thailand.

Researcher (*Argumentation*)

4.2.4 Grants and Sponsored Research Completed in 2010

Improvement of Logistics and Planning for Fashion Merchandise

Duration: 01 Jun 07 -28 Feb 10
Project Investigator(s): Paul Janecek
Sponsor: RTG and BTNC Company
Total Contracted Amount (THB): 1,500,000

iNexus Thailand Robotics Competition

Duration: 01 Dec 09 -31 Dec 10
Project Investigator(s): Matthew Dailey
Sponsor: Western Digital Co. Ltd.,NECTEC
Total Contracted Amount (THB): 350,000

Intelligent In Vehicle Driver Awareness Detection System

Duration: 01 Aug 10 -31 Oct 10
Project Investigator(s): Matthew Dailey
Sponsor: NECTEC, Thailand
Total Contracted Amount (THB): 200,000

Suspicious Target Tracking Robot

Duration: 01 Aug 09 -31 Dec 10
Project Investigator(s): Matthew N Dailey
Sponsor: RTG
Total Contracted Amount (THB): 900,000

Vision-Based Industrial Robotic Bin-Picking System (Phase III)

Duration: 01 Nov 09 -31 Jan 10
Project Investigator(s): Matthew Dailey
Sponsor: Solimac Co, Ltd
Total Contracted Amount (THB): 183,750

4.2.5 On-going Grants and Sponsored Research

A Ubiquitous computing architecture, for factory Automation, Control and Traceability

Duration: 01 Oct 09 - 01 Mar 11
Project Investigator(s): Paul Janecek
Sponsor: RTG/LIKITOMI
Total Contracted Amount (THB): 2,000,000

Creating blue print for Science, Mathematics and Technology Learning Center

Duration: 01 Sep 10 - 28 Feb 11
 Project Investigator(s): Vilas Wuwongse
 Sponsor: Institute of Promotion of Teaching Science and Technology (IPST)
 Total Contracted Amount (THB): 750,000

GMSARN Best Practice Project

Duration: 01 Jan 10 - 31 Dec 11
 Project Investigator(s): Vilas Wuwongse
 Sponsor: RTG
 Total Contracted Amount (THB): 2,800,000

Top 20 RTG- Asian University Research Ranking

Duration: 01 Sep 09 - 31 Aug 11
 Project Investigator(s): Peter F Haddawy
 Sponsor: RTG
 Total Contracted Amount (THB): 949,000

Vision-Based Industrial Robotic Bin-Picking System (PhaseIV)

Duration: 01 Feb 10 - 31 Jan 11
 Project Investigator(s): Matthew Dailey
 Sponsor: Solimac Co, Ltd
 Total Contracted Amount (THB): 880,000

4.2.6 Publications

Book

S. Guha, Computer Graphics Through OpenGL: From Theory to Experiments, Taylor & Francis: CRC/Chapman Hall, published September 2010.

International Journal Articles with Impact factor

Dailey, M.N., Joyce, C., Lyons, M.J., Kamachi, M., Ishi, H., Gyoba, J., and Cottrell, G.W. Evidence and a computational explanation of cultural differences in facial expression recognition. *Emotion*, 10(6) 874-893, 2010.

Hajime Tazaki, Rodney Van Meter, Ryuji Wakikawa, Thirapon Wongsardsakul, Kanchana Kanchanasut, Marcelo Dias de AMorin, Jun Murai: MANEMO Routing in Practice: Protocol Selection, Expected Performance, and Experimental Evaluation. *IEICE Transactions on Communications* 8 2004-2011, 2010.

P. Haddawy and S. Suebnukarn. Intelligent clinical training systems. *Methods of Information in Medicine*, Issue 4, pp 388-389, 2010.

Rhienmora P., Peter Haddawy, Khanal P., Siriwan Suebnukarn, Matthew Dailey. A virtual reality simulator for teaching and evaluating dental procedures. *Methods of Information in Medicine*, 4(49) 396-405, 2010.

S. Suebnukarn, P. Haddawy, P. Rhienmora, P. Jittimane, P. Viratket. Augmented kinematic feedback from haptic virtual reality for dental skill acquisition. *Journal of Dental Education*, 74(12), 1357-1366, 2010.

Siriwan Suebnukarn, Peter Haddawy, Rhienmora P., Gajananan K.. Haptic Virtual Reality for Skill Acquisition in Endodontics. *Journal of Endodontics*, 1(36) 53-55, 2010.

Sopharak A., Matthew Dailey, Uyyanonvara B., Barman S., Williamson T.. Machine learning approach to automatic exudate detection in retinal images from diabetic patients. *Journal of Modern Optics*, 2(57) 124-135, 2010.

Ungrangsi R., Chutiporn Anutariya, Vilas Wuwongse. Enhancing Folksonomy-Based Content Retrieval with Semantic Web Technology. *Semantic Web and Information Systems*, 6(1) 19-38, 2010.

Ziauddin S., Matthew Dailey. Robust iris verification for key management. *Pattern Recognition Letters*, 9(31) 926-935, 2010.

Journal Article/Book Chapter

Abbasi A.R., Matthew Dailey, Nitin V. Afzulpurkar, Uno T.. Student mental state inference from unintentional body gestures using dynamic Bayesian networks. *Journal on Multimodal User Interfaces*, 1(3) 21-31, 2010.

Esichaikul, V. and C. Bechter. "Catering for Different Learning Styles in e-Learning", *Learning and Instruction in the Digital Age*, Springer, 2010.

Esichaikul, V. and C. Suriyalert. "Site Selection Support Technologies for Convenience Stores", *Journal of Global Management Research*, 6(1) 19-36, 2010.

Esichaikul, V. and P. Srithongnopawong, "Using relative movement to support ANN-based stock forecasting in Thai stock market", *International Journal of Electronic Finance (IJEF)*, 4(1), 84-98, 2010.

Phan Minh Dung, Phan Minh Thang, Nguyen Duy Hung, "Modular Argumentation for Modelling Legal Doctrines of Performance Relief", *Argument & Computation*, 1(1) 47-69, Taylor & Francis, March 2010.

Samphaiboon, N. and Dailey, M.N. Steganography in Thai text. *International Journal of Digital Crime and Forensics*, 2(3) 43-64, 2010.

Conference Publications

Ahmed, M.T., Dailey, M.N., Landabaso, J.L., and Herrero, N. Robust key frame extraction for 3D reconstruction from video streams. In *International Conference on Computer Vision Theory and Applications (VISAPP)*, pages 231-236, 2010.

Ali, I. and Dailey, M.N. Head plane estimation improves the accuracy of pedestrian tracking in dense crowds. In *Proceedings of the International Conference on Automation, Robotics, and Computer Vision*, 2054-2059, 2010.

Bukhari, F. and Dailey, M.N. Robust radial distortion from a single image. In *International Symposium on Visual Computation, Lecture Notes in Computer Science vol. 6454*, pages 11-20, 2010.

Chaiprasert, C. and V. Esichaikul (2010). "Mobile Technology to Solve Motivation Problem in e-Learning System", *Proceedings of Global Learn Asia Pacific 2010 – Global Conference on Learning and Technology*, Penang, Malaysia, pages 168-173, May 17-20, 2010.

Chaivivatrakul, S., Moonrinta, J., and Dailey, M.N. Towards automated crop yield estimation: Detection and 3D reconstruction of pineapples in video sequences. In *International Conference on Computer Vision Theory and Applications (VISAPP)*, pages 180-183, 2010.

Chamnongsri N., Manmart L., Vilas Wuwongse. A study of users' requirements in the development of palm leaf manuscripts metadata schema, *International Conference on Asia-Pacific Digital Libraries (ICADL)*, Lecture Notes in Computer Science vol. 6102, pages 120-129.

Charoenchaimonkon, Eakachai, Janecek, P., Dailey, M.N., and Suchato, Atiwong. A comparison of audio and tactile displays for non-visual target selection tasks. In *International Conference on User Science and Engineering*, pages 238-243, 2010.

Erawan, T., D. Krairit and V. Esichaikul (2010). "Development of tourist information search behavior model: The case of Thailand", *Proceedings of PICMET 2010 Conference on Technology Management for Global Economic Growth*, Phuket, Thailand, pages 2930-2936, July 18-22, 2010.

Esichaikul, V., S. Guha and T. Niyamosatha (2010). "Mining Email Transaction Logs to Locate Significant Messages and Users", *IEEE Proceedings of ICMIA 2010*, Seoul, Korea, 30 November-2 December, 2010.

H. Kazi, P. Haddawy, S. Suebnukarn. Leveraging a Domain Ontology to Increase Quality of Feedback in an

Intelligent Tutoring System. In *Proceedings of the 10th International Conference on Intelligent Tutoring Systems*, Lecture Notes in Computer Science, vol 6094, pages 75-84, 2010.

Iqbal, W., Dailey, M.N., Ali, I., Janecek, P., and Carrera, D. Adaptive resource allocation for back-end mashup applications on a heterogeneous private cloud. In *Proceedings of ECTI-CON*, pages 317-321, 2010.

Iqbal W., Matthew N. Dailey, Carrera D., Paul Janecek. SLA-driven automatic bottleneck detection and resolution for read intensive multi-tier applications hosted on a cloud. *International Conference on Grid and Pervasive Computing (GPC)*, Lecture Notes in Computer Science vol. 6104, pages 37-46, 2010.

Krissada Maleewong, Chutiporn Anutariya, Vilas Wuwongse: Is Vote Effective? An Empirical Study of Community Deliberation in Social Webs. *WISE Workshops*, pages 171-183, 2010.

Krissada Maleewong, Chutiporn Anutariya, Vilas Wuwongse: Analyzing Community Deliberation and Achieving Consensual Knowledge in SAM. *IJOI* 1(3): pages 34-53, 2010.

Moonrinta, J., Chaivivatrakul, S., Dailey, M.N., and Ekpanyapong, M. Fruit detection, tracking, and 3D reconstruction for crop mapping and yield estimation. In *Proceedings of the International Conference on Automation, Robotics, and Computer Vision*, 2010.

Ouivirach, O. and Dailey, M.N. Clustering human behaviors with dynamic time warping and hidden Markov models for a video surveillance system. In *Proceedings of ECTI-CON*, pages 884-888, 2010.

Phan Minh Dung, Francesca Toni, Paolo Mancarella: Some design guidelines for practical

argumentation system, *Proceedings of COMMA 2010, Third International Conference on Computational Models of Argument*, Desenzano del Garda, Italy, 8-10 September, IOS Press Amsterdam, 2010.

Phan Minh Dung, Phan Minh Thang. Towards Probabilistic Argumentation for Jury-based Dispute Resolution. *Proceedings of COMMA 2010, Third International Conference on Computational Models of Argument*, Desenzano del Garda, Italy, 8-10 September, IOS Press Amsterdam, 2010.

Phan Minh Dung, Sartor G.. A logical model of private international law. *International Conference on Deontic Logic in Computer Science (DEON)*, Lecture Notes in Computer Science vol. 6181, pages 229-246, 2010.

Rehman, M. and V. Esichaikul, Factors for the Adoption of e-Government Services, *Proceedings of the 10th European Conference on e-Government*, Ireland, pages 567-574, June 17-18, 2010.

Rhienmora, P., Gajananan, K., Haddawy, P., Suebnukarn, S., Dailey, M.N., Supataratarn, E., and Shrestha, P. Haptic augmented reality dental trainer with automatic performance assessment. In *International Conference on Intelligent User Interfaces*, pages 425-426, 2010.

S. M. Doudpota, S. Guha, "Automatic Analysis of Movies for Content Characterization," *Proc. 2010 International Conference on Database and Data Mining (ICDDM 2010)*, Manila, Philippines, pages 465-469, 2010.

Sivaraks, P., D. Krairit and V. Esichaikul (2010). "Measuring E-CRM implementation and outcomes from the customers' perspectives", *Proceedings of PICMET 2010 Conference on Technology Management for Global Economic Growth*, Phuket, Thailand, pages 2950-2959, July 18-22, 2010.

Smutkupt, P., D. Krairit and V. Esichaikul (2010). "An empirical study of the effects of permission on mobile advertising effectiveness", *Proceedings of PICMET 2010 Conference on Technology Management for Global Economic Growth*, Phuket, Thailand, pages 2338-2345, July 18-22, 2010.

V. Esichaikul, S. Guha, T. Niyamosatha, "Mining Email Transaction Logs to Locate Significant Messages and Users", *Proc. 2nd International Conference on Data Mining and Intelligent Information Technology Applications (ICMIA 2010)*, Seoul, Korea, pages 368-371, 2010,.

Other Activities

Prof Phan Minh Dung, Associate Editor of Artificial Intelligence Journal (AIJ), http://www.elsevier.com/wps/find/journaleditorialboard.cws_home/505601/editorialboard. The AI Journal is the premier and most respected journal in the field of AI.

4.2.7 Doctoral Students' Dissertation

Computer Science

Clearing Outdated Information in Stabilizing Systems of Cooperative Communications Information Agents
By Do Duc Hanh
Supervisor: Prof. Phan Minh Dung

Efficient User Mobility Profile Strategies for Location Management in IP-based Cellular Networks
By Chansophea Chuon
Supervisor: Dr. Sumanta Guha

Employing the UMLS as Ontology to Achieve Robust Reasoning in an Intelligent Tutoring System for Medical Problem-Based Learning
By Hameedullah Kazi
Supervisors: Dr. Paul Janecek / Prof. Peter Haddawy

P2P SIP over Mobile Ad Hoc Networks
By Thirapon Wongsardsakul
Supervisor: Prof. Kanchana Kanchanasut

Practical Embedding Stegosystems with Security Proofs
By Natthawut Samphaiboon
Supervisor: Dr. Matthew Dailey

Secure Use of Biometric Data in Cryptographic Applications
By Zia Uddin
Supervisor: Dr. Matthew Dailey

4.2.8 Masters Students' Theses and Research Studies

Computer Science

3D Modeling of an Agricultural Field Inspection Robot
By Jednipat Moonrinta
Supervisor: Dr. Matthew Dailey

Argumentation-Based Advertisement Generation
By Songphon Klabwong
Supervisor: Prof. Phan Minh Dung

Comparative Analysis of Software Architectural Patterns for Mobile Ad Hoc Network Visualization Applications
By Munkhsambu Badrakh
Supervisor: Prof. Kanchana Kanchanasut

Linked Open Foreign Trade Data
By Hendrik
Supervisor: Prof. Vilas Wuwongse

Multiple Person Tracking and Left Luggage Detection Using Appearance Models
By Shashi Gharti
Supervisor: Dr. Matthew Dailey

Objective Outcome Scoring in a Dental Surgical Simulator
By Ekarin Supataratarn
Supervisor: Prof. Peter Haddawy

Parallel Perspective KD-Tree Construction on GPU
By Panasan Puapermpoonsiri
Supervisor: Dr. Sumanta Guha

Subject Area Representative Keywords Identification
By Pratikshya Kuinkel
Supervisor: Prof. Peter Haddawy

Research Study: Arbitrary Object Tracking Through Histogram Matching
By Abdul Basit
Supervisor: Dr. Matthew Dailey

Research Study: SMS Voice Dictation
By Nichjira Chobtum
Supervisor: Dr. Sumanta Guha

Research Study: Text Encapsulation: Summarization to the Minimum
By Imran Ali
Supervisor: Dr. Sumanta Guha

Information Management

Data Mining Using the Correlation between Pictures and Sounds
By Nathapong Bumrungsawat
Supervisor: Dr. Sumanta Guha

Legally Inspired Online Support for Dispute Resolution
By Tran Nguyen Duong Chi
Supervisor: Prof. Phan Minh Dung

Mobile Application to Monitor and Control Epidemic in Patients with Acute Respiratory Diseases (ARDs)
By Ratchadaporn Rermlawan
Supervisor: Dr. Vatcharaporn Esichaikul

Privacy and Access Control in Online Social Networks
By Rajiya Rijal
Supervisor: Prof. Phan Minh Dung

Recognizing Users Activity from an Accelerometer Sensor
By Chanaphan Prasomwong
Supervisor: Dr. Paul Janecek

Research Study: A Comparison of Cognitive Walkthrough and Heuristic Techniques for Formative Evaluation
By Thura Than
Supervisor: Dr. Paul Janecek

Research Study: A Hybrid Modeling Approach for Demand Forecasting: A Case Study of Raw Material Forecasting in the Restaurant Chain Business
By Thirut Supawongvisarn

Supervisor: Dr. Vatcharaporn Esichaikul

Research Study: Auditory Displays of Data for Vehicle Operators: Design and Evaluation for a Factory Environment

By Patipol Treerojporn

Supervisor: Dr. Paul Janecek

Research Study: Determining Significant Messages and Users Using Multi-Digraph in Enron Dataset

By Thanittha Niyamosatha

Supervisor: Dr. Sumanta Guha

Research Study: Ensemble Techniques to Predict the Consumer Rating of Movies

By Suresh Raj Bhattarai

Supervisor: Dr. Sumanta Guha

Research Study: Multi-Criteria Decision Making to Evaluate the Avian Influenza Control Strategies in Thailand

By Laorom Chiempiriyakul

Supervisor: Dr. Vatcharaporn Esichaikul

4.3: SET – CONSTRUCTION ENGINEERING AND INFRASTRUCTURE MANAGEMENT FIELD OF STUDY

4.3.1 Introduction

The Construction, Engineering and Infrastructure Management field trains professionals to play leading roles in the international construction industry and in infrastructure development and management. It offers courses in four levels - operations, project, strategic issues and corporate issues. It prepares students to become effective managers and decision-makers familiar with modern techniques of construction management, engineering management and infrastructure management.

The field's courses are delivered based on a hierarchical knowledge scale that considers principles and fundamentals, applications (tools and techniques), and emerging issues. In offering courses spanning fundamentals to advanced, the emphasis is on shifting from classical to innovative knowledge.

4.3.2 Faculty and Research Staff

CHOTCHAI CHAROENNGAM, BEng, King Mongkut's Inst of Tech, Thonburi, Thailand; MS, Univ of Kansas; PhD, Univ of Texas at Austin, USA

Associate Professor (*Project Planning, Scheduling, and Controls; Construction Productivity Improvement; Public Private Partnership Project; Project Financing*)

BONAVENTURA H W HADIKUSUMO, BEng, Univ of Diponegoro, Indonesia; MEng, AIT; PhD, Univ of Hong Kong.

Associate Professor (*Construction Information Technology; Construction Project Management; Construction Site Safety, Virtual Reality application in construction;*

Web-based project design and management; System Dynamic Simulation in Construction; Construction site safety)

4.3.3 Grants and Sponsored Research Completed in 2010

Advanced techniques for Budgeting of Capital Investment Projects (Phase II)

Duration: 01 Aug 09 -31 Mar 10
Project Investigator(s): Chotchai charoenngam
Sponsor: Chulalongkorn University
Total Contracted Amount (THB): 300,000

Advanced Techniques for Public Project financing

Duration: 01 Apr 10 -31 Dec 10
Project Investigator(s): Chotchai Charoenngam
Sponsor: Chulalongkorn University
Total Contracted Amount (THB): 300,000

Professional Master in Project Management Hanoi Sep 2009

Duration: 01 Sep 09 - 31 Dec 10
Project Investigator(s): BHW Hadikusumo, Chotchai Charoenngam
Sponsor: Construction Corporations in Vietnam
Total Contracted Amount (THB): 5,147,600

Professional Master in Project Management Ho Chi Minh City Class A Sep 2009

Duration: 01 Sep 10 - 31 Dec 10
Project Investigator(s): BHW Hadikusumo, Chotchai Charoenngam
Sponsor: Construction Corporations in Vietnam
Total Contracted Amount (THB): 8,137,628

Professional Master in Project Management Ho Chi Minh City Class B Sep 2009

Duration: 01 Sep 10 - 31 Dec 10
Project Investigator(s): BHW Hadikusumo, Chotchai Charoenngam
Sponsor: Construction Corporations in Vietnam
Total Contracted Amount (THB): 9,013,400

4.3.4 On-going Grants and Sponsored Research

Professional Master in Project Management Can Tho City 2010

Duration: 01 May 10 - 31 Dec 11
Project Investigator(s): BHW Hadikusumo, Chotchai Charoenngam
Sponsor: Construction Corporations in Vietnam
Total Contracted Amount (THB): 6,142,608

Professional Master in Project Management Hanoi Sep 2010

Duration: 01 Sep 10 - 31 Dec 11
Project Investigator(s): BHW Hadikusumo, Chotchai Charoenngam
Sponsor: Construction Corporations in Vietnam
Total Contracted Amount (THB): 5,105,310

Professional Master in Project Management Ho Chi Minh City Class A Sep 2010

Duration: 01 Sep 10 - 31 Dec 11
Project Investigator(s): BHW Hadikusumo, Chotchai Charoenngam
Sponsor: Construction Corporations in Vietnam
Total Contracted Amount (THB): 7,684,377

Professional Master in Project Management Ho Chi Minh City Class B Sep 2010

Duration: 01 Sep 10 - 31 Dec 11
Project Investigator(s): BHW Hadikusumo, Chotchai Charoenngam
Sponsor: Construction Corporations in Vietnam
Total Contracted Amount (THB): 7,018,758

4.3.5 Publications

International Journal Articles with Impact factor

C. Charoenngam. and W. Mahavarakorn (2010). Collaborative Negotiation Behaviors in Thai Construction Projects. *Journal of Legal Affairs and Dispute Resolution in Engineering and Construction*, ASCE, Accepted Manuscript June 25, 2010.

Dey P.K., C. Charoenngam, S. O. Ogunlana, D. Kajornkiat, Multi-party risk management helps manage cement plant construction in Thailand. *International Journal of Services, Technology and Management*, 4(11) 0-0, 2010.

N. Suksuwan and B.H.W. Hadikusumo (2010) "Condition Rating System for Thailand Concrete Bridges" *Journal of Construction in Development Country*, pp. 1-27, Vol. 15 No. 1, ISSN1823-6499.

O. Kulchartchai and B.H.W. Hadikusumo (2010) "Exploratory Study of Obstacles in Safety Culture Development in the Construction Industry: A Grounded Theory Approach" *Journal of Construction in Development Country*, pp. 45-66, Vol. 15 No. 1, ISSN1823-6499.

Prasertrungruang T., B.H.W. Hadikusumo. Modeling the dynamics of heavy equipment management practices and downtime in large highway contractors. *Journal of Construction Engineering and Management*, 10(135) 0-0, 2010.

Prasertrungruang T., B.H.W. Hadikusumo. Study of factors influencing the efficient management and downtime consequences of highway construction equipment in thailand. *Journal of Construction Engineering and Management*, 1(135) 0-0, 2010.

S. Posayanant. and C. Charoenngam (2010). Prototype KPIs for Rural Infrastructure Development: The Practice of Sub-District Local Governments. *International Journal of Productivity and Performance Management*, 59 (8). pp. 717-733.

Wethyavivorn P., C. Charoenngam, Teerajetgul W.. Strategic assets driving organizational capabilities of thai construction firms. *Journal of Construction Engineering and Management*, 11(135) 0-0, 2010.

4.3.6 Doctoral Students' Dissertation

A Condition Rating System and Deterioration Prediction Model for Concrete Highway Bridges in Thailand

By Nukul Suksuwan
Supervisor: Dr. B. Harimurti W. Hadikusumo

Development of a Worker Engagement Measurement Tool (WEMT) for a Construction Safety Program

By Oulawan Kulchartchai
Supervisor: Dr. B. Harimurti W. Hadikusumo

Infrastructure Engineering

A Hybrid Stochastic/Mechanistic Model for Determining Bridge Condition Rating

By Rajwanlop Kumpoopong
Supervisor: Dr. Chotchai Charoenngam

4.3.7 Masters Students' Theses and Projects

Application of Information Flow into Resource Management for Administrative and Operational Management in Vietnam

By Bich Ngoc Nguyen Tran
Supervisor: Dr. Chotchai Charoenngam

Assessing Project Management in Myanmar Construction Companies

By Saw Sandar
Supervisor: Dr. Bonaventura H. W. Hadikusumo

Asset Management in Public and Public Private Partnership (PPP) Hydropower Stations in Nepal

By Raj Kumar Lakhe
Supervisor: Dr. Chotchai Charoenngam

Construction Litigation Analysis: A Case Study of Thai Supreme Court Cases

By Tanatat Wisetsurakarn
Supervisor: Dr. Chotchai Charoenngam

Cultural Dimensions and Behavior of Construction Engineers in Thailand Related to On-Site Management

By Adithep Roobleak
Supervisor: Dr. Chotchai Charoenngam

Current Practices of Public Private Partnership in Low-Income Housing Development in Vietnam

By Truong Ngoc Quy
Supervisor: Dr. Chotchai Charoenngam

Implementation Problems Causing Cost Overrun of World Bank-Supported Construction Projects: A Case Study in Afghanistan

By Mohammad Sharif
Supervisor: Dr. Bonaventura H. W. Hadikusumo

Improving Quality Assurance in Construction: A Case Study in Petromekong Corporation, Vietnam

By Duong Thanh Hai
Supervisor: Dr. Bonaventura H. W. Hadikusumo

Investigation of Change Order Management: A Case Study of Oil and Gas Projects

By Le Dang Thuc
Supervisor: Dr. Bonaventura H. W. Hadikusumo

Owner's Contract Administration for Project Time and Cost Control Strategy in Commercial Building Projects

By Nguyen Xuan Phong
Supervisor: Dr. Bonaventura H. W. Hadikusumo

Relationship Between Project Phases and Stock Performance: A Study in Stock Exchange of Thailand (SET)

By Tinn Withayawaragul
Supervisor: Dr. B. Harimurti W. Hadikusumo

Relationship Marketing in Thai SME Contractors: Case Study of Bangkok and Khonkaen SME Contractors

By Amnarch Pirmsinthavee
Supervisor: Dr. Chotchai Charoenngam

Risk Factors Affecting Business Diversification in a Real Estate Company

By Kittichai Kanjanakantika
Supervisor: Dr. Chotchai Charoenngam

Special Purpose Vehicle in Toll-Road Project Development: A Case Study on the National Highway in Vietnam

By Truong Thi Van Anh
Supervisor: Dr. Chotchai Charoenngam

Success Factors for Financial Sustainability of Toll Road Projects in China

By Truong Thi My Thanh
Supervisor: Dr. Chotchai Charoenngam

Supply Chain Management: A Case Study of Construction Companies in Vietnam

By Vuong Hai Khoa
Supervisor: Dr. B. Harimurti W. Hadikusumo

Web Application for Contractor Claim Analysis

By Aung Chan Thar
Supervisor: Dr. Bonaventura H. W. Hadikusumo

Project: A Critical Appraisal of Briefing Clients in the Construction Process: A Case Study of Residential Project

By Nguyen Chau Dieu An
Supervisor: Dr. B. Harimurti W. Hadikusumo

Project: A Development Infrastructure Program to Support the Van Don Economic Zone

By Pham Van Thanh
Supervisor: Dr. Chotchai Charoenngam

Project: A Feasibility Study of a Curtain Wall Testing Company in Hanoi

By Nguyen Duy Duc Thu
Supervisor: Dr. B. Harimurti W. Hadikusumo

Project: Application of Fidic Contract in a Bridge Project: The Case of Can Tho Bridge

By Nguyen Thu Trang
Supervisor: Dr. Chotchai Charoenngam

Project: Assessment of Risks on the Design Management Aspects in Luxury Hotel Development Projects: The Case of Le Meridien Saigon Hotel

By Tran Thi Thien Trang
Supervisor: Dr. Chotchai Charoenngam

Project: A Study on Risk of Delay in Power Plant Projects: The Case of Nhon Trach 1 Combined Cycle Power Plant Project, Dong Nai, Vietnam

By Nguyen Le Minh
Supervisor: Dr. Chotchai Charoenngam

Project: Claim Management and Analysis: Case Study of a High Rise Building Project

By Nguyen Duy Thien Giang
Supervisor: Dr. B. Harimurti W. Hadikusumo

Project: Communication Management in a Construction Project: A Case Study of the Tallest Tower in HCMC

By Du Thien Duc
Supervisor: Dr. B. Harimurti W. Hadikusumo

Project: Delay in Planning, Design and Construction: A Case Study of Residential Development Project in Ho Chi Minh City

By Nguyen Hung Cuong
Supervisor: Dr. Chotchai Charoenngam

Project: Design Management in a Design-Build Project Based on the Design Team of Contractor Perspective

By Nguyen Cao Bao Luat
Supervisor: Dr. Chotchai Charoenngam

Project: Effectiveness of Feasibility Study Analysis in an Apartment Building Project: A Case Study of a Two Towers-Twenty Six Storey Apartment Project in Ho Chi Minh City

By Truong Ngoc Dung
Supervisor: Dr. B. Harimurti W. Hadikusumo

Project: Effective Project Management of a Resettlement Project: A Case Study of Binh Khanh Development Project

By Le Minh Dang
Supervisor: Dr. Chotchai Charoenngam

Project: Environmental Impacts Assessment in Nam Ly Bridge - Ho Chi Minh City, Vietnam

By Trinh Thi Thu Ha
Supervisor: Dr. B. Harimurti W. Hadikusumo

Project: Financing a High -Rise Apartment Building in Vietnam: The Case of Song Nhue Building, Hanoi

By Pham Nhu Dung
Supervisor: Dr. Chotchai Charoenngam

Project: Integrated Project Management Assessment for a Development Property Project at the Capital Fund in Vietnam

By Nguyen Phan Hoa Binh
Supervisor: Dr. Chotchai Charoenngam

Project: Method and Effectiveness of a Feasibility Study for an Apartment Project: The Case of Carina Plaza Building

By Le Mien Thuy
Supervisor: Dr. B. Harimurti W. Hadikusumo

Project: Minimizing the Impact of Change Order to Project Costs

By Chona Salvatus Salvahan
Supervisor: Dr. B. Harimurti W. Hadikusumo

Project: Organizational Project Management Structure in a Real Estate Developer Company: The Case of Namlong Corporation

By Nguyen Duc Trong
Supervisor: Dr. B. Harimurti W. Hadikusumo

Project: Owner's Involvement in the Preliminary Stage of Real Estate Development: A Project Case Study in Vietnam

By Truong Thai Binh
Supervisor: Dr. Chotchai Charoenngam

Project: Owner's Organization Project Management Maturity: The Case of Petrolimex Saigon

By Le Quang Khanh
Supervisor: Dr. B. Harimurti W. Hadikusumo

Project: Owner's Project Control Strategy

By Nguyen Le Thuan
Supervisor: Dr. B. Harimurti W. Hadikusumo

Project: Owner's Project Life Cycle Approach: The Case of Rubber Plantation Project in a Vietnam Rubber Company

By Do Huu Phuoc
Supervisor: Dr. B. Harimurti W. Hadikusumo

Project: Owner's Project Schedule Management for High-Rise Office Building Projects: A Case Study of the Construction Project of Petrovietnam Finance Centre in Danang City

By Le Nam Binh
Supervisor: Dr. B. Harimurti W. Hadikusumo

Project: Planning to Improve the Efficiency of a Housing Project's Development Process: The Case of a High-Rise Mixed Use Development in Ho Chi Minh City, Vietnam

By Bui Quang Huy

Supervisor: Dr. B. Harimurti W. Hadikusumo

Project: Project Management Life Cycle and Risk Management in a New Residential Development Project in Vietnam: The Case Study of the Fifth Street New Residential Project (D2D's Company) and its Secondary Project (Berjaya-D@D Joint Venture Company)

By Tran Thanh Liem

Supervisor: Dr. B. Harimurti W. Hadikusumo

Project: Project Management Practice in a Small and Medium Vietnamese Contractor: The Case of Nhat Dang Company

By Vo Dinh Nguyen

Supervisor: Dr. Chotchai Charoenngam

Project: Project Organizational Structure Roles and Responsibility - The Case of Marriott Five-Star Hotel

By Tran Duc Quang

Supervisor: Dr. B. Harimurti W. Hadikusumo

Project: Project Owner's Quality Management System - The Case of Sails Tower Project

By Nguyen Trung Kien

Supervisor: Dr. B. Harimurti W. Hadikusumo

Project: Project Schedule Delay and Risks in a Rural Infrastructure Development Project: A Case Study of the Rehabilitation of a Calamity Damage in Vietnam

By Bui Duc Luong

Supervisor: Dr. B. Harimurti W. Hadikusumo

Project: Risk Management in a Low-Income Housing Project Development in Ho Chi Minh City

By Le Quoc Tuan

Supervisor: Dr. B. Harimurti W. Hadikusumo

Project: Risk Management in Price Adjustment Contract: A Case Study of a Construction Project in Vietnam

By Hoang Thi Hai Anh

Supervisor: Dr. B. Harimurti W. Hadikusumo

Project: Risk Management in the Design of Large-Scale Construction Projects: Case Studies of an Urban Area and a Highrise Building Project

By Do Tran My Thuy

Supervisor: Dr. Chotchai Charoenngam

Project: Risk Management in the PPP Expressway Project in Vietnam: A Case Study of Ha Noi - Hai Phong Expressway Project

By Vu Van Cao

Supervisor: Dr. Chotchai Charoenngam

Project: Risk Management of Basement Construction Affecting Adjacent Buildings: A Case Study of Construction Project in Ho Chi Minh City, Vietnam

By Dang Tuan Anh

Supervisor: Dr. B. Harimurti W. Hadikusumo

Project: Risks Affecting Construction Cost in Vietnam

By Le Ngoc Diep

Supervisor: Dr. B. Harimurti W. Hadikusumo

Project: Schedule Planning and Control in an Engineering, Procurement and Construction Project: The Case of a City Hall Project

By Vo Si Hoai

Supervisor: Dr. B. Harimurti W. Hadikusumo

Project Management in Construction

Project: Contractual Risks of SME Contractors - A Case Study of a Mechanical and Electrical Contractor

By Vo Quoc Vinh

Supervisor: Dr. B. Harimurti W. Hadikusumo

Project: Risk Factors in Vietnam Power Plant Projects: A Case Study of Nhon Trach Power Plant and Camau Gas Power Fertilise Projects

By Nguyen Duc Thanh

Supervisor: Dr. B. Harimurti W. Hadikusumo

Project: Risk Management in Pipeline Operation Management: A Case Study of Petrovietnam Gas Pipeline System

By Trieu Quoc Tuan

Supervisor: Dr. B. Harimurti W. Hadikusumo

Project: Subcontractor Management in an LPG Truck Loading Projects

By Vu Van Ngu

Supervisor: Dr. B. Harimurti W. Hadikusumo

Project: Subcontractor Management in Gas Projects: A Case Study of PVGAS Gas Distribution Centre Project

By Phan Thi Hai Giang

Supervisor: Dr. B. Harimurti W. Hadikusumo

Project: The Delay Factors in EPC Contracts in Vietnam: The Case of Uong Bi Thermal Power Plant

By Tran Van Trung

Supervisor: Dr. B. Harimurti W. Hadikusumo

4.4 SET – GEOTECHNICAL & EARTH RESOURCES ENGINEERING FIELD OF STUDY

4.4.1 Introduction

The Geotechnical and Geoenvironmental Engineering field of study consists of the following areas of specializations, i.e., Soil Engineering, Engineering and Applied Geology, Geoenvironmental Engineering and an interdisciplinary program of Geoexploration and Petroleum Geoengineering (GEPG). Besides the traditional areas of engineering geology and soil engineering such as foundation engineering, earth structures, underground excavations, land subsidence, and landslide mitigations, geotechnical engineers and researchers are increasingly involved in areas of ground improvement, geosynthetic engineering, land reclamation, lightweight materials and forensic geotechnical engineering. Furthermore, geotechnical engineers are increasingly challenged to solve environmental problems related to the reduction of construction wastes, provision of efficient waste disposal facilities, clean-up of contaminated sites as well as geological related hazards such as landslides and soil erosion. To meet the increasing demands of the region in finding new mineral and energy resources, since 2001 a new interdisciplinary area of specialization in Geosystem Exploration and Petroleum Geoengineering has been setup for development of human resources to serve the mining industry and especially the Exploration and Production (E & P) sector of the oil and gas industry. In accommodating these requirements, the courses in the field have been enhanced to equip geotechnical and exploration engineers not only with traditional knowledge of soil mechanics and geology but also with skills in hydrogeology, geochemistry, biological processes, petroleum engineering, engineering and exploration geophysics. Since 2008 the field had successfully opened and operated two professional programs in

Geoexploration & Petroleum Geoengineering (PME-GEPG) and Geotechnical Engineering & Management (PME-GEM), respectively, in HCM City to meet the increasing demands of Vietnam in these areas.

4.4.2 Research Facilities and Laboratories

The Geotechnical and Geoenvironmental Laboratory can be boasted as one of the most equipped geotechnical laboratories in the region with more than 30 years of experience in both soil and rock testing. The laboratory, which offer technical services on testing and research on the engineering behavior and properties of soil and rock; geologic mapping; environmental geophysical surveys; and testing of geosynthetic materials conducted by ACSIG, consists of five (5) sections - Soil Mechanics, Rock Mechanics, Engineering Geology, Geophysics, and Geoenvironmental Engineering.

Soil Mechanics Laboratory

The Soil Mechanics Laboratory has facilities for testing and research on the engineering behavior and fundamental properties of soil. It is equipped to test compaction, seepage, compressibility, deformation and shear strength, soil dynamics, and ground improvement.

Among other equipment, it has an automatic Central Data Acquisition System (CDAS) and two temperature-controlled rooms that house triaxial and consolidation equipment. Its field operation unit has a full range of tools for sampling soils and rocks and field test equipments for vane tests, Dutch cone tests, piezocone tests, pressuremeter tests, screw plate

tests, electric logging, and vibration measurements.

Rock Mechanics Laboratory

The Rock Mechanics Laboratory has facilities to determine a variety of the physical and mechanical properties of rocks and rock aggregates required for research and practice.

Moreover, the laboratory is capable of determining hardness, swelling and slake durability index properties of weak rocks. The laboratory has provided testing services to a large number of infrastructure projects in the region.

Engineering Geology Laboratory

The Engineering Geology Laboratory has facilities for research on the engineering behavior and fundamental properties of rocks and minerals.

It provides classification and characterization tests for rock and minerals including petrographic and X-ray diffraction studies. It has stereoscopes, radial line planimetric plotter, stereo-sketch and sketch masters for analysis and interpretation of airphotos as applied to mineral explorations, transportation route studies, forestry, and civil engineering.

Geophysics Laboratory

The Geophysics Laboratory is being developed for training and researches in Geosystem Exploration and Petroleum Geoengineering. It has a number of seismic, electric, magnetic and radiometric instruments, including some of the most advanced equipment such as DAS-1 (OYO), a multipurpose hi-

performance seismic data acquisition system, or SYSCAL R1 Plus (IRIS Instruments), an all-in-one multi-electrode resistivity and induced polarization (IP) imaging system.

The Laboratory is capable of conducting and assisting in geophysical field surveys for engineering, environmental, mineral resources, oil and gas exploration as well as in performing analysis, interpretation and visualization of geophysical data acquired.

Geoexploration and Petroleum Geoengeeing Laboratory

This new laboratory unit hosts high-capacity computers installed with very specialized software used in the upstream sector of petroleum E&P industry, notably with the well-known software for subsurface exploration, petrophysical characterization and reservoir simulation such as Petrel, Interactive Petrophysics, Eclipse etc. which are worth of more than 2 million USD as donated by Schlumberger to AIT.

Geoenvironmental Laboratory

The Geoenvironmental Laboratory provides a variety of equipment for geoenvironmental engineering research. It has equipment for geotechnical and chemical analysis that supports research in fundamental processes related to soil, water and chemical interactions that are applied to site and risk assessment, waste containment systems, and remedial technology. The chemical analysis equipment, spectrophotometer, from which the ion concentration can be determined with good accuracy and precision, enables research on soil-contaminant interaction.

Flexible wall permeameter, rigid wall permeameter and consolidation cell with permeameter are used to analyze water and chemical migration through waste containment systems. While the

electrokinetic cell with advanced monitoring and controlled system is utilized for research in site reclamation and site remediation.

4.4.3 Faculty and Research Staff

Emeritus Professor

A S BALASUBRAMANIAM, BSc, Ceylon Univ, Sri Lanka; PhD, Cambridge Univ, UK

Full-time Faculty

DENNES T BERGADO, BSCE, Mindanao State Univ, Philippines; MEng, AIT, Thailand; PhD, Utah State Univ, USA

Professor (*Ground improvement techniques and geosynthetics, In-situ testing, Geotechnical disaster mitigation, and Probabilistic/ numerical methods in geotechnical engineering*)

NOPPADOL PHIEN-WEJ, BEng, Chulalongkorn Univ, Thailand; MS, PhD, Illinois at Urbana-Champaign, USA.

Associate Professor (*Tunnelling and underground excavations in rocks and soils; Slope stability and retaining structures; Landslides; Earth structures and dams; Pile foundations; Buried pipes and culverts*)

KYUNG-HO PARK, BEng, MEng, Korea Univ; DEng, SUNY at Buffalo, USA.

Assistant Professor (*Geotechnical Engineering; Geomechanics; Computational Mechanics; Boundary Element Methods*)

PHAM HUY GIAO, DEng, MEng, Asian Institute of Technology, Thailand; Dipl Ing (MSc), Bucharest University, Romania

Assistant Professor (*Exploration and Engineering Geophysics; Petrophysics; Geotechnical*

Engineering; Computer-aided Analysis in Geoengineering)

4.4.4 Grants and Sponsored Research Completed in 2010

Building Human Resources in the Development of Academic Programs in Sustainable Geosystem Exploration and Engineering

Duration: 01 Nov 05 -30 Jun 10
Project Investigator(s): Pham Huy Giao and Noppadol Phien-wej
Sponsor: Asia Link / European Commission
Total Contracted Amount (THB): 4,674,126.00

Consolidation of Clay using PVD with vaccum preloading

Duration: 01 Aug 08 -31 May 10
Project Investigator(s): Dennes T. Bergado
Sponsor: Maruyama Industry Co.Ltd
Total Contracted Amount (THB): 1,400,000

Development of Software tool for frame analysis and design of high strength steel bolted beam column joints

Duration: 01 Nov 08 -01 Nov 10
Project Investigator(s): K H Park
Sponsor: RTG/SYS E & I
Total Contracted Amount (THB): 2,000,000

Engineering analysis for flood fences structure manangement at Pathumthani province

Duration: 12 Oct 08 -31 Oct 10
Project Investigator(s): Noppadol Phien-wej
Sponsor: RTG
Total Contracted Amount (THB): 900,000

Evaluation and Tests of Laterite soil stabilized with CHEM Road and Cement

Duration: 01 Nov 09 -16 Feb 10
Project Investigator(s): Dennes T. Bergado
Sponsor: Indochina Engineering Systems Company Ltd
Total Contracted Amount (THB): 300,300

Investigation and Analysis of River Bank retaining Structures in Aumphur Pamoke, Ang Thong Province

Duration: 01 Feb 10 -31 Dec 10
Project Investigator(s): Noppadol Phien-wej
Sponsor: LVC Development Company Ltd.
Total Contracted Amount (THB): 267,500

Investigation on Bank Slope Failure, Taluang Cement Factory

Duration: 01 Feb 10 -30 Oct 10
Project Investigator(s): Noppadol Phien-wej
Sponsor: Siam City Cement Public Co Ltd
Total Contracted Amount (THB): 1,412,400

Modified Limited Life Woven Geotextiles (LLG's) made of Natural fibers for soil erosion control and soil reinforcement

Duration: 03 Jul 09 -02 Jul 10
Project Investigator(s): Dennes T.Bergado
Sponsor: RTG
Total Contracted Amount (THB): 948,000

PM&E Program in Geoexploration and Petroleum Geoengineering, Batch II

Duration: 01 Sep 09 -31 Dec 10
Project Investigator(s): Pham Huy Giao
Sponsor: Oil and Gas Company, Vietnam
Total Contracted Amount (THB): 4,730,250

Professional Masters Program in Geotechnical Engineering and Management, Batch 01

Duration: 01 Feb 09 -30 May 10
Project Investigator(s): Pham Huy Giao, Noppadol Phien Wej, D Bergado
Sponsor: Professional Managers
Total Contracted Amount (THB): 4,338,985

Services on Design of Civil works of Prototype Underground unit substations

Duration: 15 Jan 09 -30 Dec 10
Project Investigator(s): Noppadol Phien-wej
Sponsor: Metropolitan Electricity Authority
Total Contracted Amount (THB): 1,850,000

4.4.5 On-going Grants and Sponsored Research

A Geoenvironmental-Geophysical Investigation of Petroleum – Contaminated soil at the Don Muang Airport site by using Electric imaging technique

Duration: 15 Jul 09 - 15 Jul 11
Project Investigator(s): Pham Huy Giao
Sponsor: RTG
Total Contracted Amount (THB): 990,000

Global Center of excellence on Human Security Engineering for Infrastructure Management of Kyoto University Phase1

Duration: 01 Jan 09 - 30 Jun 11
Project Investigator(s): Noppadol Phien-wej
Sponsor: University of Kyoto
Total Contracted Amount (THB): 2,754,662

Instrumentation Interpretation of Nam Ngum 2 CFRD

Duration: 01 Jan 10 - 30 Jul 11
Project Investigator(s): Noppadol Phien-wej
Sponsor: Ch Karnchang Lao Ltd
Total Contracted Amount (THB): 1,170,000

Investigation on Flooding at Tank terminal of MC Siam, Pra Pradaeng

Duration: 01 Jun 10 - 28 Feb 11
Project Investigator(s): Noppadol Phien-wej
Sponsor: OY Corporation Ltd
Total Contracted Amount (THB): 1,356,225

PME Program in Geoexploration and Petroleum Geoengineering Batch III

Duration: 01 Sep 10 - 30 May 12
Project Investigator(s): Pham Huy Giao, Noppadol Phien-Wej
Sponsor: Oil and Gas Company, Vietnam
Total Contracted Amount (THB): 3,850,143

Professional Masters Program in Geotechnical Engineering and Management, Batch II

Duration: 01 Sept 10 -30 May 12
Project Investigator(s): Pham Huy Giao, Noppadol Phien Wej, D Bergado
Sponsor: Professional Managers
Total Contracted Amount (THB): 3,848,650

RTG/Seismic safety of earth dam in Northern Thailand

Duration: 01 Jul 09 - 31 May 11
Project Investigator(s): K H Park
Sponsor: RTG
Total Contracted Amount (THB): 900,000

4.4.6 Publications

International Journal Articles with Impact factor

A Balasubramaniam, Oh E.Y.N., Phienwej N.. Bored and driven pile testing in Bangkok sub-soils. Lowland Technology International, 1(11) 0-0, 2010.

Giao P. H. and Panupong D. (2010), Determination of shale resistivity based on 2-D forward modeling for evaluation of a low resistivity formation, PetroVietnam Journal, 44-49, Vol. 10, 2010, ISBN-0866-854X.

Hien D. D. and P. H. Giao (2010), A Geotechnical-geophysical Study of the Red River Delta, Lambert Academic Publishing GmbH & Co. KG, Germany, ISBN 978-3-8433-8033-1, 153 p

Hue D. T. M., N. Phien-wej and P. H. Giao (2010), Evaluation of the Changes in Stiff Clay Microstructure

by SEM Digital Image Processing, Geotechnical Journal, Vietnam Geotechnical Society.

Arjnoi P., Jeong J.-H., Kim C.-Y., Kyung-Ho Park. Effect of drainage conditions on porewater pressure distributions and lining stresses in drained tunnels. Tunnelling and Underground Space Technology, 4(24) 0-0, 2010.

Kyung-Ho Park, Tantayopin K., Tontavanich B., Owatsiriwong A.. Analytical solution for seismic-induced ovaling of circular tunnel lining under no-slip interface conditions: A revisit. Tunnelling and Underground Space Technology, 2(24) 0-0, 2010.

Methacanon P., Weerawatsophon U., Sumransin N., Prahsarn C., Dennes T. Bergado. Properties and potential application of the selected natural fibers as limited life geotextiles. Carbohydrate Polymers, 4(82) 0-0, 2010.

Owatsiriwong A., Phansri B., Kong J.-S., Kyung-Ho Park. A cell-less BEM formulation for axisymmetric elastoplasticity via particular integrals. Computational Mechanics, 2(44) 0-0, 2010.

Phansri B., Kyung-Ho Park, Pennung Warnitchai. A BEM formulation for inelastic transient dynamic analysis using domain decomposition and particular integrals. Computational Mechanics, () 0-0, 2010.

Pothiraksanon C., Saowapakpi boon J., Dennes T. Bergado, Voottipruex P., Abuel-Naga H.M.. Soft ground improvement with solar-powered drainage. Proceedings of the Institution of Civil Engineers: Ground Improvement, 1(163) 0-0, 2010.

Pothiraksanon, C., Dennes T. Bergado, and Abuel-Naga, H.M. Full Scale Consolidation Test using Prefabricated Vertical Thermal Drains. Soils and Foundations, 50(5), 579-588, 2010.

Quang N. D., Giao P. H. & T. Seah (2010), Settlement Calculation and Back Analysis of Soil Properties for a Test Embankment on a Soft Clay Ground Improved by PVD and Vacuum-Assisted Preloading at a Site in Vung Tau, Geotechnical Journal, Vietnam Geotechnical Society.

Riyaz M., Kyung-Ho Park, Ali M., Kan H.. Influence of geological setting of islands and significance of reefs for tsunami wave impact on the Atoll Islands, Maldives. Bulletin of Engineering Geology and the Environment, 3(69) 0-0, 2010.

Riyaz M., Kyung-Ho Park. Safer Island Concept developed after the 2004 Indian Ocean Tsunami: A case study of maldives. Journal of Earthquake and Tsunami, 2(4) 0-0, 2010.

Saowapakpiboon J., Dennes T. Bergado, Voottipruex P., Lam L.G., Nakakuma K.. PVD improvement combined with surcharge and vacuum preloading including simulations. Geotextiles and Geomembranes, () 0-0, 2010.

Saowapakpiboon J., Dennes T. Bergado, Youwai S., Jin Chuan Chai, Wanthong P.. Measured and predicted performance of prefabricated vertical drains (PVDs) with and without vacuum preloading. Geotextiles and Geomembranes, 1(28) 0-0, 2010.

Tanchaisawat T., Dennes T. Bergado, Voottipruex P., Shehzad K.. Interaction between geogrid reinforcement and tire chip-sand lightweight backfill. Geotextiles and Geomembranes, 1(28) 0-0, 2010.

Tanchaisawat T., Dennes T. Bergado. Interaction between geogrid and tire chips-sand mixture: Pullout test simulation. Kasetsart Journal - Natural Science, 5(43) 0-0, 2010.

Trani, L.D.O., Dennes T. Bergado, Abuel-Naga, H.M., Thermo-mechanical Behavior of Normally Consolidated Soft Bangkok Clay.

International Journal of Geotechnical Engineering, 4(1), 31-44, 2010.

Tin, N., Dennes T. Bergado, Anderson, L.R., Voottipruex, P. Factors Affecting Kinked Steel Grids Reinforcement in MSE Structures. Geotextiles and Geomembranes, 29(2), 178-180, 2010.

Voottipruex P., Dennes T. Bergado, Tanchaisawat T.. Lightweight recycled geomaterials reinforced with geogrids. Proceedings of the Institution of Civil Engineers: Ground Improvement, 1(163) 0-0, 2010.

4.4.7 Masters Students' Theses, Research Studies and Internships

A Study on Hydrocarbon Potential and Exploration of Fang Basin, Thailand

By Nitchakan Senkhamwong
Supervisor: Dr. Pham Huy Giao

Basin Modeling and Geopressure Analysis for the Khorat Plateau, North Eastern Thailand

By Suwisa Koysamran
Supervisor: Dr. Pham Huy Giao

Electromagnetic Responses of Some Oil and Gas Basins in Southeast Asia using Model-Based Inversion

By Khin Moh Moh Latt
Supervisor: Dr. Pham Huy Giao

Evaluation of Low Resistivity Hydrocarbon Bearing Formation

By Panupong Dangyeunyong
Supervisor: Dr. Pham Huy Giao

Geological Modeling of a Reservoir in Natural Fractured Granite Basement

By Trung Cong Le
Supervisor: Dr. Pham Huy Giao

Groundwater Flow Modelling and Slope Stability Evaluation for Deepening of Mae Moh Open Pit Lignite Mine

By Anjula Buddhika Nayomi Dassanayake
Supervisor: Dr. Noppadol Phien-wej

Integrated Interpretation of Well Logging Data with Reference to Reservoir Characterization of Fang Oil Field

By Parkpum Amornrujiroj
Supervisor: Dr. Pham Huy Giao

Landslide Susceptibility Analysis Based on GIS and Remote Sensing (A Case Study in East Java Indonesia)

By Muhammad Qasim
Supervisors: Dr. Kyung-Ho Park / Dr. Manzul Kumar Hazarika

Numerical Simulation of PVD Preloading with and without Vacuum Pressure as well as Heat in the Laboratory and Field Conditions

By Wanittapon Wongprasam
Supervisor: Prof. Dennes T. Bergado

Numerical Simulation of Vertically Stacked Twin Tunnels in Bangkok Subway

By Patara Kalayasri
Supervisor: Dr. Kyung-Ho Park

Optimal Production Strategy for Water-Drive Gas Reservoirs

By Thanakorn Rattanawai
Supervisors: Dr. Pham Huy Giao / Dr. Suwat Athichanagorn

Piled Foundation Responses to Soft Ground Tunneling in Bangkok Subway

By Paverean Mudcharoen
Supervisor: Dr. Noppadol Phien-wej

Prediction of Water Inflow into Tunnel during Progressive Drilling

By Yar Kyaw Shein
Supervisor: Dr. Kyung-Ho Park

Processing of High Resolution Seismic Data for a Drilling Rig Site Survey in the Gulf of Thailand

By Supakorn Nunthakungwan
Supervisor: Dr. Pham Huy Giao

Soil-Water Characteristics and Permeability of Residual Soils in Northern Thailand Prone to Rain-Triggered Landslides

By Thanapon Wirojarust
Supervisor: Prof. Dennes T. Bergado

Professional Master in Geotechnical Engineering and Management

Research Study: A Numerical Analysis of Diaphragm Wall at the Thi Nghe Pumping Station

By Nguyen Tien Dat
Supervisor: Dr. Noppadol Phien-wej

Research Study: Application of Analytical Method and Field Observations for Soil Improvement by the Vacuum Combined Surcharge Preloading in SITV Project

By Nguyen Duy Quang
Supervisor: Dr. Pham Huy Giao / Dr. T. H. Seah

Research Study: Estimation of the Settlement by Plaxis and Comparing with the Observation Data of Soft Improvement by PVD with (and without) Vacuum for CMIT Project at Baria-Vungtau, Vietnam

By Pham Bich Ngoc
Supervisor: Prof. Dennes T. Bergado

Research Study: Geological Engineering Investigation of Ban Mong Reservoir Project, Quy Hop-Nghe An, Vietnam

By Le Hong Anh
Supervisor: Dr. Pham Huy Giao

Research Study: Ground Improvement by DMM at SP-PSA

Project in Thi Vai Riverside, Ba Ria - Vung Tau, Vietnam

By Vo Minh Thang
Supervisor: Prof. Dennes T. Bergado

Professional Master in Geo-Exploration and Petroleum Geoengineering

Research Study: Building the 3D Static Geological Model for the LM Reservoir, the Cuu Long Basin, Southern Vietnam

By Luu Minh Luong
Supervisor: Dr. Pham Huy Giao

Research Study: Determination of Porosity and Permeability of the Fractured Basement of Hai Su Den Structure Using the Multi-Mineral Method

By Nguyen Le Phuong
Supervisor: Dr. Pham Huy Giao

Research Study: Geological Modeling of a Fractured Basement Reservoir Using Integrated Well and Seismic Data

By Phan Thi Nguyet Minh
Supervisor: Dr. Pham Huy Giao

Research Study: Geological Modelling of a Reservoir in Natural Fractured Granite Basement

By Le Cong Truing
Supervisor: Dr. Pham Huy Giao

Research Study: Managed Pressure Drilling (MPD) and Recent Deployment of MPD Technology in Vietnam

By Nguyen Thanh Ban
Supervisors: Dr. Noppadol Phien-wej / Mr. Sarunphong Articharte

Research Study: One-Dimensional Basin Modeling in Vinh Chau Basin, Southern Vietnam

By Bui My Hien Chi
Supervisor: Dr. Pham Huy Giao

Research Study: Production Forecast Model for the Development of Southwest Vietnam Gas Fields in the North Malay Basin in the Gulf of Thailand

By Doan Quoc Truc
Supervisors: Dr. Pham Huy Giao/ Dr. Suwat Athichanagorn

Research Study: Sealing Capacity Study for Block 16-2, Offshore Vietnam

By Truong Van Thanh
Supervisor: Dr. Pham Huy Giao

Volume Change and Smeared Zone Characteristics of PVD Improved Soft Clay with Vacuum Preloading: Laboratory and Field Investigation



This study presents the analytical and finite element simulations of reconstituted soil sample and natural ground improved with PVD only and combining PVD with vacuum and surcharge preloading. Observations showed that the settlements of 1.273m and 1.336m were obtained with 116days of consolidation. FEM simulations and back calculations revealed that PVD improvement with vacuum preloading is faster than that of normal PVD in the laboratory and field conditions due to the reduced effect of smeared zone and increased coefficient of consolidation during vacuum preloading.

4.5: SET – INDUSTRIAL AND MANUFACTURING ENGINEERING FIELD OF STUDY

4.5.1 Introduction

Industrial and Manufacturing Engineering field of study prepares students for manufacturing management and decision support positions in industry and public sector, by equipping them with a broad range of decision making skills for a variety of applications. The IME curriculum reflects the objective of imparting fundamental knowledge to develop the ability to address complex industrial issues, emphasizing on how to design, operate, control, and optimize the production systems.

4.5.2 Research Facilities and Laboratories

IME field shares all the laboratory facilities with Mechatronics and Microelectronics fields of study. There are several well equipped laboratories with the primary function of supporting the students and faculty for teaching and research and to conduct outreach programs.

Computer Integrated Manufacturing (CIM) Laboratory

The Computer Integrated Manufacturing (CIM) laboratory was officially inaugurated on September 23, 1991. It provides the hardware and software support for Industrial Systems Engineering. Many research activities have been carried out in close collaboration with industry and government sectors in the areas of Computer Aided Design (CAD), Computer Aided Manufacturing (CAM), Computer Numerical Control (CNC), Rapid Prototyping (RP) and Medical Technology. The CIM Laboratory also provides specialized training and consultancy services in CAD, CAM, CNC Machining, Reverse Engineering, Rapid Prototyping, Packaging Technology, Flexible Manufacturing Systems [FMS], and

Development of Postprocessor for 5-axis CNC.

The CIM Laboratory is equipped with production and training CNC machines including EMCO TURN242 industrial production CNC lathe, EMCO VMC200 CNC vertical machining center for universal production, MAHO MH600E2 5-axis universal milling and boring machine, an EMCO compact 5 CNC, an EMCO F1 CNC, a LVD CNC press brake, a LVD water-jet cutting CNC, ZOLLER tool presetting system, and a Mondiale Gallic G-420 Industrial CNC lathe, EMCO CNC training system, Plastic Injection Molding Machine. The available CAD/CAM software includes UNIGRAPHICS NX4, Master CAM 9.1, Mechanical Desktop 6, AutoCAD Inventor Series, SolidWorks 2005, CAM 2000, Mimics 6.3 & Magic 5.4.

Metrology Laboratory

Metrology Laboratory provides the hardware and software support for teaching and research activities in Industrial Systems Engineering. Metrology Laboratory is equipped with Measuring Instruments (Zeiss CMM, Mitutoyo Profile Projector, Taylor Hobson Surface Roughness Tester, Lab View Hardware & Software).

Simulation Laboratory

This lab is equipped with networks of Pentium PC for general applications and internet access, high end CAD/CAM & Simulation software such as ARENA and AutoMOD. In addition, a high performance computer facility with parallel cluster is also available for research use.

4.5.3 Faculty and Research Staff

Full-time Faculty

VORATAS KACHITVICHYANUKUL, BS, Natl Taiwan Univ; MEng, AIT, Thailand; PhD, Purdue Univ, Indiana, USA.

Professor (*Simulation; ERP; Scheduling, Metaheuristics; Parallel Computing*) [*Planning and Scheduling Systems; Enterprise Resource Planning Systems; Supply Chain Modeling and Analysis; Discrete Event Simulation Software Development; Manufacturing System Simulation; Manufacturing Decision Support Systems; Just-in-Time Manufacturing System*]

MARIO T TABUCANON, BSEE, BSME, Cebu Inst of Tech, Philippines; MEng, DEng, AIT, Thailand.

Professor (*Multiple Criteria Decision Making; Operations and Production Management; Operations Research; Project Management; Systems Modeling*)

ERIK L J BOHEZ, Burgerlijk WerktuigKundig Electro- Technisch Ingenieur, Rijks Universiteit Gent (State University Ghent, Belgium); Kandidatuur Burgerlijk Ingenieur, Rijks Universiteit Gent (State University Ghent, Belgium); Technisch Ingenieur Electro-Mechanica, Hoger Technisch Instituut Sint Antonius Gent, (High Technical Institute Saint Antonius Ghent; Belgium).

Associate Professor(*Computer Aided Design; Computer Aided Manufacturing; Computer Graphics; Computer Numerical Control; Five Axis Machining; Robust Control; Simulation of*

Metal Removal; [CNC/CAD/CAM; Five Axis Machining; Mold and Die Design, Eco-Design, Biomechanics, Industrial Packaging]

HUYNH TRUNG LUONG, BEng, Ho Chi Minh City Univ of Tech, Vietnam; MEng; DEng, AIT, Thailand.

Associate Professor [*Emergency inventory policies and inventory policies for perishable products; Supply chain design; Measures of bullwhip effect in supply chains; Availability-based and reliability-based maintenance; Fuzzy quality control charts; Statistical design of experiments; Network flows related problems*]

PISUT KOOMSAP, BEng, Thammasat Univ, Thailand; MSc, Univ of Louisville; PhD, Pennsylvania State Univ, USA

Assistant Professor (*Sensing and Control for Manufacturing Processes and Systems; Laser Applications in Manufacturing; Rapid Prototyping; Condition-Based Maintenance; Continuous Improvement*) [*Rapid Prototyping; Sensing and Control for Manufacturing Processes and Systems; Laser Applications in Manufacturing; Condition-Based Maintenance; Continuous Improvement*]

Visiting Faculty

PRADEEP KUMAR, B.E.(1982), University of Roorkee, M.E. (1989) University of Roorkee, Ph.D. (2004) University of Roorkee

Visiting Professor (*Supply Chain Management (SCM), Advanced Manufacturing Processes; Quality Engineering: Robust Design Methodologies, Reliability Engineering; and Production & Operations Management*)

R. VENKATA RAO, B.Tech. (1988), Nagarjuna University, A.P.; M.Tech.(1991), Banaras Hindu Univ.;

and Ph.D. (2002), B.I.T.S., Pilani, Rajasthan, India. Professor and Head, Dept. of Mechanical Engineering, S.V. National Institute of Technology, Gujarat State, India.

Visiting Professor [*Production and Operations Management, Advanced Manufacturing Technology, Design of Manufacturing Systems, CAD/CAM/CIMS, Fuzzy Multiple Attribute Decision Making Methods, Non-Traditional Optimization Methods*].

4.5.4 Grants and Sponsored Research Completed in 2010

Development of an Automatic Steering Cruise Control System for Passenger Cars

Duration: 01 Nov 07 -31 Dec 10
Project Investigator(s): Manukid Parnichkun
Sponsor: National Electronics and Computer Technology Center, Thailand
Total Contracted Amount (THB): 1,988,000

Multi objectives multi echelon location routing problem: A case study in Bagasses Ethanol plant in Northeastern Thailand

Duration: 01 Aug 09 -31 Dec 10
Project Investigator(s): Voratas Kachivichyanukul
Sponsor: RTG
Total Contracted Amount (THB): 1,000,000

Product and Design Development for Nawaplastic Industries

Duration: 15 Nov 09 -31 May 10
Project Investigator(s): Pisut Koomsap
Sponsor: Nawaplastic Industries (Saraburi) Co. Ltd
Total Contracted Amount (THB): 135,890

The Third International Conference on Management Science and Engineering Management

Duration: 01 Sep 09 -30 Apr 10
Project Investigator(s): Voratas Kachivichyanukul
Sponsor: Multi donors
Total Contracted Amount (THB): 1,000,000

4.5.5 On-going Grants and Sponsored Research

Carbon footprint of Double A Paper and Development of Life Cycle Management System

Duration: 01 Nov 09 - 01 May 11
Project Investigator(s): Erik Bohez
Sponsor: RTG/Advanced Agro
Total Contracted Amount (THB): 2,000,000

Identify Customer Needs from Voice of Customers for SCG Building Materials

Duration: 01 Feb 10 - 31 Jan 11
Project Investigator(s): Pisut Koomsap
Sponsor: SCG Building Materials Co Ltd
Total Contracted Amount (THB): 149,800

Life Cycle Assessment Fine Paper

Duration: 01 Jun 08 - 31 May 11
Project Investigator(s): Erik Bohez, Esa Viljakainen
Sponsor: Double A
Total Contracted Amount (THB): 1,475,000

Product Design & development for SCG Building Material 2009

Duration: 01 Aug 09 - 31 Dec 11
Project Investigator(s): Pisut Koomsap
Sponsor: SCG Building Materials Co Ltd
Total Contracted Amount (THB): 101,650

Product design and development for Thai Ceramic Co. Ltd

Duration: 21 May 10 - 20 May 11
Project Investigator(s): Pisut Koomsap
Sponsor: Thai Ceramic Co Ltd
Total Contracted Amount (THB): 321,000

Project on Human Resource Development in Multi-Axis CNC Machine for EGAT

Duration: 01 Feb 07 - 31 May 11
Project Investigator(s): Erik Bohez
Sponsor: EGAT Public Company, Thailand
Total Contracted Amount (THB): 750,000

The development of Automatic Flat screen Printing Machine

Duration: 01 Aug 09 - 30 Jun 11
Project Investigator(s): Pisut Koomsap
Sponsor: RTG
Total Contracted Amount (THB): 950,000

4.5.6 Publications

International Journal Articles with Impact factor

Astanti R.D., Huynh TrungLuong. A heuristic technique for inventory replenishment policy with increasing demand pattern and shortage allowance. *International Journal of Advanced Manufacturing Technology*, 11-12(41) 0-0, 2010.

Dang N.M., Mukand S. Babel, Huynh TrungLuong. Evaluation of food risk parameters in the Day River Flood Diversion Area, Red River Delta, Vietnam. *Natural Hazards*, () 0-0, 2010.

Duc T.T.H., Huynh TrungLuong, Kim Y.-D.. Effect of the third-party warehouse on bullwhip effect and inventory cost in supply chains. *International Journal of Production Economics*, 2(124) 0-0, 2010.

Dumsong E., Nitin V. Afzulpurkar, AdisornTuantranont. Design, analytical modeling, and simulation of wire-free walking scratch-drive microrobot. *IEEE Transactions on Industrial Electronics*, 4(56) 0-0, 2010.

Kachitvichyanukul, V. and Nguyen, S. Evolutionary Strategies to Find Pareto Fronts in Multiobjective Problems, In: *Applications of Swarm Intelligence*, Editors: Louis P. Walters, ISBN: 978-1-61728-602-5, © Nova Science Publishers, Inc., 2010

Kasemset C., Voratas Kachitvichyanukul. Bi-level multi-objective mathematical model for job-shop scheduling: The application of theory of constraints. *International Journal of Production Research*, 20(48), 6137–6154, 2010.

Kuagoolkijgarn P., Pisut Koomsap, ChansriN.. A new algorithm for tracing nests of interconnected contours. *International Journal of*

Advanced Manufacturing Technology, () 0-0, 2010.

Nguyen, S. and Kachitvichyanukul, V. Movement strategies for multi-objective Particle Swarm Optimization, *International Journal of Applied Metaheuristic Computing*, 1(3), 59-79, July-September 2010

Rianmora S., Pisut Koomsap, van HaiD.P.. Selective data acquisition for direct integration of reverse engineering and rapid prototyping. *Virtual and Physical Prototyping*, 4(4) 0-0, 2010.

Rianmora S., Pisut Koomsap. Recommended slicing positions for adaptive direct slicing by image processing technique. *International Journal of Advanced Manufacturing Technology*, 9-12(46) 0-0, 2010.

Sombuntham, P. and Kachitvichyanukul, V. Multi-depot Vehicle Routing problem with Pickup and Delivery Requests, *IAENG Transactions on Engineering Technologies Volume 5*, America Institute of Physics, pp. 71-85, October 2010, doi:10.1063/1.3510581

Sonthipermpon K., Erik L. J. Bohez, Hasemann H., Rautenberg M.. The vibration behavior of impeller blades in the five-axis CNC flank milling process. *International Journal of Advanced Manufacturing Technology*, 9-12(46) 0-0, 2010.

Sooksaksun, N., Kachitvichyanukul, V., and Gong, D.C. Performance Comparison of Different Warehouse Layouts under a Class-based Storage Policy, *International Journal of Logistics and SCM Systems*, Vol. 10, No. 1, pp. 141-148, March 2010

Soonanon P., Pisut Koomsap. Towards direct transformation of orthographic-view drawings into a prototype. *Virtual and Physical Prototyping*, 2(4) 0-0, 2010.

Suthunyanakit K., Erik L. J. Bohez, AnnanonK.. A polyhedral-based approach of accessibility computation for a NURBS model in tool-based manufacturing. *Computer-Aided Design and Applications*, 1(7) 0-0, 2010.

Ugsornrat K., Nitin V. Afzulpurkar, Wisitsoraat A., AdisornTuantranont. Design, simulation, and experimental study of a droplet-based PCR by EWOD. *Sensors and Materials*, 6(22) 0-0, 2010.

Venkata Rao Ravipudi, Manukid Parnichkun. Flexible manufacturing system selection using a combinatorial mathematics-based decision-making method. *International Journal of Production Research*, 24(47) 0-0, 2010.

Yiangkamolsing C., Erik L. J. Bohez, Ingo Bueren. Universal design (UD) principles for flexible packaging and corresponding minimal customer requirement set. *Packaging Technology and Science*, 5(23) 0-0, 2010.

Conference Publications

Aziz, M.H., Bohez, E.L.J., Parnichkun, M., Saha, C. Classification of Fuzzy Petri Nets, and their applications, *Proceedings of World Academy of Science, Engineering and Technology*

Chivapornthip P., Erik L. J. Bohez, Nanthavanij S., Sitthiseripratip K., Lorprayoon E.. Biomechanics of index finger during mouse click. *IFMBE Proceedings*, (27) 0-0, 2010.

Hieu L.C., Erik L. J. Bohez, Sloten J.V., Le Thanh Hung, KhanhL.. Integrated approaches for personalised cranio-maxillofacial implant design and manufacturing. *IFMBE Proceedings*, (27) 0-0, 2010.

Kasemset C., Voratas Kachitvichyanukul. Effect of Confidence Interval on Bottleneck

Identification via Simulation, 2010
IEEE Conference on Industrial Engineering and Engineering Management (IEEM), December 2010, Macau, pp1592-1595.

Phromfaiy, A., Sonthipermpon, K., Bohez, E. Grinding path optimization for a roll grinding machine, IEEE International Conference on Industrial Engineering and Engineering Management, IEEM2010; Macao; 7-10 December 2010

Sombuntham, P. and Kachitvichyanukul, V. A Particle Swarm Optimization Algorithm for Multi-depot Vehicle Routing problem with Pickup and Delivery Requests, Lecture Notes in Engineering and Computer Science: Proceedings of The International MultiConference of Engineers and Computer Scientists 2010, IMECS 2010, 17-19 March, 2010, Hong Kong, pp1998-2003.

Sooksaksun, N., Kachitvichyanukul, V. Comparison of One-block and Two-block Layout Configuration in Warehouse Design, The 2nd International Conference on Logistics and Transport 2010, Christchurch, New Zealand, December 2010

Sooksaksun, N., Kachitvichyanukul, V. Particle Swam Optimization for Warehouse Design Problem, Proceedings of the 11th Asia Pacific Industrial Engineering and Management Systems Conference, APIEMS 2010, December, 2010, Volume 72, December 2010, Pages 394-401

Wisittipanich, W. and Kachitvichyanukul, V. Differential Evolution Algorithm for Job Shop Scheduling Problem, Proceedings of the 11th Asia Pacific Industrial Engineering and Management Systems Conference, APIEMS 2010, December, 2010

4.5.7 Doctoral Students' Dissertation

Design and Manufacturing Engineering

Computer-Aided Simulation of Cooling System for Electronics Components

By Banjerd Saengchandr
Supervisor: Dr. Nitin V. Afzulpurkar

Development of Adaptive Reverse Engineering System to Support Rapid Product Development

By Suchada Rianmora
Supervisor: Dr. Pisut Koomsap

4.5.8 Masters Students Theses and Projects

A Decision Support System for Integrated Production Planning and Scheduling Decisions in Practical Job Shops

By Tharinan Rattanalert
Supervisor: Dr. Voratas Kachitvichyanukul

A Study of the Theory of Constraints: A Comparison of Traditional DBR with Simplified DBR

By Tran Quang Chi
Supervisor: Prof. Voratas Kachitvichyanukul

Biomechanics of the Index Finger During Mouse Clicks

By Prapol Chivapornthip
Supervisor: Dr. Erik L. J. Bohez

Carbon Footprint of Parawood Chair: A Case Study of Topworld Industries

By Pataravit Chevathamamon
Supervisor: Assoc. Prof. Erik L. J. Bohez

Effect of Third-Party Warehouse on Bullwhip Effect in Supply Chains with Stochastic Lead Time

By Sirikan Tachateerawat
Supervisor: Dr. Huynh Trung Luong

Enhancing a Customer Design by for Multi-Color Nested Pattern Products

By Thawanporn Suthamviwat
Supervisor: Dr. Pisut Koomsap

Environmental Impacts on the Transportation Systems of "Double A

Paper" Using the Life Cycle Assessment Method

By Chawit Chongwilaiwan
Supervisor: Dr. Erik L. J. Bohez

Life Cycle Assessment of Glass Containers: A Case Study of Bangkok Glass Disposable Singha Soda Water

By Kannika Khantharam
Supervisor: Assoc. Prof. Erik L. J. Bohez

PSO Algorithms for Generalized Multi-Depot Vehicle Routing Problems with Pickup and Delivery Requests

By Pandhapon Sombuntham
Supervisor: Dr. Voratas Kachitvichyanukul

Simultaneous Scheduling of Quay Cranes and Yard Cranes Via Particle Swarm Optimization

By Opas Ovasith
Supervisor: Prof. Voratas Kachitvichyanukul

Steady-State Airflow and Particle Trajectories Inside a Hard Disk Drive

By Chanchal Saha
Supervisor: Dr. Huynh Trung Luong

The Analysis and Optimization of Hydro Turbine Runner for a Minihydro System

By Karan Sengpanich
Supervisor: Dr. Erik L. J. Bohez

Project: A Multivariate Control Chart to Monitor and Control a Process at the Ammonia Unit of Phumy Fertilizer Plant

By Nguyen Van Nhung
Supervisor: Dr. Huynh Trung Luong

Project: An Age-Dependent Selective Maintenance Policy for a Gas Processing Plant in Vietnam

By Nguyen Kim Ngoc
Supervisor: Dr. Huynh Trung Luong

Project: Applying the Bayesian Belief Network-Based Model to Quantify a Schedule Risk in Block B-Omon Gas Pipeline Project in Vietnam

By Nguyen Manh Tuong
Supervisor: Prof. Voratas Kachitvichyanukul

Project: A Simulation Model for a Cost-Based Selective Maintenance Policy with Time-Window Constraint

By Nguyen Xuan Tinh
Supervisor: Prof. Voratas Kachitvichyanukul

Project: A Simulation Model for an Availability-Based Selective Maintenance Policy of a Serial System with Time-Window and Budget Constrains

By Le Hoang Ngoc Bau
Supervisor: Dr. Huynh Trung Luong

Project: Development of a Project Cost Control Framework for Wellhead Platform Fabrication Projects in Petrovietnam

By Nguyen Thi Phuong Thi
Supervisor: Prof. Voratas Kachitvichyanukul

Project: Establishment of Control Charts to Help Monitor and Evaluate the Steam Boiler Performance at Phu My fertilizer Plant in Vietnam

By Tran Ngoc Thuong
Supervisor: Dr. Huynh Trung Luong

Project: Fabrication Process Analysis and Improvement at PTSC Offshore Services Company Limited, Vietnam

By Truong Ngoc Nguyen
Supervisor: Prof. Voratas Kachitvichyanukul

Project: Facility Location and Allocation Model for a Compressed Natural Gas Distribution Network in Vietnam

By Phan Tan Hau
Supervisor: Prof. Voratas Kachitvichyanukul

Project: Integration of Quality, Safety, and Environment Management Systems: A Case Study for Petrovietnam Gas Corporation in Vietnam

By Le Thanh Hai
Supervisor: Prof. Voratas Kachitvichyanukul

Project: Inventory Control Policy for Consumable Goods and Spare Parts of PVD Well Services Company Ltd.

By Dinh Quang Tam
Supervisor: Dr. Huynh Trung Luong

Project: Maintenance Approach for an Emergency Shutdown System (ESD) in Phu My Fertilizer Plant, Vietnam

By Vo Van Ngoc
Supervisor: Prof. Voratas Kachitvichyanukul

Project: Multivariate Control Chart for Urea Processing Unit of Phu My Fertilizer Plant in Vietnam

By Nguyen Tri Thien
Supervisor: Dr. Huynh Trung Luong

Project: Optimization of Gaslift Distribution to Wells in the Offshore Facilities of Cuulong Joint Operating Company (CLJOC) in Vietnam

By Vu Minh Duc
Supervisor: Dr. Huynh Trung Luong

Project: Optimizing Production from Gaslift Wells in Sutuden Oil Field-Offshore Vietnam

By Ly Van Dao
Supervisor: Prof. Voratas Kachitvichyanukul

Project: Quality Control of Produced Water Overboard on Central Processing Platform-SU Tu Vang Oil Field, Vietnam

By Nguyen Anh Duc
Supervisor: Dr. Huynh Trung Luong

Project: Scheduling Methods for Optimal Operation of Jetties

By Vu Van Hai
Supervisor: Prof. Voratas Kachitvichyanukul

Project: Statistical Process Control Chart to Help Control the Process Quality of Inlet Gas Booster Compressors at a Gas Processing Plant in Vietnam

By Pham Nguyen Quoc Cuong
Supervisor: Dr. Huynh Trung Luong
Project: The Application of XMR and Cusum Charts for Quality Control at Phu My Fertilizer Plant, Vietnam
By Bui Hoang Nam
Supervisor: Dr. Huynh Trung Luong

Project: The Bull Whip Effect in Supply Chains by Use of Simulation - The Case of (Q,R) Inventory Policy with Independent Poisson Demand

By Nguyen Duc Dung
Supervisor: Dr. Huynh Trung Luong

Project: The Bull Whip Effect in Supply Chains Through Simulation - The Case of (Q,R) Inventory Policy with Independent and Normally Distributed Demand

By Le Thanh Trung
Supervisor: Dr. Huynh Trung Luong

Project: The Need for a Coal Supply Chain in Petrovietnam: A Facility Location Related Problem

By Doan Van Cuong
Supervisor: Prof. Voratas Kachitvichyanukul

Industrial Engineering & Management

Development of a Simulation-Based System to Support Short-Term Operation Planning in Job Shop

By Ploypailin Piromsopa
Supervisor: Prof. Voratas Kachitvichyanukul

Development of an Automatic Steering Cruise Control System for Passenger



The main objective of this project is to develop an automatic steering cruise control system which can be installed in passengers in the market. The automatic steering cruise control system controls both speed and steering direction of the car. The system is to be stable and able to work in various environments by applying sensor fusion technique. Steering direction control function allows the car to follow direction of the front car or to track road traffic line enabling the car to run on a straight or a curvature road automatically. The automatic steering cruise control system is taken over by the driver immediately after the driver rolls the steering wheel manually. The system takes charge again when the driver release the steering wheel.

4.6: SET – MECHATRONICS and MICROELECTRONICS & EMBEDDED SYSTEMS

FIELDS OF STUDY

4.6.1 Introduction

Mechatronics

At present, most academic institutions and industries in the Asian region are only system integrators. Components are procured from more developed countries (e.g. computer numerically controlled machines, robots, and automated guided vehicles) and are integrated as a system (e.g. flexible manufacturing system). To support the growth of the region's economy, expertise not only as system integrators but also as builders of components of advanced technologies must be developed. The growing number of electronic devices and the strong interactions between mechanical and electronic parts no longer permit separate investigations of these components.

Mechatronics provides new insights through an integrated consideration of mechanics, electronics and information technology. The curriculum is designed to provide multidisciplinary knowledge and to develop the ability to design mechatronics systems.

Microelectronics and Embedded Systems

The region's growing industrial sector and the increasing demand for high technologies have brought the need for expertise in microelectronics to a critical level. The students are prepared to cope with the needs of the electronics industry in the region. The curriculum is equally balanced between the analog and digital design of circuits as well as the processing related topics including failure analysis, suitable for this electronics industrial sector in the

region. The curriculum has been designed and constantly adapted in partnership with microelectronics industries and collaborating universities overseas.

Miniaturisation of IC and the possibilities of completely new technologies like nanotechnology have also been introduced.

4.6.2 Research Facilities and Laboratories

Mechatronics and Microelectronics and Embedded Systems fields of study share all the laboratory facilities with the Industrial & Manufacturing Engineering field of study. There are several well equipped laboratories with the primary function of supporting the students and faculty for teaching and research and to conduct outreach programs.

Mechatronics and Automation Laboratory

The Mechatronics and Automation laboratory is well equipped with many PLC systems (S5, S7200/300/400, INDRAMAT, BOSCH), distributed control systems (PCS7), operator panels (OP5, OP17/DP and OP35), a PC-based human machine interface package (WINCC) and networked field buses (PROFIBUS, INTER-BUS and SERCOS). The lab has mobile robots (NOMAD, PIONEER 2), robot arms (CRS), an industrial robot (KUKAKR15), a self-made open architecture CNC machine, CNC control systems (MTC200, SINUMERIK 8100/8400), image processing systems (DVT, MATROX) and FPGA's (XILINX-1i VIRTEX PRO, ALTERA). Software such as SYNOPSIS IC Design, ANYSIM, ANSYS, ADAMS and many types of special sensors and actuators are also available for research use.

The Integrated Circuit Design laboratory gives students access to a wide variety of professional software applications including ANSYS, Orcad, ModelSim SE, Xilinx ISE, Synopsys, Leonardo Spectrum LS and Tanner (S-Edit for Schematic Capture, T-Spice and W-Edit for Simulation and LEdit for Physical Layout). The laboratory's facilities are used for analog and digital circuit design, microchip design and fabrication, MEMS, microactuators and micro-sensors design, computational electronics, and so on. Fabrication facilities are available through the National Electronics Technology Center and the National Science and Technology Development Administration located in nearby Science Park.

Mechatronics faculty and students work in close collaboration with industry and government sectors in the areas of industrial automation, robotics, control, system design and integration. Some examples of ongoing projects include a medical tele-analyzer, automated visual inspection systems, MEMS design, an autonomous flying robot, automating centrifuge machines, an autonomous underwater robot and automating crystallization processes.

Simulation Laboratory

This lab is equipped with networks of Pentium PC for general applications and internet access, high end CAD/CAM & Simulation software such as ARENA and AutoMOD. In addition, a high performance computer facility with parallel cluster is also available for research use.

IC Design Laboratory

The Integrated Circuit Design laboratory gives students access to a

wide variety of professional software applications including ANSYS, Orcad, ModelSim SE, Xilinx ISE, Synopsys, Leonardo Spectrum LS and Tanner (S-Edit for Schematic Capture, T-Spice and W-Edit for Simulation and LEdit for Physical Layout). The laboratory's facilities are used for analog and digital circuit design, microchip design and fabrication, MEMS, microactuators and micro-sensors design, computational electronics, and so on. Fabrication facilities are available through the National Electronics Technology Center and the National Science and Technology Development Administration located in nearby Science Park.

4.6.3 Faculty and Research Staff

Full-time Faculty

JOYDEEP DUTTA, BSc (Hons), St Edmund's College; MSc (Physics), North Eastern Hill Univ; PhD, IACS, Calcutta Univ, India.

Professor [Functional materials, nanomaterials, Nanoparticles, selforganisation, Biomimetic processes, Polyelectrolyte deposition, Gas sensors, Bio-sensors, optoelectronic devices]

MANUKID PARNICHKUN, BEng, Chulalongkorn Univ, Thailand; MEng, PhD, Univ of Tokyo, Japan

Associate Professor [Robotics, control, and measurement (involves with design and development of hardware and software of mechatronics devices); New robot mechanism, novel control algorithm, and innovative measurement concept are investigated]

NITIN V AFZULPURKAR, BEng, Univ of Poona, India; PhD, Univ of Canterbury, New Zealand

Associate Professor [Computer vision (pattern recognition and image processing); MEMS design, fabrication for electronic

and bio medical applications; Soft computing algorithms for robotics and automation applications; Mechatronics applications for industrial use]

MONGKOL EKPANYAPONG, B.Eng., Chulalongkorn Univ, Thailand; M.Eng. Asian Institute of Technology, Thailand, M.Sc., Ph.D., Georgia Institute of Technology, USA

Assistant Professor [Embedded Systems, Computer Architecture, VLSI design (Low power design), Physical VLSI design, High Performance Computing, GPGPU, DSP]

Visiting Faculty

JAMUNA KANTA SING, B.E. (1992) Jadavpur University Kolkata, M.Tech. (1993) Indian Institute of Technology, Kharagpur, Ph.D. (2006) University, Kolkata

Visiting Professor (Human face detection, recognition and tracking and medical image analysis.)

YANNICK Aoustin, Ph.D. (1987) University of Nantes.

Visiting Professor (Control of Robots, especially control of robot manipulators and Humanoid robots).

RENATO ZACCARIA

Visiting Professor (Advanced Robotics).

FULVIO MASTROGIOVANNI, Ph.D. (2008) University of Genova

Visiting Professor (Formalization and representation of knowledge, tasks and actions using simboli and sub symbolic techniques).

MASASHI SHIMIZU, Ph.D. (1965) in Mechanical Engineering, School of Engineering, Tohoku University.

Visiting Professor (Mechanical Engineering)

VIJAY JANYANI, B.E. (1994) Malaviya Regional Engineering College, Jaipur,

M.E. (1996) Regional Engineering College, Jaipur, Ph.D. (2005) at School of Electronics and Electrical Engineering at Nottingham University (UK).

Visiting Professor

(Microelectronics Devices, Numerical Modelling, Electronics and Communication Systems, Optical Communication Devices and Systems, Time-domain numerical modeling and simulation of nonlinear and dispersive optoelectronic materials and devices, photonic crystal structures, components and waveguides).

KONDEPUTI LAL KISHORE, B.E.

Osmania University, M.Tech. Indian Institute of Science, Bangalore, Ph.D. (1986) at India Institute of Science, Bangalore, India.

Visiting Professor (Micro Electronics and VLSI Engineering).

Adjunct Faculty

PUDIT LAKSANACHAROEN, Ph.D.

(2001) Case Western Reserve University, Cleveland, Ohio, USA (Model and Simulation for Design and Control of Legged Robots)

ADRIANO JOSE DA CONCEICAO TEVARES, Ph.D. (2000) University of Minho, Portugal (Industrial Electronics)

JOAO L. MONTEIRO, Ph.D. (2000) in Informatics Computer Engineering, University of Minho, Portugal (Electrical Engineering)

4.6.4 Grants and Sponsored Research Completed in 2010

Automated Inline Foam Sheet Placement and Adhesion

Duration: 01 Jun 07 -31 Dec 10

Project Investigator(s): Nitin Afzulpurkar

Sponsor: RTG-CPAC Roof Tile Co. Ltd

Total Contracted Amount (THB): 1,500,000

Disk Drive Automated Test Operation Modelling for Throughput Predicting Controlling and Monitoring

Duration: 15 Sep 08 -15 Sep 10
 Project Investigator(s): Nitin Afzulpurkar
 Sponsor: Seagate Technology Th Ltd/RTG
 Total Contracted Amount (THB): 900,000

Master Degree in HDD Engineering Technology

Duration: 01 Jul 07 -31 May 10
 Project Investigator(s): Nitin Afzulpurkar
 Sponsor: Western Digital Co. Ltd.
 Total Contracted Amount (THB): 10,528,000

Master Degree in HDD Engineering Technology-Batch 2

Duration: 01 Jul 08 -31 Dec 10
 Project Investigator(s): Nitin Afzulpurkar
 Sponsor: Western Digital Co. Ltd.
 Total Contracted Amount (THB): 10,528,000

Police Eyes

Duration: 01 Aug 10 -30 Nov 10
 Project Investigator(s): Mongkol Ekpanyapong
 Sponsor: NECTEC, Thailand
 Total Contracted Amount (THB): 200,000

4.6.5 On-going Grants and Sponsored Research

Microelectronics

Brain computer interface based mental detection for accident prevention and Machine control: Applications in Fatigue alarming and Robot control

Duration: 01 Jul 09 - 31 Dec 11
 Project Investigator(s): Manukid Parnichkun
 Sponsor: RTG
 Total Contracted Amount (THB): 1,000,000

Development of Force Feedback Exoskeleton system for Virtual Reality

Duration: 01 Nov 08 - 31 Dec 11
 Project Investigator(s): Manukid Parnichkun
 Sponsor: RTG
 Total Contracted Amount (THB): 952,000

Development of Robot Controller

Duration: 01 Nov 08 - 31 Oct 11
 Project Investigator(s): Manukid Parnichkun
 Sponsor: Aerofluid Co Ltd/RTG
 Total Contracted Amount (THB): 2,000,000

Electronic design using GP-GPU for performance improvement

Duration: 16 Jun 10 - 15 Jun 12
 Project Investigator(s): Mongkol Ekpanyapong
 Sponsor: TRF

Total Contracted Amount (THB): 360,000

Flow Modeling in Hard disc Drives

Duration: 15 Dec 09 - 31 Dec 11
 Project Investigator(s): Joydeep Dutta,Huynh Trung Luong ,Pisut Koomsap
 Sponsor: Donaldson Company Thailand
 Total Contracted Amount (THB): 1,000,000

Master Degree in HDD Engineering Technology #3

Duration: 01 Jul 09 - 01 Jul 11
 Project Investigator(s): Nitin Afzulpurkar
 Sponsor: Western Digital Co. Ltd.
 Total Contracted Amount (THB): 10,528,000

Master Degree in HDD Engineering Technology #4

Duration: 01 Jul 10 - 01 Jul 12
 Project Investigator(s): Nitin Afzulpurkar
 Sponsor: Western Digital Co. Ltd.
 Total Contracted Amount (THB): 10,528,000

Simulation Model for reducing Spring Constant in HDD Suspension

Duration: 01 Dec 08 - 31 Jan 11
 Project Investigator(s): Nitin Afzulpurkar
 Sponsor: I/U CRC Advanced Manufacturing
 Total Contracted Amount (THB): 500,000

4.6.6 Publications

International Journal Articles with Impact factor

Abbasi A.R., Matthew Dailey, Nitin V. Afzulpurkar, Uno T.. Student mental state inference from unintentional body gestures using dynamic Bayesian networks. Journal on Multimodal User Interfaces, 1(3) 0-0, 2010.

Aphiratsakun N., Manukid Parnichkun. Balancing control of AIT leg exoskeleton using ZMP based FLC. International Journal of Advanced Robotic Systems, 4(6) 0-0, 2010.

Bodhale D.W., Nisar A., Afzulpurkar N.. Structural and microfluidic analysis of hollow side-open polymeric microneedles for transdermal drug delivery applications. Microfluidics and Nanofluidics, 3(8) 0-0, 2010.

Dumsong E., Nitin V. Afzulpurkar, Adisorn Tuantranont. Design, analytical modeling, and simulation

of wire-free walking scratch-drive microrobot. IEEE Transactions on Industrial Electronics, 4(56) 0-0, 2010.

Kaitwanidvilai S., Jangwanitlert A., Manukid Parnichkun. Structured robust loop shaping control for HIMAT system using PSO. AIP Conference Proceedings, (1089) 0-0, 2010.

Kiatpanichagij K., Nitin V. Afzulpurkar. Use of supervised discretization with PCA in wavelet packet transformation-based surface electromyogram classification. Biomedical Signal Processing and Control, 2(4) 0-0, 2010.

Maneetham D., Nitin V. Afzulpurkar. Modeling, simulation and control of high speed nonlinear hydraulic servo system. World Journal of Modelling and Simulation, 1(6) 0-0, 2010.

Tongsomporn D., Nitin V. Afzulpurkar, Sitthisak O.. A study of head instabilities in TMR sensors using in high density perpendicular magnetic recoding systems. International Journal of Applied Electromagnetics and Mechanics, 4(31) 0-0, 2010.

Ugsornrat K., Nitin V. Afzulpurkar, Wisitsoraat A., Adisorn Tuantranont. Design, simulation, and experimental study of a droplet-based PCR by EWOD. Sensors and Materials, 6(22) 0-0, 2010.

Venkata Rao Ravipudi, Manukid Parnichkun. Flexible manufacturing system selection using a combinatorial mathematics-based decision-making method. International Journal of Production Research, 24(47) 0-0, 2010.

Conference Publication

Bodhale D.W., Nisar A., Nitin V. Afzulpurkar. Design, fabrication and analysis of silicon microneedles for transdermal drug delivery

applications. IFMBE Proceedings, (27) 0-0, 2010.

Jednipat Moonrinta_, Supawadee Chaivivatrakul_, Matthew N. Dailey, and Mongkol Ekpanyapong, Fruit Detection, Tracking, and 3D Reconstruction for Crop Mapping and Yield Estimation, The International Conference on Control, Automation, Robotics and Vision (ICCARV), Singapore 2010

Sarayut Amornwongpeeti, Mongkol Ekpanyapong and Chumnarn Punyasai, A Study of Non-Ideality Effects on Third-order Cascaded Multi-bit Delta-Sigma Modulator with Interstage Feedback Paths, International Technical Conference on Circuits/Systems, Computers and Communications (ITC-CSCC) 2010

Sarayut Amornwongpeeti, Mongkol Ekpanyapong and Chumnarn Punyasai, A Comparative Analysis of Behavioral Simulation for Third-Order Cascaded Multi-Bit Delta-Sigma Modulator with Interstage Feedback Paths, Electrical Engineering/Electronics, Computer, Telecommunications and Information Technology (ECTI) Association (ECTI) 2010

4.6.7 Doctoral Students' Dissertation

Mechatronics

Balancing Control of AIT Leg Exoskeleton
By Narong Aphiratsakun
Supervisor: Dr. Manukid Parnichkun

Microelectronics

Design, Simulation and Experimental Study of a Droplet-Based PCR by Electrowetting on Dielectric
By Kessararat Ugsornrat
Supervisor: Dr. Nitin V Afzulpurkar

4.6.8 Masters Students' Theses and Research Studies

Mechatronics

A Pan-Tilt Head Position System for Thermal and CCD Dual Sensors
By Thanit Hanpongsachitt
Supervisor: Dr. Nitin V. Afzulpurkar

Automated Pick and Place Based Machine Vision for Hard Disk Drive Assembly
By Saravut Ashametra
Supervisor: Dr. Nitin V. Afzulpurkar

Balancing Control of a Bicycle Robot by Centrifugal Force
By Pranartpol Pongpaew
Supervisor: Dr. Manukid Parnichkun

Controller and Resonance Compensator Optimization for Head Positioning System in HDD
By Boworn Panyavoravaj
Supervisor: Dr. Manukid Parnichkun

Conveyor System Design for HGA Automation
By Parag Kishor Chhajed
Supervisor: Dr. Nitin V. Afzulpurkar

Couple-Field Analysis for 500KTP1 HDD Dual Stage Actuator for Optimization of Low Power Consumption
By Jarruek Leekliang
Supervisors: Dr. Nitin V. Afzulpurkar / Dr. Adisorn Tuantranont

Development of a COPD (Chronic Obstructive Pulmonary Disease) Measuring Device Using Thermistor for Flow Measurement
By Siddhesh Mangesh More
Supervisor: Dr. Manukid Parnichkun

Dynamic Obstacle Avoidance for Intelligent Vehicle Using 3D LIDAR Scan
By Parkpoom Kerdtanamongkol
Supervisor: Dr. Manukid Parnichkun

Road Profile Estimation Using Road Edge Detection of Left-Right Cameras
By Alisa Kunapinun
Supervisor: Dr. Manukid Parnichkun

Robust Inspection and Roi Adaptation Algorithm for NDT Swage Torque Test Process
By Nara Srielang
Supervisor: Dr. Nitin V. Afzulpurkar

Simulation Model for Reducing Spring Constant (Kv) in HDD Suspension After the Forming Process
By Sanga Kongkaew
Supervisor: Dr. Nitin V. Afzulpurkar

Swing Up and Balance Control of a Dual-Inverted Pendulum
By Sorawuth Vatanashevanopakorn
Supervisor: Dr. Manukid Parnichkun

Vision-Based Automatic Hovering Control of a Small-Scale Unmanned Helicopter
By Apisit Aroonual
Supervisor: Dr. Manukid Parnichkun

Research Study: Analysis of MEMS Based Heparin Infusion Pump for Wearable Artificial Kidney System (WAK)
By Naveed Sheikh
Supervisor: Dr. Nitin V. Afzulpurkar

Microelectronics

A Fourth-Order Cascaded Multi-bit Delta-Sigma Modulator with Interstage Feedback Paths
By Sarayut Amornwongpeeti
Supervisor: Dr. Mongkol Ekpanyapong

Feasibility Study of Close Loop Dynamic Flying Height Based on Readback Signal Amplitude
By Phuwaret Uadkla
Supervisor: Mr. Brent Bargmann

Improved Performance on Gas Sensors Based on Zinc Stannate Nanostructures
By Aarthy Sivapunniam
Supervisor: Prof. Joydeep Dutta

MR Resistance Touchdown-Backoff Calibration on a Multi-Disk Servo Writer
By Bundit Jangsrirert
Supervisor: Dr. Nitin V. Afzulpurkar

Research Study: Protein Sensor for the Waste Dialysate Material
By Jafar Khan Kasi
Supervisor: Dr. Nitin V. Afzulpurkar

4.7: SET – NANOTECHNOLOGY FIELD OF STUDY



4.7.1 Introduction

The **program in Nanotechnology** at AIT is designed to address the knowledge-based industries that will require continuous development of their workforce. Nanotechnology master's and doctoral program are a well-recognized means of gaining experience in state-of-the-art techniques and applications. The program at AIT is addressed to the needs of engineers and science background students for entering into this all encompassing-technology area which is recognized as the manufacturing technology of the 21st century. Nanotechnology with a focus on nanomaterials engineering at AIT provides international level engineering program which is a unique blend of truly cross-disciplinary teaching with an integrated curriculum. Budding Nanotechnologists come from different disciplines, including various engineering disciplines, physics, materials sciences and chemistry, so the postgraduate program in nanotechnology accommodates students from a wide range of backgrounds. Partnership in learning and research with the corporate world is been one of the hallmarks of this program. AIT and PSG Institute of Advanced Studies (PSGIAS) will jointly offer Bachelor's and Master's programs in the field of Nanotechnology to be launched in 2011.

4.7.2 Research Facilities and Laboratories

Research facility in the Nanotechnology laboratory is available through the facilities of the center of Excellence in Nanotechnology, which is one of the 8 designated centers supported by the National Nanotechnology Center (NANOTEC) of the National Science and Technology Development Agency (NSTDA), Thailand. The unifying concept in the laboratory is to utilize wet-chemical methods to fabricate innovative materials and futuristic devices. Applications of nanoparticles in Energy, Food & Agriculture and the environment are the major focus of the research activities. Current research activities focuses on dye-sensitized solar cells, piezotronic devices, methanol reforming for hydrogen production, gas sensors, bio-diagnostic tools, environmental mitigation through visible light photocatalysis, bio-mimicked self-organisation of nanoparticles, and layer-by layer growth of sensing devices from colloidal particles, amongst others.

Nanotechnology Center of Excellence (CoEN)

The Center of Excellence in Nanotechnology addresses the creation of knowledge in areas relevant to industries. Activities

include joint research with other local and international universities and institutes, education and training personnel in the field of nanotechnology, technology transfer and promotion of public and industrial awareness of nanotechnology. This center provides international platform for academicians and researchers from the region, AIT and our partnered universities worldwide to work together with the industries. Activities of the CoE at AIT include, but not exclusively, research and development focused on the application of nanoparticles, nanomaterials, devices and sensors. The CoE supports innovative research suited to the region, education and training of highly qualified personnel and in increasing public and industrial awareness of nanotechnology, amongst other activities like arranging conferences, workshops etc.

Members of the Center of Excellence in Nanotechnology have published over 100 research papers in peer-reviewed journals and international conference proceedings, articles and book chapters since its inception in 2006. Wide ranging collaboration with multinationals and smaller companies in the region includes Donaldson Inc. (USA), Rak

Investment Co. (UAE), SVI Company Ltd. and Western Digital (Thailand), Advance Nanotec(India) and NanoThread Inc. (USA). The center of excellence in Nanotechnology has extensive research collaborations with State University of New York, Buffalo and University of California (Berkeley) (USA), Swiss Federal Institute of Technology-Lausanne (Switzerland), Uppsala University and Royal Institute of Technology (Sweden), Agharkar Research Institute and S. N. Bose Center for Basic Sciences (India), Chulalongkorn University, Prince of Songkhla University, Naresuan University, NANOTEC/NSTDA (all in Thailand), amongst others.

The Center of Excellence in Nanotechnology organized many events in 2010. On 23rd September 2010 a Nanotechnology forum was organized at AIT. Prof. Sirirung Songsivilai (Executive Director, NANOTEC); Dr. Meyya Meyyappan, Chief Scientist for Exploration Technology, NASA Ames Research Center, USA; Prof. Heinrich Hofmann, Director, The ERU Surface Coating and Particle Engineering (SPERU), Swiss Federal Institute of Technology, Lausanne, Switzerland; Prof. Joydeep Dutta, Vice President for Academic Affairs (AIT) and Prof. Gabor (Louis) Hornyak of AIT participated in this forum. The Center of Excellence in Nanotechnology was actively involved in designing and conceptualizing the Nanotechnology Pavilion at National Science and Technology Fair 2010 being held until 22 August 2010 at Bangkok International Trade and Exhibition Center (BITEC), Bang-na, Bangkok. Fundamentals of Nanotechnology a publication co-authored by Professor Gabor L. Hornyak and Professor Joydeep Dutta, has been acclaimed as one of the world's Outstanding Academic Titles for 2009 by "Choice: Current Reviews for Academic Libraries", a publication of the Association of College and Research Libraries, and a Division of the

American Library Association. The Outstanding Academic Title list includes 652 books and electric resources chosen by Choice editorial staff from among the 7,065 titles reviewed during the previous year. The outstanding works were selected for their excellence in scholarship and presentation, the significance of their contribution to the field, and their value as important – often the first – treatment of the subject. The list appears in the January 2010 issue of Choice Magazine.

4.7.3 Faculty and Research Staff

Full-time Faculty

JOYDEEP DUTTA, B.Sc. (Hons), St. Edmund's College; MSc (Physics), North Eastern Hill Univ; PhD, Indian Association for the Cultivation of Science, Calcutta Univ, India.

Professor[*Functional materials, nanomaterials, Nanoparticles, self-organisation, Biomimetic processes, Polyelectrolyte deposition, Gas sensors, Bio-sensors, optoelectronic devices*]

Associated Faculty and Research Staff

MOUSA M NAZHAD, BSc, Univ of Concordia, Montreal, Canada; MSc, Univ of Concordia, Montreal; PhD, Univ of British Columbia, Vancouver, Canada.

Associate Professor, Pulp & Paper Technology Field of Study (*Recycled fiber, Paper and Paperboard quality, Nanoparticles in papermaking, Specialty papers, Pulp processing and Bio-refining*)

OLEG V SHIPIN, PhD, Inst of Biochemistry and Physiology of Microorganisms, Moscow, Russia.

Associate Professor, Environmental Engineering & Management Field of Study (*Anaerobic and Aerobic Wastewater Treatment;*

Environmental Impact Assessment; Microbial biotechnology (production of commercially important metabolites); Natural systems (ponds and wetlands) as Wastewater treatment systems; Microbial aspects of Environmental Engineering;Molecular Microbiology, Health and Ecological Risk assessment, Ecological Engineering)

ANIL KUMAR ANAL, DVM., University of Agriculture, Pakistan; MSc. and PhD., AIT, Thailand

Assistant Professor, Food Engineering & Bioprocess Technology Field of Study (*Animal Biotechnology, Food and Pharmaceutical Biotechnology, Dairy and Meat Process Technology, Food Colloids and Biopolymer, Functional Foods, Micro-/Nanoencapsulation, Bionanotechnology*)

PRABHAT KUMAR, Dr.-Rer.Hort., Uni Hannover, Germany; M.Sc. (Ag. Systems), AIT, Thailand; B.Sc. (Ag.) & Hons. RAU, Pusa, India

Affiliated faculty & Senior Research Specialist, Agricultural Systems & Engineering Field of Study (*Integrated Pest Management, Farming Systems, Climate change adaptation, Tropical Plant Production and Protection, Smallholder production, Applied research, Nanotechnology and agriculture*)

Visiting Faculty

GABOR LOUIS HORNYAK, Ph.D. (1997), Colorado State University. Instructor (Introduction to Nanoscience) and Research Professor, Department of Metallurgical & Materials Engineering, Colorado School of Mines in Golden, Colorado

Visiting Faculty [*Span carbon nanotube synthesis & thermodynamics, nano metal*

composite materials fabrication and optical properties, template synthesis of gold-55 quantum dot cluster synthesis & optical characterization]

AKE FALDT, Ph.D. (Physics) (1980), Chalmers University of Technology/University of Gothenburg. Professor of Chalmers University of Technology.

Visiting Professor [General Physics courses, Covering Mechanics, Thermodynamics, Electric and Magnetic fields, Wave Physics, Quantum Physics and Introductory Solid State Physics]

PARIMAL AMARATLAL PARIKH, Ph.D. (1993) M.S. University of Baroda, India

Visiting Professor (Catalytic processes involved in carious conversations in biofuels, e.g. hydrodeoxygenation of fast pyrolysis oils, algae oils, etc. catalytic cracking of used vegetable oils).

FRANCISCO MIGUEL PORTELA DA GAMA, Ph.D. (1996) in Biological Engineering, Universidade do Minho, Portugal.

Visiting Faculty (Enzymatic technology, Controlled Drug Delivery. Biomaterials, Nanobiotechnology, Tissue Engineering).

SIDDHARTH JABADE, Ph.D. (2005) in Mechanical Engineering, Indian Institute of Technology-Bombay, India.

Visiting Faculty (Intellectual property rights, Innovation management, heat transfer).

Adjunct Faculty

CHANCHANA THANACHAYANONT, Ph. D. (1999) and BE (1994), Imperial College, London; The National Metals and Materials Technology Center, National Science and Technology Development Agency, Thailand

Adjunct Faculty (Transmission Electron Microscopy, Materials Characterization, Semiconductor Physics, III-V Compound Semiconductors)

Dr. Waleed S. Mohammed, Ph. D. (2004), University of Central Florida (USA), M. Eng (1999) Cairo University, Egypt; Chulalongkorn University, Bangkok, Thailand

Adjunct Faculty (Optical wireless, Micro/nano optics, Fiber optics, Grating design, Bio-Photonics)

4.7.4 Grants and Sponsored Research Completed in 2010

Lab to large scale dye sensitized solar cells

Duration: 15 Apr 09 -31 Dec 10
Project Investigator(s): Joydeep Dutta
Sponsor: RTG/SVI Public co.Ltd
Total Contracted Amount (THB): 2,000,000

4.7.5 On-going Grants and Sponsored Research

Flow Modeling in Hard disc Drives

Duration: 15 Dec 09 - 31 Dec 11
Project Investigator(s): Joydeep Dutta, Huynh Trung Luong, Pisut Koomsap
Sponsor: Donaldson Company Thailand
Total Contracted Amount (THB): 1,000,000

Nanotechnology Center of Excellence (COE), NANOTEC, NSTDA & Royal Thai Govt. – AIT project

Duration: 2006-2011
Total Contracted Amount: 25 Million Baht
The Center of Excellence In Nanotechnology (CoEN) supported jointly by the National Nanotechnology Center (NANOTEC) of the National Science and Technology Development Agency (NSTDA) of Thailand and the Asian Institute of technology (AIT). The center's researchers carry out cutting-edge cross-disciplinary research. The CoE supports innovative research suited to the region, education and training of highly qualified personnel and in increasing public and industrial awareness of nanotechnology, amongst other activities like arranging conferences, workshops etc.

Photocatalytic thin film coating technology

Duration: 16 Jun 08 - 31 Dec 11

Project Investigator(s): Joydeep Dutta
Sponsor: National Electronic and Computer Technology Center, National Science and Technology Development Agency, Thailand
Total Contracted Amount (THB): 1,870,940

Printed Electronics using Direct Writing Technology

Duration: 08 Mar 05 - 31 Dec 11
Project Investigator(s): Joydeep Dutta
Sponsor: NSTDA
Total Contracted Amount (THB): 2,498,776

Zinc Oxide nanorods as filtration Media for multifunctional applications

Duration: 15 Dec 09 - 31 Dec 11
Project Investigator(s): Joydeep Dutta
Sponsor: Donaldson Company Thailand
Total Contracted Amount (THB): 1,000,000

4.7.6 Publications

Book Chapter

Nanoparticle Applications for Environmental Control and Remediation. S. Baruah, R. Kitsomboonloha, Myo Tay Zar Myint and J. Dutta. Nanoparticles: Synthesis, Characterization and Applications. Edited by R.S. Chaugule and R.V. Ramanujan. American Scientific Publishers (2010), Chapter 7, pages 195-216

International Journal Articles with Impact factor

Abhinandan Makhal, Soumik Sarkar, Samir Pal, Sunandan Baruah, Joydeep Dutta, Tanujjal Bora, and Arup Kumar Raychaudhari. Role of Resonance Energy Transfer in Light Harvesting of Zinc Oxide based Dye Sensitized Solar Cells. Journal of Physical Chemistry C, 114 (2010) 10390–10395. [JCR 2009 Impact Factor ~ 4.224]

Abhinandan Makhal, Soumik Sarkar, Tanujjal Bora, Sunandan Baruah, Joydeep Dutta, A. K. Raychaudhuri and Samir Kumar Pal. Dynamics of Light Harvesting in ZnO Nano-Crystals. Nanotechnology 21 (2010) 265703. [JCR 2009 Impact Factor ~ 3.137]

Alfredo J. Anceno, Ichinkhorloo Bonduush, Oleg V. Shipin, and Joydeep Dutta. Nanoparticle Self-assembly via Facile (Bio)chemistry: chitosan mediated gold nanoparticles on microbial templates. *Journal of NanoBioScience*, 4 (2010) 1–6

S. Baruah, M. A. Mahmood, M. T. Z. Myint, T. Bora and J. Dutta. Enhanced visible light photocatalysis through fast crystallization of zinc oxide nanorods. *Beilstein Journal of Nanotechnology* 1 (2010) 14–20

S. Baruah, M. Jaisai, R. Imani, M. N. Nazhad & J. Dutta. Photocatalytic paper using zinc oxide nanorods. *Science and Technology of Advanced Materials* 11 (2010) 055002. [JCR 2009 Impact Factor ~ 2.599]

Sujira Promnimit, Muhammad Irfan Abid and Joydeep Dutta. Thin Film Multilayers and Its Properties by Self-Organization of Nanoparticles. *Journal of Nano Research Vol. 11* (2010) pp 1-6

Conference Publications

Aarthy Sivapunniam, Myo Tay Zar Myint, Niti Wiromrat and Joydeep Dutta. Liquefied Petroleum Gas Detection Using Zinc Oxide Nanostructures. Proceedings of the "NanoThailand 2010: Nanotechnology for a Sustainable World", Pathumthani, Thailand, November 18-20, 2010, Page 279-282

Chamaiporn Teerasetsoon, Sivanappan Kumar and Joydeep Dutta. Ultrasonic Spray Pyrolysis Preparation of Dye-Sensitized Solar Cells Photoelectrode. Proceedings of the Second Annual International Workshop on Advanced Materials (IWAM 2010), February 21-23, 2010, Ras Al-Khaimah, UAE, Page 64

G.L. Hornyak. Undergraduate and Graduate Education for Emerging Technologies. Proceedings of the

International Conference on Green Energy Technologies: Challenges in Research and Human Resources Development, March 23-25, 2010, Pondicherry, India, Page 57

Htet Htet Kyaw, Tanujjal Bora and Joydeep Dutta. Electrical Modelling of ZnO Nanorod Based Dye Sensitized Solar Cell: Effect of Annealing Temperature. Proceedings of the "NanoThailand 2010: Nanotechnology for a Sustainable World", Pathumthani, Thailand, November 18-20, 2010, Page 166-169

Joydeep Dutta. Zinc Oxide Nanostructures for Green Technology. Proceedings of the Second Annual International Workshop on Advanced Materials (IWAM 2010), February 21-23, 2010, Ras Al-Khaimah, UAE, Page 35

Joydeep Dutta. ZnO Nanostructures: Environmental Remediation and Energy Generation. Proceedings of the International Conference on Green Energy Technologies: Challenges in Research and Human Resources Development, March 23-25, 2010, Pondicherry, India, Page 17

Mayur B. Chaudhari, Saabah Bin Mahbub, Waleed S. Mohammed, G.L. Hornyak and Joydeep Dutta. Study of Optical Properties of Metal Nano-Particles with Oxide Host Medium. Abstract of the "NanoThailand 2010: Nanotechnology for a Sustainable World", Pathumthani, Thailand, November 18-20, 2010, Page 1

Mayuree Jaisai, Sunandan Baruah, Reza Imani, Mousa M. Nazhad and Joydeep Dutta. Antimicrobial Paper with ZnO Nanorods. Abstract of the "NanoThailand 2010: Nanotechnology for a Sustainable World", Pathumthani, Thailand, November 18-20, 2010, Page 138-139

Mohammad Abbas Mahmood and Joydeep Dutta. Seeding Through Spray Pyrolysis for the Subsequent

Growth of Zinc Oxide Nanorods on Glass Substrates. Proceedings of the "NanoThailand 2010: Nanotechnology for a Sustainable World", Pathumthani, Thailand, November 18-20, 2010, Page 97-100

Muhammad Irfan Abid, Sujira Promnimit and Joydeep Dutta. Electronic Devices Fabricated by Layer by Layer Self Assembly of Colloidal Nanoparticles. Proceedings of the 7th International Bhurban Conference on Applied Sciences & Technology, January 11 – 14, 2010, Islamabad, Pakistan, Page 29-33

Myo Tay Zar Myint and Joydeep Dutta. Zinc Oxide Microrods Coated Superhydrophobic Cotton Fabric. Proceedings of the Thailand Textile Symposium 2010, Miracle Grand Convention Hotel, Bangkok, Thailand, August 26, 2010, Page 39-40

Myo Tay Zar Myint, Pattamon Teerapanich, G.L. Hornyak and Joydeep Dutta. Fabrication of Anodic Alumina Nanoporous Membrane with Oxalic Acid Electrolyte. Proceedings of the "NanoThailand 2010: Nanotechnology for a Sustainable World", Pathumthani, Thailand, November 18-20, 2010, Page 93-96

Myo Tay Zar Myint, Rungrot Kitsomboonloha, Sunandan Baruah and Joydeep Dutta. Superhydrophobic Surfaces by Hierarchical Zinc Oxide Micro Rod Patterned Surface Arrays. Proceedings of the Second Annual International Workshop on Advanced Materials (IWAM 2010), February 21-23, 2010, Ras Al-Khaimah, UAE, Page 129

P. Boonyanitipong, B. Kositsup, J. Dutta and P. Kumar. Effect of nanoparticles on Rice (*Oryza sativa* L.) Seed Germination and Root Elongation. Abstracts of the "15th Biological Sciences Graduate Congress: Bridging Ideas, Building Talents", University of Malaya, Kuala

Lumpur, Malaysia, December 15-17, 2010, Page 176

Sunandan Baruah and Joydeep Dutta. Activity of Zinc Oxide Nanorods for Visible Light Photocatalysis. Proceedings of the Second Annual International Workshop on Advanced Materials (IWAM 2010), February 21-23, 2010, Ras Al-Khaimah, UAE, Page 117

Sunandan Baruah, Mayuree Jaisai, Reza Imani, Mousa M. Nazhad and Joydeep Dutta. ZnO Nanorods on Cellulose: Photocatalytic Properties. Proceedings of the "NanoThailand 2010: Nanotechnology for a Sustainable World", Pathumthani, Thailand, November 18-20, 2010, Page 170-173

Supamas Danwittayakul and Joydeep Dutta. Hydrogen Production Using Zinc Oxide Nanorods Supported Catalyst. Abstract of the "NanoThailand 2010: Nanotechnology for a Sustainable World", Pathumthani, Thailand, November 18-20, 2010, Page 134-135

Supaporn Leungsuree and Joydeep Dutta. Anisotropic Zinc Oxide

Nanoparticles: Hydrothermal Synthesis. Proceedings of the Second Annual International Workshop on Advanced Materials (IWAM 2010), February 21-23, 2010, Ras Al-Khaimah, UAE, Page 130

Supaporn Leungsuree, Sunandan Baruah and Joydeep Dutta. Anisotropic Growth of ZnO Nanoparticles. Abstract of the "NanoThailand 2010: Nanotechnology for a Sustainable World", Pathumthani, Thailand, November 18-20, 2010, Page 257-258

Tanujjal Bora, Htet Htet Kyaw and Joydeep Dutta. ZnO/Au Schottky Junction Dye Sensitized Solar Cell: Improved Efficiency. Proceedings of the "NanoThailand 2010: Nanotechnology for a Sustainable World", Pathumthani, Thailand, November 18-20, 2010, Page 135-138

Tanujjal Bora, Htet Htet Kyaw, Mana Poyai and Joydeep Dutta. Improved ZnO Nanorod Dye-Sensitized Solar Cell Efficiency through Better Charge Separation by Gold Nanoparticles. Proceedings of the Second Annual International Workshop on

Advanced Materials (IWAM 2010), February 21-23, 2010, Ras Al-Khaimah, UAE, Page 65

Zaheer Abbas Khan, Rachana Kumar, Waleed S. Mohammed, G.L. Hornyak and Joydeep Dutta. Multilayer Thin Films of Colloidal Gold and Silica Nanoparticles-Effect of Polyelectrolyte Coating. Proceedings of the "NanoThailand 2010: Nanotechnology for a Sustainable World", Pathumthani, Thailand, November 18-20, 2010, Page 81-84

Zaheer Abbas Khan, Rachana Kumar, Waleed S. Mohammed, G.L. Hornyak and Joydeep Dutta. Maxwell-Garnett (M-G) Theory Simulations of Alternating Gold-Silica Colloidal Multilayer Thin Film Composites. Proceedings of the "NanoThailand 2010: Nanotechnology for a Sustainable World", Pathumthani, Thailand, November 18-20, 2010, Page 108-110

4.8: SET – REMOTE SENSING AND GEOGRAPHIC INFORMATION SYSTEMS FIELD OF STUDY

4.8.1 Introduction

Geoinformatics comprising Remote Sensing (RS), Geographic Information Systems (GIS) and Global Positioning System (GPS) provides extremely useful tools for environmental and natural resources management. They are widely recognized as supporting tools for the planning, monitoring, and management of the appropriate utilization of resources at the country, regional and global levels.

While they represent multidisciplinary backgrounds, students in RS&GIS share a common interest, that is, to use remote sensing, GIS, GPS and other space technologies as tools in pursuing their academic work as well as in developing new technologies that are applicable to the region. Because of the complexity of the technologies together with the heavy dependence on advanced computer skills, application specialists need to have a sound knowledge of the theoretical aspects and practical approaches to integrate many resources of information that address different applications.

Furthermore, scientists, planners or engineers interested in these technologies should be familiar with past, present and future satellite systems, their appropriate usage, data acquisition and handling and integration with other data sources.

The curriculum well covers the theoretical aspects and application of space technology, especially in Remote Sensing and GIS. It provides students ample time to gain application know-how through laboratory sessions. Students are free to use satellite data received by the NOAA, AVHRR and MODIS Satellite Receiving Stations for their theses or research studies. Recently such as open source Geoinformatics climate change Monitoring using courses Geoinformatics, Advanced Application

Development Advance Analysis Methods and Microwave Remote Sensing are add.

The demand for RS&GIS graduates is very high as there is lack of professionals in these disciplines, particularly those with a vast knowledge of the practical utilization of these technologies. Employment opportunities are available in a wide range of areas, including agriculture, forestry, coastal development and management, urban planning and development, medical technology, mapping and planning, disaster mitigation and environmental management.

Major areas covered in the coursework are fundamentals of remote sensing and GIS, earth energy interaction, atmospheric correction, application potential in various disciplines, GIS data sources, map projection, geostatistics, spatial modeling, automated mapping, digital terrain model, GPS data acquisition, and integration of GIS, remote sensing and GPS.

4.8.2 Research Facilities and Laboratories

The RS&GIS field of study provides excellent facilities for learning, research and projects which consists of the Digital Image Processing laboratory, Institute-wide GIS laboratory, Asia e-learning project experiment room, meeting rooms, and the Geoinformatics Center laboratory. The RS&GIS field of study has a policy of maintaining the best working environment for students, staff and faculty.

The RS&GIS LAN Network can also be monitored in real time. Besides, it has a very good archive of satellite imagery of SPOT, Landsat-TM, MODIS, NOAA, ADEOS, ERSSAR, and JERS-SAR to serve the students in their research and thesis studies. Other data, such as topographic,

landuse, soil, geology maps of Thailand and some aerial photographs, ALOS data, are also available. The RS&GIS library also provides students with more specialized books, journals, and computer manuals. Some of the technical magazines regularly available are GIM International, GIS@Development, and International Journal of Geoinformatics.

Some equipment in its laboratory available for academic activities include: Arc GIS 9.4, ERDAS, Arc View 3.3, ENVI; Total Station; Trimble geoexplorer; Garmin GPS Series III and V; digital camera; wireless hub/switch; wireless USB; network switch; network hub; black/white and color laser printers; A4 and A0 scanners; RFID reader/writer, Sensors and Wi Fi Network, Spectrophotometer, Laser Range Finder, Echo Sounder, Sensor Web GIS; table and personal stereoscopes, SCINDA GPS Base Station, TOPCON Photogrammetry Station and others.

4.8.3 Faculty and Research Staff

Full-time Faculty

KIYOSHI HONDA, BAg, DEng, University of Tokyo, Japan
Associate Professor (*Image Processing, Erosion control, Terrain modeling, Sensor Web GIS*)

NITIN KUMAR TRIPATHI, BTech, National Institute of Technology, Warangal, India; MTech, IIT; PhD, IIT, Kanpur, India.

Associate Professor (*GIS, Remote Sensing, RFID and Vehicle Tracking, Indoor Positioning Systems, Environment, Disaster, Agriculture, Health, Applications*)

Visiting Faculty

MARC SOURIS, PhD, Université de La Rochelle, France

Visiting Professor

(Computational geometry and algorithms, GIS development, Spatial analysis, GIS and Remote Sensing for Epidemiology)

MICHIRO KUSANAGI, BS, MS, Univ of Tokyo, Japan; MS, Ph.D, Univ of California, USA.

Visiting Professor (Aerospace System Engineering, Space System Engineering)

YOSHIKAZU KAMIYA, BEng, Yokohama National University, Japan; MEng, Ph.D. University of Tokyo, Japan

Visiting Faculty (Aerospace System Engineering and Microwave Remote Sensing)

MASAHIKO NAGAI, BS, St. Cloud State University, USA; MS, Asian Institute of Technology, Thailand; DEng, The University of Tokyo, Japan

Visiting Faculty (Spatial Information Engineering, Remote Sensing, GIS, Image Processing, Mobile Mapping Ontology, Data Interoperability, Environmental Information Science)

Adjunct Faculty

I.V. MURALI KRISHNA, MTECH, Indian Institute of Technology, India; Ph.D., Indian Institute of Science, India.

Adjunct Professor (Remote Sensing Applications in Environment, Climate Change, Sustainable Development)

SURAT LERTLUM, BS, Norwich University; MS, The George Washington University, USA; DTechSc Computer Science, Asian Institute of Technology, Thailand

Adjunct Faculty (GIS, RS, Digital Image Processing, Surveying, Mapping)

VENKATESH RAGHAVAN, BS, MS, Univ of Poona, India; Ph.D., Univ. of Osaka City, Japan

Adjunct Faculty (Spatial Information Science and Geoinformatics)

Affiliated Faculty and Research Staff

LAL SAMARAKOON, PhD

Visiting Senior Scientist; Director, GIC (GIS, RS, Digital Image Processing, Surveying, Mapping)

MANZUL KUMAR HAZARIKA, PhD, University of Tokyo, Japan; MEng, Asian Institute of Technology, Bangkok, Thailand; MTech, Indian Institute of Technology, Kharagpur; BTech, J N KrishiVishwaVidyalaya (J. N. Agriculture University), India

Senior Research and Training Specialist (RS and GIS Applications to Global Environment, Terrestrial Carbon Cycle and NPP)

TARAVUDH TIPDECHO, BSc, MSc, Chiangmai Univ, Thailand; DTechSc, Remote Sensing & GIS, Asian Institute of Technology, Thailand

Research Specialist I (Advanced Mapping, Terrestrial Scanning)

VIVARAD PHONEKEO, Bsc, Volgograd State Pedagogical University, Russia, MSc, DTechSc, Asian Institute of Technology, Thailand

Senior Research Associate (Remote Sensing and GIS, [NOAA AVHRR&Terra/Aqua MODIS receiving and processing system](#), Digital Image Processing, Computer Graphics, Spatial Data Visualization, MODIS Active Fire Monitoring System, Global Environment and Disaster Monitoring using MODIS)

4.8.4 Grants and Sponsored Research Completed in 2010

International Conference on Health GIS

Duration: 01 Oct 07 -30 Apr 10
Project Investigator(s): Nitin Kumar Tripathi
Sponsor: Self-paid
Total Contracted Amount (THB): 360,000

Orthorectification of High Resolution Satellite Data

Duration: 24 Nov 08 -30 Jun 10
Project Investigator(s): Nitin Kumar Tripathi
Sponsor: Multi donors
Total Contracted Amount (THB): 284,458

Sensor Net Visualization 2007

Duration: 13 Aug 07 -31 May 10
Project Investigator(s): Honda Kiyoshi
Sponsor: Elabo Experience Company Limited
Total Contracted Amount (THB): 3,042,000

4.8.5 On-going Grants and Sponsored Research

Business and Logistics Management using Integrated RFID and Internet GIS

Duration: 01 Aug 07 - 30 Jun 11
Project Investigator(s): Nitin Kumar Tripathi
Sponsor: RTG/CARACAD
Total Contracted Amount (THB): 1,800,000

Data generation for Tsunami modeling and Risk assessment

Duration: 01 Oct 09 - 31 Dec 11
Project Investigator(s): Kiyoshi Honda
Sponsor: Asian Disaster Preparedness Center (ADPC)
Total Contracted Amount (THB): 4,947,360

Integrated Coastal Zone Planning and Management using Geoinformation Technology

Duration: 01 Nov 09 - 30 Jun 11
Project Investigator(s): Nitin Kumar Tripathi
Sponsor: Multi donors
Total Contracted Amount (THB): 544,000

Integrated Coastal Zone Planning and Management Using RS and GIS

Duration: 15 Sep 08 - 30 Jun 11
Project Investigator(s): Nitin Kumar Tripathi
Sponsor: Self-paid
Total Contracted Amount (THB): 1,257,450

**Provision of Galileo expertise
Networking and Support for
International Initiatives**

Duration: 01 Nov 08 - 30 Jun 11
Project Investigator(s): Nitin Kumar Tripathi
Sponsor: Instituto Superiore Mario Boella, Italy
Total Contracted Amount (THB): 687,000

**South East Asia Center on European
GNSS for International cooperation and
Local development.**

Duration: 15 Mar 09 - 30 Jun 11
Project Investigator(s): Nitin Kumar Tripathi
Sponsor: The European GNSS Supervisory Authority
Total Contracted Amount (THB): 1,996,000

**Thailand GIS Development for Research
on Ontology**

Duration: 01 Jan 08 - 20 Dec 13
Project Investigator(s): Lal Samarakoon
Sponsor: Center for Spatial Information Science,
University of Tokyo
Total Contracted Amount (THB): 1,050,000

**The Application of GPU Computing
technology to accelerate Geoinformatics
Applications**

Duration: 31 Jul 09 - 28 Feb 11
Project Investigator(s): Kiyoshi Honda
Sponsor: RTG
Total Contracted Amount (THB): 990,000

**UNIGIS Online Masters and Professional
Program**

Duration: 01 Aug 07 - 31 Dec 11
Project Investigator(s): Nitin Kumar Tripathi
Sponsor: Self-paid
Total Contracted Amount (THB): 1,089,000

4.8.6 Publications

**International Journal Articles with
Impact factor**

Canisius F., Kiyoshi Honda, Tokunaga M.. Updating geomorphic features of watersheds and their boundaries in hazardous areas using satellite synthetic aperture radar. *International Journal of Remote Sensing*, 22(30) 0-0, 2010.

Chaikaew N., Nitin K. Tripathi, Marc Souris. Exploring spatial patterns and hotspots of diarrhea in Chiang Mai, Thailand. *International Journal of Health Geographics*, 1(8) 0-0, 2010.

Dammalage T.L., Chalermchon Satirapod, Seishiro Kibe, Ogaja C.. C/A code multipath mitigation at

GPS base stations for improved DGPS corrections using wavelets. *Survey Review*, 317(42) 0-0, 2010.

Diallo M.B.C., Anceno A.J., Tawatsupa B., Nitin K. Tripathi, Voranuch L. Wangsuphachart, Oleg Shipin. GIS-based analysis of the fate of waste-related pathogens *Cryptosporidium parvum*, *Giardia lamblia* and *Escherichia coli* in a tropical canal network. *Journal of Water and Health*, 1(7) 0-0, 2010.

Hossain M.Z., Nitin K. Tripathi. Monitoring near-shore and insular marine protected area network using landsat, ASTER and IKONOS images. *International Journal of Imaging*, 10 S(3) 0-0, 2010.

Hung N.Q., Mukand S. Babel, Sutat Weesakul, Nitin K. Tripathi. An artificial neural network model for rainfall forecasting in Bangkok, Thailand. *Hydrology and Earth System Sciences*, 8(13) 0-0, 2010.

Kiyoshi Honda, Shrestha A., Witayangkurn A., Chinnachodteeranun R., Shimamura H.. Fieldservers and sensor service grid as real-time monitoring infrastructure for ubiquitous sensor networks. *Sensors*, 4(9) 0-0, 2010.

Lek-Uthai U., Sangsayan J., Kachenchart B., Kulpradit K., Sujirarat D., Kiyoshi Honda. Novel ellipsoid spatial analysis for determining malaria risk at the village level. *Acta Tropica*, 1(116) 0-0, 2010.

Mahasandana S., Nitin K. Tripathi, Kiyoshi Honda. Sea surface multispectral index model for estimating chlorophyll a concentration of productive coastal waters in Thailand. *Canadian Journal of Remote Sensing*, 3(35) 0-0, 2010.

Marc Souris, Gonzalez J.-P., Shanmugasundaram J., Corvest V., Kittayapong P.. Retrospective space-time analysis of H5N1 Avian Influenza emergence in Thailand.

International Journal of Health Geographics, (9) 0-0, 2010.

Podchong S., Dietrich Schmidt-Vogt, Kiyoshi Honda. An improved approach for identifying suitable habitat of Sambar Deer (*Cervus unicolor* Kerr) using ecological niche analysis and environmental categorization: Case study at Phu-Khieo Wildlife Sanctuary, Thailand. *Ecological Modelling*, 17(220) 0-0, 2010.

Ramli M.F., Nitin K. Tripathi, Yusof N., Shafri H.Z.M., Rahman Z.A.. Lineament mapping in a tropical environment using Landsat imagery. *International Journal of Remote Sensing*, 23(30) 0-0, 2010.

Shahid S., Manzul Kumar Hazarika. Groundwater drought in the northwestern districts of Bangladesh. *Water Resources Management*, 10(24) 0-0, 2010.

Vansarochana A., Nitin K. Tripathi, Clemente R.. Finding appropriate interpolation techniques for topographic surface generation for mudslide risk zonation. *Geocarto International*, 4(24) 0-0, 2010.

Xiaoyong Chen, Mousa M. Nazhad. How is frayed fiber generated during refining process? (identification of frayed fiber under high resolution microscope). *Journal of Engineered Fibers and Fabrics*, 3(5) 0-0, 2010.

4.8.7 Masters Students' Theses

A Study on the Cause and Effect of Reducing Natural Drainage Channels in Dhaka City

By Rezwana Kaiser
Supervisor: Dr. Kiyoshi Honda

Crop Parameter Estimation for DSSAT Ceres Rice Through a Data Assimilation Technique

By Chudech Losiri
Supervisor: Dr. Kiyoshi Honda

Development of Low Cost Bathymetric Mapping System for Tsunami Inundation Modeling

By J Elaine J. Layug
Supervisor: Dr. Kiyoshi Honda

Estimation of Above Ground Biomass and Carbon Stock Using Remote Sensing: A Case Study in Mondulkiri Forest, Cambodia

By Sar Sophyra
Supervisor: Dr. Nitin K. Tripathi

Integration of SAR, Optical Remote Sensing Data and GIS for Change Detection and Restoration of Nipa Palm Plantation in Pak Phanang, Thailand

By Jannet C. Bencure
Supervisor: Dr. Nitin K. Tripathi

Land Price and Land Suitability Analysis by Integrated GIS and Fuzzy Logic: A Case Study of Housing Site Selection in Thanyaburi District, Pathumthani, Thailand

By Saranchai Pisitbanyong
Supervisor: Dr. Nitin K. Tripathi

Mapping Coastal Landuse and Bathymetry Changes Using Satellite Sensing in Park Phanang Bay, Thailand

By Nithima Nuengjumnong
Supervisor: Dr. Nitin K. Tripathi

Mapping of Hotspots of Atmospheric Carbon Dioxide and Nitrogen Dioxide in Thailand Using Sciamachy

By Uday Pimple
Supervisor: Dr. Nitin K. Tripathi

Mapping of Marine and Ecological Changes in Truong Giang Lagoon, Quang Nam Province, Vietnam

By Phan Kieu Diem
Supervisor: Dr. Nitin K. Tripathi

Near Real Time Traffic Parameter Monitoring

By Prabin Kishor Pury
Supervisor: Dr. Nitin K. Tripathi

Real-Time Air Route Monitoring System Using Sensor Network (Sensor Service GRID) for Efficient Mountain Area Aviation Nepal

By Asamaporn Sitthi
Supervisor: Dr. Kiyoshi Honda

4.9: SET – STRUCTURAL ENGINEERING FIELD OF STUDY

4.9.1 Introduction

Structural engineering has always been seen as one of the few fields of study where one can combine real technical skills with artistic flair. Structural engineers are known to be people who enjoy innovation, opportunities, responsibility and excitement, whilst working within a creative profession. Structural engineers plan and design various structures such as buildings, bridges, sport stadiums, towers, and underground structures.

The built environment which is designed and constructed by structural engineers has an enormous impact on our everyday lives. In order to design and construct safe and economic structures, they need to keep abreast with the latest methods of structural analysis, modeling concepts for computation, advanced design, material technology, and improved knowledge in structural loadings. The field educates professionals who will be at the forefront of advanced research in Structural Engineering. They are trained to respond creatively to the industrial requirements of infrastructure development.

4.9.2 Research Facilities and Laboratories

Structural Engineering Laboratory

The Structural Engineering Laboratory (STE Lab) has a long history of excellence in advanced structural and material research. The STE Lab is equipped with instruments for scientific research, which provide excellent experimental environment for scholars and experts in the Asian region to enhance academic cooperation and development. Completed in 1975 and renovated in 2000, the structural testing area of

the laboratory is a versatile area with a two-storey clear height that can be used to carry out a wide range of tests of building materials, components, structural assemblies and models.

One of principal elements of STE Lab is a strong floor system. The strong floor is a 1.5 meter deep heavily reinforced concrete mat, covering an area of 380 square meters, with anchorage slots spaced 1 meter apart and cluster points with a capacity of 1,000 kN per cluster. This arrangement provides versatility in the mounting of experiments, and full-size members of complete structures can be loaded to destruction. A test control room and the hydraulic power supply area are located adjacent to the test floor. The laboratory is equipped with a series of hydraulic actuators of various load (100 kN to 500 kN.), stroke (+100 mm to +250 mm.) and servo-value capacities for static, dynamic and fatigue testing. Standard laboratory instrumentation for structural engineering is available e.g., extensometer, universal testing machine, ultrasonic pulse velocity and strain gauge preparation, impulse force test hammer, etc.

Seismic Load Simulation Facility

Set up in 2001, the Seismic Load Simulation Facility is basically composed of (1) a rigid, A-shape, steel reaction wall, (2) a 50-ton force generating capacity, 1000-mm piston stroke, hydraulic actuator that operates under precision closed-loop servo value control, and (3) the existing strong reinforced concrete floor of the STE Lab. The facility has the capability to perform various experimental seismic tests on near-full-scale structural models, such as quasi-static tests, cyclic loading tests, and pseudodynamic tests. The facility has been used intensively by

many master and doctoral students in STE Field of Study.

Boundary Layer Wind Tunnel Laboratory

This wind tunnel laboratory is a state-of-the-art research facility for the study of wind loads and several complex wind-induced effects on buildings and structures. The laboratory was developed by a joint effort between School of Engineering and Technology at AIT and Faculty of Engineering at Thammasat University. The laboratory, located in Thammasat, is the longest and largest wind tunnel in Thailand. It is capable of simulating atmospheric boundary layer wind as well as smooth and uniform wind in its 2.5m x 2.5m tunnel section with wind speeds varying from 0.5 m/s to 20 m/s. The wind tunnel is well equipped with hot-wire anemometers, pressure transducers with rotary scanning system, multi-component dynamic force sensors, dynamic motion sensors, turn tables, rotary side frames, and several other instruments. With this facility, various types of advanced experimental research study, student training, and industrial aerodynamic tests can be realized. The construction of the wind tunnel was completed in 2003, and it has been used intensively since then by graduated students of AIT and Thammasat University.

4.9.3 Faculty and Research Staff

Emeritus Professor

PISIDHI KARASUDHI, Ph.D., Northwestern Univ., USA; M.Eng., AIT, Thailand; B.Eng., Chulalongkorn Univ. Thailand. [*Solid Mechanics*]

Full-time Faculty

WORSAK KANOK-NUKULCHAI, Ph.D., Univ of California (Berkeley), USA. ; M.Eng., AIT, Thailand; B.Eng. (Hon), Chulalongkorn Univ, Thailand.

Professor [Computational Mechanics; Finite Element Methods; Tall Building Static and Seismic Analysis; Bridge Engineering; Microcomputer Software for Structural Engineering; Genetic Algorithms; Nonlinear Analysis of Structures and Continua; Plate/Shell Structures; Engineering Education; Nanomechanics]

PENNUNG WARNITCHAI, D.Eng., M.Eng., University of Tokyo, Japan; B.Eng. (Hon), Chulalongkorn Univ, Thailand.

Associate Professor [Structural Dynamics; Earthquake Engineering; Wind Effects of Structures; Bridge Engineering; Control of Structural Vibration]

PUNCHET THAMMARAK, PhD, The Univ of Texas, Austin, USA; B.Eng, Chulalongkorn Univ, Thailand;

Instructor [Finite-Element Analysis (FE Programming); Dynamic problem & Wave Propagation Analysis; Absorbing Boundary Conditions; Material Nonlinearities; Soil-Structure Interactions; Structural Engineering (Reinforced-Concrete Design/Steel Design)]

Visiting/Adjunct/Affiliated Faculty

KI-DU KIM, Ph.D Imperial College of Science Technology and Medicine, England; M.S., AIT, Thailand, B.S., Hanyang, Korea.

Visiting Professor [Development of general purpose nonlinear dynamic finite element software; Large displacement elastoplastic analysis of steel shell structures with initial imperfection; Development of non-linear solid, shell and thin-walled beam element; Postbuckling behavior of un-stiffened and stiffened

composite plate and shell structures using finite element method; Nonlinear analysis of reinforced concrete & prestressed concrete structures; Non-linear dynamic analysis of suspension bridge]

CHING-JONG WANG, Ph.D. University of Arizona, USA; M.S. Wayne State University USA; B.S. National Central University, Taiwan.

Visiting Faculty [Seismic performance assessment for bridge structures; Developed procedures and application computer codes for equivalent SDOF- Capacity spectrum method; Equivalent SDOF – Nonlinear dynamic analysis Multi-span bridge frame model – Nonlinear static pushover analysis; Finite element soil-structure dynamic interaction; Developed modeling and analysis computer codes for underground MRT box structure racking analysis; Multi-span bridge deck pounding analysis Flood flow resistance of bridge structures; Impact response of underground conduits]

THANAKORN PHEERAPHAN, Ph.D. and M.Sc., Massachusetts Institute of Technology, USA. B.Sc., Virginia Military Institute, USA.

Adjunct Assistant Professor [Dynamic soil-structure interaction; Seismic behavior of under ground structure; Seismic behavior of earth structure; Multi-Agent simulation; Development of Virtual Clearinghouse for earthquake disaster reconnaissance]

RAKTIPONG SAHAMITMONGKOL, D.Eng., M.Eng, University of Tokyo, Japan; B.Eng., Sirindhorn International Institute of Technology, Thailand.

Adjunct Faculty [Cracking Resistance of Expansive Concrete; Chemically Prestressed Concrete; Inspection on Concrete Structures & Performance Based

Design; Non-Destructive Testing for Concrete Structures; Tension Stiffening Effect and Bonding Characteristic of Reinforced Concrete]

SONGKIAT MATUPAYONT, Ph.D., Saitama University, Japan; M.Eng., AIT, Thailand; B.Eng., Chulalongkorn Univ, Thailand.

Adjunct Faculty [Bridge Engineering; Prestressed Concrete; Structural Analysis and Design]

KITTIPOOM RODSIN, Ph.D., The University of Melbourne, Australia; M.Eng., AIT, Thailand; B.Eng., Chulalongkorn Univ, Thailand.

Adjunct Faculty [Experimental Investigation of Socket-Type Connection for Pre-Cast Column-Footing Connection; Suppression of Pedestrian Bridge Vibration in Bangkok]

BUI THANH TAM, D.Eng., M.Eng., AIT, Thailand; B.Eng., HoChiMinh City University of Technology, Vietnam.

Affiliated Faculty and Research Engineer [Computational Mechanics; Finite Element Analysis; Structural Analysis; Fluid-Structure Interaction; Parallel Computing; Software Development]

NAVEED ANWAR, D.Eng., M.Eng., AIT, Thailand; B.Sc.Eng., Univ. of Engineering & Tech., Lahore, Pakistan.

Affiliated Faculty [Structural Analysis and Design; Computational Mechanics; Computer Application; Bridge Engineering; Tall Buildings; Software Development]

SUN SAYAMIPUK, D.Eng., M.Eng., AIT, Thailand; B.Eng., Kasetsart Univ., Thailand.

Affiliated Faculty and Senior Laboratory Supervisor [Low cost housing materials, Construction materials and its durability, Supplementary cementitious materials, Experimental

*behavior of structural systems,
Field testing of structures]*

4.9.4 Grants and Sponsored Research Completed in 2010

Collapse Modelling of Soft Storey Building

Duration: 15 Nov 08 -31 Dec 10
Project Investigator(s): Pennung Warnitchai
Sponsor: RTG
Total Contracted Amount (THB): 957,500

Evaluation on the Quantity of Incomplete House Construction for the Bann-Eur Arthorn Project

Duration: 15 Jan 10 -30 Jun 10
Project Investigator(s): Sun Sayamipuk
Sponsor: National Housing Authority, Thailand
Total Contracted Amount (THB): 3,400,000

Independent Inspecting and Testing Agency for Concrete Sleeper Manufacturing

Duration: 01 Jan 10 -30 May 10
Project Investigator(s): Sun Sayamipuk
Sponsor: Star Rail Co Ltd
Total Contracted Amount (THB): 280,000

Master Plan for Earthquake Mitigation in Thailand Phase II

Duration: 15 Nov 09 -31 Dec 10
Project Investigator(s): Pennung Warnitchai
Sponsor: Panya Consultants Co., Ltd.
Total Contracted Amount (THB): 1,568,000

Seismic Retrofitting of Existing Buildings in Thailand

Duration: 01 Apr 08 - 31 Dec 10
Project Investigator(s): Pennung Warnitchai
Sponsor: ADPC
Total Contracted Amount (THB): 4,299,700

Seismic Vulnerability and Risk Assessment of Dhaka, Chittagong and Sylhet City Corporation Areas

Duration: 01 Jun 08 -31 Dec 10
Project Investigator(s): Pennung Warnitchai, Kawin Worakanchana
Sponsor: Asian Disaster Preparedness Center (ADPC)
Total Contracted Amount (THB): 4,299,700

4.9.5 On-going Grants and Sponsored Research

Development of Seismic Design Code for Buildings and Structures in Thailand

Duration: 19 Sep 07 - 28 Feb 11
Project Investigator(s): Pennung Warnitchai
Sponsor: Siridhorn Institute of Technology (SIIT)
Total Contracted Amount (THB): 2,380,000

Master Plan for Earthquake Disaster Mitigation in Thailand

Duration: 15 Nov 09 - 30 Apr 11
Project Investigator(s): Pennung Warnitchai
Sponsor: Panya Consultants Co.,Ltd.
Total Contracted Amount (THB): 1,568,000

Mix design of RCC for Upper Pandas Hydropower

Duration: 01 Sep 09 - 30 Aug 12
Project Investigator(s): Sun Sayamipuk
Sponsor: Upper Pandas Hydropower Consultants
Total Contracted Amount (THB): 2,006,400

Seismic Retrofitting of Existing Buildings in Thailand

Duration: 01 Apr 08 - 28 Feb 11
Project Investigator(s): Pennung Warnitchai
Sponsor: The Thailand Research Fund
Total Contracted Amount (THB): 3,850,000

Structural Evaluation of Vortex Shedding Effect on Pelletizer Structure

Duration: 01 Jun 09 - 30 Jun 11
Project Investigator(s): Pennung Warnitchai/Dr. Naveed Anwar
Sponsor: Toyo-Thai Corporation Public Company Limited
Total Contracted Amount (THB): 650,000

Structural Integrity Evaluation of the Burapa Withi Expressway

Duration: 01 Jun 10 - 30 Nov 11
Project Investigator(s): Pennung Warnitchai
Sponsor: Expressway Authority of Thailand
Total Contracted Amount (THB): 26,980,000

4.9.6 Publications

International Journal Articles with Impact factor

Dinh V.N., Kidu Kim, Pennung Warnitchai. Dynamic analysis of three-dimensional bridge-high-speed train interactions using a wheel-rail contact model. *Engineering Structures*, 12(31) 0-0, 2010.

Djoensan Santoso, Tsunokawa K.. Comparison of updating techniques in transferability analysis of work trip mode choice models in developing countries. *Journal of Advanced Transportation*, 2(44) 0-0, 2010.

Greepala V., Pichai Nimityongskul. Influence of heating envelope on structural fire integrity of ferrocement jackets. *Fire Technology*, 4(45) 385-404, 2009.

Litsomboon T., Pichai Nimityongskul, Naveed Anwar. Development of lightweight aggregate concrete containing pulverized fly ash and bottom ash. *Key Engineering Materials*, (400-402) 379-384, 2009.

Nguyen D.-V., Kidu Kim, Pennung Warnitchai. Simulation procedure for vehicle-substructure dynamic interactions and wheel movements using linearized wheel-rail interfaces. *Finite Elements in Analysis and Design*, 5(45) 0-0, 2010.

Ornthammarath, T., Warnitchai, P., Worakanchana, K., Zaman S., Sigbjörnsson, R., and Carlo Giovanni Lai (2010), "Probabilistic Seismic Hazard Assessment of Thailand", *Bulletin of Earthquake Engineering*, Online First - 3rd August 2010.

Parichatprecha R., Pichai Nimityongskul. An integrated approach for optimum design of HPC mix proportion using genetic algorithm and artificial neural networks. *Computers and Concrete*, 3(6) 253-268, 2009.

Parichatprecha R., Pichai Nimityongskul. Analysis of durability of high performance concrete using artificial neural networks. *Construction and Building Materials*, 2(23) 0-0, 2010.

Pennung Warnitchai, Sinthuwong S., Poemsantitham K.. Wind tunnel model tests of large billboards. *Advances in Structural Engineering*, 1(12) 0-0, 2010.

Phansiri, B., Park, K. H. and Warnitchai, P. (2010), "A BEM Formulation for Inelastic Transient Dynamic Analysis using Domain Decomposition and Particular Integrals", *Computational Mechanics* (Article in press).

Pimanmas, A., Joyklad, P., and Warnitchai, P. (2010), "Structural Design Guideline for Tsunami Evacuation Shelter", *Journal of Earthquake and Tsunami*, Vol. 4, Issue 4, December 2010, pp. 269-284.

Rajapakse N., Chau K.T., Wijeyewickrema A.C., Worsak Kanok-Nukulchai. *Advances in Structural Engineering: Preface*. *Advances in Structural Engineering*, 1(12) 1-1, 2009.

Sinthaworn S., Pichai Nimityongskul. Quick monitoring of pozzolanic reactivity of waste ashes. *Waste Management*, 5(29) 1526-1531, 2009.

Wong F.T., Worsak Kanok-Nukulchai. On the convergence of the kriging-based finite element method. *International Journal of Computational Methods*, 1(6) 0-0, 2010.

Worsak Kanok-Nukulchai, Vimuktayon V.. Suvarnabhumi airport, Thailand. *Structural Engineering International: Journal of the International Association for Bridge and Structural Engineering (IABSE)*, 1(19) 0-0, 2010.

4.9.7 Doctoral Students' Dissertation

Experimental and Numerical Seismic Analysis of Concrete Gravity Dam and Development of BEM for Nonlinear Dynamic Analysis
By Bupavech Phansiri
Supervisor: Dr. Kyung-Ho Park

Kriging-Based Finite Element in Method for Material Discontinuities and Multiscale Simulation
By Wichain Sommanawat
Supervisor: Prof. Worsak Kanok-Nukulchai

4.9.8 Masters Students' Theses

Applicability of Enhanced Pushover Analysis Methods Considering Higher-Mode Effect for Tall Buildings
By Amelia Kusuma
Supervisor: Dr. Naveed Anwar

Comparison of Different Modeling Techniques for Bridge Abutments, Determination of Abutment Response for Longitudinal Loads and Developments
By Stefani Reni
Supervisor: Dr. Naveed Anwar

Determination of Optimal Microwave Curing Process to Obtain the Highest Early Strength of Normal Concrete
By Adnan Nawaz
Supervisor: Dr. Pennung Warnitchai

Development of a General Purpose Software Package for Offshore Platform Structural Analysis
By Mr. Thanh Huu Le
Supervisor: Prof. Worsak Kanok-Nukulchai

Development of Chemically-Prestressed Ferrocement
By Akira Kodaka
Supervisors: Dr. Pennung Warnitchai / Dr. Raktipong Sahamitmongkol

Development of Microwave Curing Technique to Predict the 28-Day Compressive Strength of Fly Ash Concrete
By Abdul Habib Ghafoorzai
Supervisor: Dr. Thanakorn Pheeraphan

Development of Post-Tensioned Precast Concrete Building Systems for Seismic Resistance
By May Phyo Aung
Supervisor: Dr. Pennung Warnitchai

Diaphragm Effects on Tall Buildings Curved in Plan
By Ja San Lu
Supervisor: Dr. Naveed Anwar

Effective Modeling of Shear Walls in High Rise Buildings for Nonlinear Static and Dynamic Analysis
By Rojit Shahi
Supervisor: Dr. Naveed Anwar

Effects of Typical Configuration Irregularities on Seismic Performance of Gravity-Load-Designed RC Buildings
By Sarun Chimamphant
Supervisor: Dr. Pennung Warnitchai

Enhanced Conductivity Measurement Techniques for Evaluation of Metakaolin Pozzolanic Activity
By Purna Bahadur Chhetri
Supervisor: Dr. Pennung Warnitchai

Estimation of Potential Losses of a Major City from Earthquake Disasters
By Miti Nuntatikul
Supervisor: Dr. Pennung Warnitchai

Flexural Strengthening of Reinforced Concrete Beam Using High Performance Ferrocement
By Kamaluddin Kamal
Supervisor: Dr. Pennung Warnitchai

Impact of Different Design Parameters on the Seismic Performance of Hybrid Precast Wall Systems
By Muhammad Irshad Qureshi
Supervisor: Dr. Pennung Warnitchai

Implementation of New Constitutive Relations for Shear-Flexure Interaction for Cyclic Response of Squat RC Walls
By Omar Hayat
Supervisor: Dr. Pennung Warnitchai

Performance of Metakaolin Mortar Against Carbonation
By Chatree Kittisapcharoen
Supervisor: Dr. Sun Sayamipuk

Properties of High Performance Grouts Made with Various Supplementary Cementitious Materials
By Atipong Chuamuangphan
Supervisor: Dr. Pennung Warnitchai

Properties of Magnesia-Phosphate Cement for Rapid Repair Mortar
By Monsan Visessaghamin
Supervisor: Dr. Sun Sayamipuk

Seismic Performance Improvement of Gravity-Load-Designed (GLD) Reinforced Concrete Frame Buildings

By Phichaya Suwansaya
Supervisor: Dr. Pennung Warnitchai

Seismic Performance of Precast Hybrid Frame-Wall Buildings

By Bahram Babayanzadeh Ahari
Supervisor: Dr. Pennung Warnitchai

Seismic Safety Evaluation of Earth Dam in Northern Thailand

By Bhuddarak Charatpangoon
Supervisors: Dr. Pennung Warnitchai / Dr. Kyung-Ho Park

Self-Healing Performance of Concrete with Different Additives

By Dechkhachorn Jaroenratanapirom
Supervisor: Dr. Pennung Warnitchai

Shear Strengthening of RC Member by Near-Surface Mounted AFRP Rods

By Pongsak Wiwatrojanagul
Supervisor: Dr. Raktipong Sahamitmongkol

Ultimate Drift at Gravity Load Collapse of Non-Ductile RCc Column

By Tahir Mehmood
Supervisor: Dr. Pennung Warnitchai

Utilization of MK-Based Geopolymer as Adhesives for Refractory Brick

By Atinuch Sinsilaket
Supervisor: Dr. Pennung Warnitchai

4.10: SET – TELECOMMUNICATIONS FIELD OF STUDY

4.10.1 Introduction

The **Telecommunications Field of Study** offers areas of specialization in transmission systems; switching systems; telematics; network planning, and in collaboration with the School of Management telecommunications management. The courses offered emphasize modern telecommunications skills in systems planning and engineering, telecommunications software development, and administrative and financial aspects of telecommunications management.

Graduates from the master's program form the nucleus for effective high-level technical planning and management operations at their employer organizations. Some of the graduates are engaged in planning, development, and service activities leading to the installation, commissioning, management, design, etc. of value-added systems. Given the important role of our graduates in the development of the telecommunications sector, the learning is of significant benefit to the users of telecommunications services within the region. Graduates of the doctoral program play key roles in enhancing the level of education and research in the national universities of the region, and promote and strengthen the R&D potential of emerging regional manufacturing industries.

4.10.2 Research Facilities and Laboratories

Today's fast-booming world of Telecommunications and Computer networking plays a significant leadership role. To support this achievement the Telecommunications field of study puts the effort to continue the development of telecommunications technologies and systems. It covers a wide variety of research in telecommunications ranging

from modeling, analysis wire line and wireless systems to application and protocol development. Its research subjects are in coherent optical communications; congestion control, ATM, and B-ISDN networks; error correction and detection methods; mobile and Internet traffic studies; multiple access strategies for cellular mobile, satellite systems, and cabled networks; network performance analysis, planning and design; and speech processing. Its research specializations are in broadband networks; network planning; Switching systems; telecommunications management in collaboration with the School of Management; telematics; and transmission systems.

Transmission and Switching Lab (TSL)

The Transmission and Switching lab is equipped with Nokia Digital Switching Exchange DX200 (DX220, DX210) that supports PSTN and ISDN. There are also several telephone switches, traffic simulators, protocol analyzer, PDH/SDH (STM1 & STM4) transmission systems, fiber optic line equipment, transmission line analyzer, error rate meter which are available for experiment in switching, transmission and internetworking. The switching and transmission systems are integrated as real telecommunications network. Among the applications whose study has been made possible by these systems are Operation and Maintenance, performance measurements of real narrowband and broadband telecommunication networks, as well as new services.

Network Planning Lab (NPL)

High performance computer aided network planning tools are supported by several workstations at the Network Planning lab. This lab provides hands-on experience design

and optimization in radio network, fixed network and fiber optical network.

Wireless Lab (WL)

The main purpose of the Wireless laboratory is for measurement and performance analysis. It is equipped with Modulation and Error rate measurement meters, Simulation software like SATSIM, which was developed by the students, is a simulation package to calculate the sub-satellite points of a LEO/ MEO/GEO and its orbital parameters. It also displays graphically on a two-dimensional earth map the instantaneous position and path traced by the satellite (Multi orbit and Multi satellite). Another is NMS/X, is a measurement system for GSM, DCS and NMT networks tracing, capable of measuring up to four networks simultaneously. The results are used for benchmarking service quality of operational cellular networks. These results can be analyzed and can be used for tuning the network parameters in NPS/X.

Communications Labs (CL)

The Communications lab is used to perform experiments courses under Signal and Systems, Communications Electronics, Digital Transmission Technology and Digital Signal Processing. Test bench equipment includes analog and digital oscilloscopes, function generators, analog and digital Spectrum analyzers, Digital sampling oscilloscopes and DSP cards and workstations which have simulation applications like MATLAB.

Computer Laboratory (PCL)

There are two Computer Laboratories in Telecommunications Program. One is for Senior students

and one is for Junior Students. All computers are latest powerful computers.

TC Library

In Telecommunications Program, there is a small library, from where students can borrow telecommunication related journals, manuals and reference books.

4.10.3 Faculty and Research Staff

Full-time Faculty

KAZI MOHIUDDIN AHMED, MSc, Inst of Communications, Leningrad, USSR; PhD, Univ of Newcastle, Australia.

Professor (*Telecommunication Networks; Digital Modulation Techniques; Satellite Communications; Cellular Mobile Communications; Digital Transmission and Communications*)

R M A P RAJATHEVA, B.Sc. Hons. (Eng), Moratuwa Univ, Sri Lanka; M.Sc., Ph.D. (Electrical and Computer Eng), Univ of Manitoba, Canada.

Associate Professor (*Digital and Mobile Communications, Cooperative Diversity, Relay Systems, OFDMA Resource Allocation, Cognitive Radio: Detection/Estimation Techniques, Space Time Processing-MIMO Systems, Distributed Video Coding (DVC)*)

TEERAPAT SANGUANKOTCHAKORN, BEng, Chulalongkorn Univ, Thailand; MEng, DEng, Tokyo Institute of Technology, Japan.

Associate Professor (*Data Communications; Broadband Integrated Services Digital Networks; Multimedia Communications and Systems; Network Quality of Service*)

POOMPAT SAENGUDOMLERT, BSE, Princeton Univ; MS, PhD, Massachusetts Inst of Tech, USA

Assistant Professor
[*Communication theory, optical networks, resource allocation problems, and array processing; Recent research activities have focused on optical network designs based on existing infrastructure networks and communications for disaster management*]

Visiting Faculty

TAPIO J ERKE, MSc, Helsinki Univ of Tech, Finland.

Visiting Associate Professor
[*Traffic measurements, modeling, and performance in various telecommunication networks, PSTN, Cellular, Internet, ATM, and optical networks; Resource allocation for different services, network dimensioning and optimization, and switching structures*]

4.10.4 Grants and Sponsored Research Completed in 2010

Cross Layer Design for Video Transmission in Multi Hop wireless Networks

Duration: 01 Jan 09 -30 Jun 10
Project Investigator(s): Poompat S.
Sponsor: RTG
Total Contracted Amount (THB): 991,200

4.10.5 On-going Grants and Sponsored Research

Creating Smart Environments through Indoor Optical Wireless Data Transmissions using White light LED's

Duration: 01 Sep 09 - 31 Mar 11
Project Investigator(s): Poompat S.
Sponsor: RTG
Total Contracted Amount (THB): 920,000

4.10.6 Publications

International Journal Articles with Impact factor

E. A. Ansari and N. Rajatheva. (2010). Precise SER Analysis and Performance Results of OSTBC MIMO-OFDM Systems over Uncorrelated Nakagami-m Fading Channels. E93-B (6), pp. 1515-1525, IEICE Transactions on Communications.

Farah Haroon and Kazi M. Ahmed, "An Adaptive IEEE 802.15.4a TH-TDMA UWB Industrial Field Level Network," Special issue on Advances in Wireless Communication, Journal of Communications, Academy Publisher, Vol. 5, No. 7, July 2010.

I. Khan, S. A. K. Tanoli, and N. Rajatheva. (2010). Performance Bounds for Bit-Interleaved Space-Time Coded Modulation with Iterative Decoding based Cooperative Network, Vol 5, No 4 (2010), 297-306, Apr 2010, Journal of Communications.

M. Shamim Kaiser and K. M. Ahmed, Neuro-Fuzzy (NF) based Joint Relay Selection and Resource Allocation for Cooperative Networks. ECTI Transactions on Electrical Eng, Electronics, and Communications (ECTI-EEC), Thailand, 2010

M. Shamim Kaiser and K. M. Ahmed, Neuro-Fuzzy Based Opportunistic Spectrum Access and Hand-off for the Cognitive Cooperative Network. Inderscience Journal of Communication and Distributed Networking (IJCDN). Canada, 2010, [Status: Accept].

M. Shamim Kaiser and K. M. Ahmed, Radio Resource Allocation for Heterogeneous Services in Relay Enhanced OFDMA Systems. Journal of Communications, Academy

Publications, Finland, Vol 5, No 6 (2010), 447-454, Jun 2010

P. Ritthisoonthorn, Kazi M. Ahmed and D. Krairit, " Engineering Analysis and Economic Evaluation of Broadband Fixed Wireless Access in Developing Country: Wireless City in Thailand", The International Journal of Services, Economics and Management (IJSEM), Special Issue on "Design, Integration, and Maintenance of Services for Developing Nations and Economies", 2010.

Ritthisoonthorn P., Kazi Mohiuddin Ahmed, Donyaprueth Krairit. Planning of efficient wireless access with IEEE 802.16 for connecting home network to the internet. Eurasip Journal on Wireless Communications and Networking, (2010) 0-0, 2010.

S. A. K. Tanoli, I. Khan, and N. Rajatheva. (2010). Cooperative Network in wireless communications: bit-interleaved coded modulation with iterative decoding. Vol 5, No 7 (2010), 562-570, Jul 2010, Journal of Communications.

S. Atapattu, N. Rajatheva, C. Tellambura. (2010). Performance analysis of TDMA relay protocols over Nakagami-m fading. IEEE Transactions on Vehicular Technology 59 (1), art. no. 5204231, pp. 93-104.

S. Bharati and P. Saengudomlert (2010), Analysis of mean packet delay for dynamic bandwidth allocation algorithms in EPONs, IEEE/OSA Journal of Lightwave Technology, vol. 28, no. 23, pp. 3454-3462, December 2010.

S. Supittayapornpong, P. Saengudomlert, and W. Kumwilaisak (2010), A framework for reliability aware layered multi-cast in lossy networks with network coding, Computer Communications, vol. 33,

no. 14, pp. 1651-1663, September 2010.

S. U. Oruthota and N. Rajatheva. (2010). Cooperative Diversity based Multi-Carrier CDMA system with Decode & Forward Relays in Rayleigh Fading Channels. In production, Wireless Personal Communications, Springer Journal, September 2010, pp 1-21.

Shujaat Ali Khan Tanoli, Imran Khan, Nandana Rajatheva, and Fumiyuki Adachi (2010) Advances in Relay Networks: Performance and Capacity Analysis of Space-Time Analog Network Coding, EURASIP Journal on Wireless Communications and Networking, Volume 2010 (2010), Article ID 232754, 10 pages doi:10.1155/2010/232754

Teerapat Sanguankotchakorn and Ruenun Urwijitaroon: *QoS Provisioning Strategy for QoS-Unaware Applications in an IntServ/DiffServ Interoperating Network*, International Journal of Computer Science and Network security (IJCSNS), Vol.10, No.5, pp. 261-273, May 2010.

Conference Publications

A. Iqbal and K. M. Ahmed, "SER Analysis of Cooperative Satellite-Terrestrial Network over Non-Identical Fading Channels", 5th Advance satellite Multimedia Systems Conference and 11th Signal Processing for Space Communication Workshop (ASMS/SPSC), Cagliari, Italy, 13-15 September 2010.

A. K. Tanoli, I. Khan, N. Rajatheva (2010). Asymptotic BER bounds of BICM-ID based cooperative network over Nakagami-m fading channels. 25th Biennial Symposium on Communications, QBSC 2010, Canada, art. no. 5472973, pp. 448-451.

Adisorn Lertsinsrubtavee, Teerapat Sanguankotchakorn, Anis Laouiti, and Kanchana Kanchansut: *Velocity*

Effect to the Performance of MANEMO, Asia Future Internet 2010, Seoul National University, Korea, February, 24-27, 2010.

Amina Akhter and Teerapat Sanguankotchakorn: *Modified AODV for Multi-Constrained QoS Routing and Performance Optimization*, The 7th IEEE ECTI-CON 2010, Chiang Mai Thailand, pp.263-267, May 19-21, 2010.

Arif Iqbal, Kazi M. Ahmed and I. Khan, "Outage Probability Analysis for Amplify and Forward Cooperative Protocol in Satellite Network", Proceedings 24th WWRF, Malaysia, 12-14 April 2010.

E. A. Ansari and N. Rajatheva. (2010). Low-pass filtering through different types of windows in linear time. 10th International Conference on Information Sciences, Signal Processing and their Applications, ISSPA 2010 , art. no. 5605479, pp. 243-246

Farah Haroon and Kazi M. Ahmed, "An Adaption of IEEE 802.15.4a in an IR-TH UWB Industrial Field Bus", IEEE 8th International Conference on Industrial Informatics, INDIN 2010, PP 531-536, July 2010.

Farah Haroon, Haroon Rasheed and Kazi M. Ahmed, "A Robust Reception of IEEE 802.15.4a IR-TH UWB in Dense Multipath and Gaussian Noise," International Conference on Computer Science and Information Technology, ICCSIT, PP. 298-303, Rome, Italy, April 2010.

Farah Haroon, Haroon Rasheed and Kazi M. Ahmed, "An Adaptive Srake Reception of Biorthogonal IR-TH UWB signals in IEEE 802.154a Industrial NLOS Environment," IEEE International Conference on Wireless Communications, Networking and Information Security, WCNIS June 2010, Beijing, China.

Farah Haroon, Kazi M. Ahmed and Haroon Rasheed, "An Adaption of IEEE 802.15.4a in an IR-TH UWB Industrial Field Bus," accepted for oral presentation in 8th IEEE International Conference on Industrial Informatics, INDIN July 2010, Osaka, Japan.

H. Rasheed, F. Haroon, N. Rajatheva, (2010). Performance analysis of rice-lognormal channel model for spectrum sensing. ECTI-CON 2010 - The 2010 ECTI International Conference on Electrical Engineering/Electronics, Computer, Telecommunications and Information Technology, art. no. 5491455, pp. 420-424.

H. Rasheed, N. Rajatheva, F. Haroon (2010). Spectrum Sensing with energy detection under shadow fading condition. ISWPC 2010 – IEEE 5th International Symposium on Wireless Pervasive Computing art no. 5483721, pp 104-109.

Haroon F., Kazi Mohiuddin Ahmed, Rasheed H.. An adaption of IEEE 802.15.4a in an industrial Field Bus. IEEE International Conference on Industrial Informatics (INDIN), () 0-0, 2010.

Jagadish Ghimire, Mehdi Mani, Teerapat Sanguankotchakorn and Noel Crespi: *Self-connectivity Estimation for Super Node Overlay Creation in Ad-hoc Networks*, The IEEE 17th International Conference on Telecommunications (ICT2010), Doha, Qatar, April 4-7, 2010.

Jagadish Ghimire, Mehdi Mani, Teerapat Sanguankotchakorn and Noel Crespi: *Delay and capacity Analysis of Structured P2P Overlay for IP Telephony*, 2010 International Symposium on Performance Evaluation of Computer and Telecommunication Systems (SPECTS10), Ottawa, Canada, July 11-14, 2010.

K.B.Shashika Manosha, Nandana Rajatheva. (2010) Joint Power and Rate Control for Spectrum Underlay in Cognitive Radio Networks with a Novel Pricing Scheme, IEEE VTC 2010 Fall, Ottawa, Canada.

K.G.A Madushan Thilina, Nandana Rajatheva. (2010) Impact of Imperfect Channel Estimation on MIMO Two Hop Relay Network with Beamforming. IEEE Globecom 2010, December, Miami, USA

Kunagorn Kunavut and Teerapat Sanguankotchakorn: *Multi-constrained Path (MCP) QoS Routing in OLSR based on Multiple Additive QoS Metrics*, The 10th IEEE International Symposium on Communications and Information Technologies Technology (ISCIT2010), Meiji University, Tokyo, Japan, October 26-29, 2010.

Kunagorn Kunavut and Teerapat Sanguankotchakorn: *Performance Evaluation of Ad Hoc Routing Protocol to deliver MPEG-4 Traffic*, The 12th IEEE International Conference on Communication Technology (ICCT2010), Najing, China, November 11-14, 2010.

Kunagorn Kunavut and Teerapat Sanguankotchakorn: *QoS-aware Routing for Mobile Ad Hoc Networks based on Multiple Metrics: Connectivity Index (CI) and Delay*, The 7th IEEE ECTI-CON 2010, Chiang Mai Thailand, pp.46-50, May 19-21, 2010.

L.K. Saliya Jayasinghe, Nandana Rajatheva. (2010) Optimal Power Allocation for Relay Assisted Cognitive Radio Networks, IEEE VTC 2010 Fall, Ottawa, Canada.

M. Nazir, N. Rajatheva (2010). Cooperative cognitive wireless communication based on biological mutualism. Second International Conference on Networks and Applications (ICCSNA), Page(s): 115 – 118.

M. Nazir, N. Rajatheva (2010). Relay Selection Techniques in Cooperative Communication Using Game Theory. Second International Conference on Computational Intelligence, Communication Systems and Networks (CICSyN), Page(s): 130 – 136.

M. Shamim Kaiser and K. M. Ahmed, Neuro-Fuzzy (NF) based Relay Selection and Resource Allocation for Cooperative Networks. IEEE ECTI-CON 2010, Chiang Mai, Thailand, 2010.

M. Shamim Kaiser and K. M. Ahmed, Power Allocation in OFDM-Based Cognitive Relay Networks. IEEE International Conference on Wireless Communications, Networking and Information Security (IEEE WCNIS 2010), China, 2010.

M. Shamim Kaiser, Arif Iqbal, Samad Basir and K. M. Ahmed, Performance Evaluation of a Network coded Dual-hop OFDM Network. IEICE 2010, BUET, Dhaka, Bangladesh.

Ranju Pant and Teerapat Sanguankotchakorn: *A Heuristic Approach for Bandwidth Constraint Path Selection in MPLS Based Networks*, The 7th IEEE ECTI-CON 2010, Chiang Mai Thailand, pp.909-913, May 19-21, 2010.

S. Herath, N. Rajatheva and P. Saengudomlert. (2010). Primary and Cognitive User Cooperative Spectrum Sensing in OFDMA Air Interface. IEEE VTC 2010 Spring, Taipei, Taiwan.

Samad Basir, Ibrahim Channa, M. Shamim Kaiser, and K. M. Ahmed, Reliable and Optimal Relay Selection For The Cellular Cooperative Diversity System Under Rayleigh Fading Channel. WPMC 2010, Brazil, 2010.

Shujaat Ali Khan Tanoli, Imran Khan and Nandana Rajatheva. (2010) Performance Comparison of BICM-ID and BILDPCM-ID based Cooperative

Network, IEEE VTC 2010 Fall, Ottawa, Canada.

Srikantha Herath, R.M.A.P.
Rajatheva, Poompat Saengudomlert.
Primary and cognitive user cooperative spectrum sensing in OFDMA air interface. IEEE Vehicular Technology Conference, () 0-0, 2010.

Supittayapornpong S., Poompat Saengudomlert. Joint flow control, routing and medium access control in random access multi-hop wireless networks. IEEE International Conference on Communications, () 0-0, 2010.

Teerapat Sanguankotchakorn and Newton Perera: *Hybrid Multi-constrained Optimal Path QoS Routing with Inaccurate Link State*, The 9th International Conference on Networks (ICN2010), Menuires, The Three Valleys, French Alps, France, April 11-16, 2010.

Viphavakit C., Sohail M., Shrestha N., Poompat Saengudomlert, Mohammed W.S.. Creating a smart environment using optical wireless. Proceedings of SPIE - The International Society for Optical Engineering, (7743) 0-0, 2010.

Z.A. Khan, I. Khan, N. Rajatheva (2010). Performance analysis of MIMO based multi-user cooperation diversity system using hybrid FDMA-TDMA technique. ECTI-CON 2010 - The 2010 ECTI International Conference on Electrical Engineering/Electronics, Computer, Telecommunications and Information Technology, art. no. 5491456, pp. 425-429

4.10.7 Doctoral Students' Dissertation

Designing Cost Effective Broadband Fixed Wireless Access Networks through Engineering-Economic Analysis
By Pichet Ritthisoonthorn
Supervisors: Prof. Kazi Mohiuddin Ahmed / Dr. Donyaprueth Krairit

Neuro -Fuzzy Based Relay Selection and Fair Resource Allocation in Cognitive Cooperative Networks

By M. Shamim Kaiser
Supervisor: Prof. Kazi Mohiuddin Ahmed

Performance Analysis of FDMA-TDMA Based Multi-User Cooperative Network over Rician and Nakagami Fading Channels

By Imran Khan
Supervisor: Dr. R.M.A.P. Rajatheva

4.10.8 Masters Students' Theses and Research Studies

Amplifier Placement for Metropolitan WDM Ring Networks Supporting Different Traffic Demands

By Nguyen Van Nhan
Supervisor: Dr. Poompat Saengudomlert

Analysis of Cooperative Relay Communication with Cognitive Radio, Physical Layer Network Coding and MIMO

By Laddu Keeth Saliya Jayasinghe
Supervisor: Dr. R.M.A. Premanandana Rajatheva

A New Approach for QoS Provision Based on Multi-Constrained Feasible Path Selection in Manet OLSR Protocol

By Mr. Padam Maharjan
Supervisor: Dr. Teerapat Sanguankotchakorn

Call Admission Control in Cellular/WLAN Network

By Reena Manandhar
Supervisor: Dr. Tapio J. Erke

Content Discovery Using People Social Pattern in Peer-to-Peer Networks

By Sraddha Adhikari
Supervisor: Dr. Teerapat Sanguankotchakorn

Dimensioning of Optical Networks with Alternate Routing Using Absorption Probability

By Sarbagya Buddhacharya
Supervisor: Dr. Poompat Saengudomlert

Effective and Strict Multi-Constrained Path Selection for QoS Provision in Manet

By Avishek Shrestha
Supervisor: Dr. Teerapat Sanguankotchakorn

Epidemic Dissemination of Event Information on Optimized Link State Routing Protocol (OLSR)

By Mr. Wattanadej Jutacharoensuk
Supervisor: Dr. Teerapat Sanguankotchakorn

Integration of Delay Tolerant Network Approach on Mobile Ad Hoc Network

By Mr. Rujipol Virochpoka
Supervisor: Dr. Teerapat Sanguankotchakorn

Performance Evaluation of Dynamic Bandwidth Allocation Algorithms for WDM-EPONS

By Nakrop Jinaporn
Supervisor: Dr. Teerapat Sanguankotchakorn

Performance Improvement of OLSR in Manet by Game Theory

By Thanapol Sangsrichun
Supervisor: Dr. Teerapat Sanguankotchakorn

Resource Allocation in Cellular Relay Network Using Network Coding

By Nawat Luangviriyasaeng
Supervisor: Dr. Poompat Saengudomlert

Study of the Suitable Coverage Area for Digital Terrestrial Television Broadcasting Service

By Hajime Kikumura
Supervisor: Dr. Teerapat Sanguankotchakorn

The Cross Layer Framework for Efficient MPEG-4 Video Streaming Over IEEE 802.11e EDCA

By Mr. Kumar Pudashine
Supervisor: Dr. Teerapat Sanguankotchakorn

User-Centric Mashup Applications and User-Acceptance Analysis: An Example of iGoogle Based Widgets on the Google Calendar Platform

By Miss Sirsha Bhattarai
Supervisor: Dr. Teerapat Sanguankotchakorn

Research Study: Capacity and Design Planning of Special Event - Mobile Solution: A Case Study in NASCAR Motor Sport

By Fahim Mohammad Khan
Supervisor: Dr. Tapio J. Erke

Research Study: Fixed Network Traffic Observation and Analysis: A Case Study of Tra Vinh Province, Vietnam

By Thach Thi Via Sa Na
Supervisor: Prof. Kazi Mohiuddin Ahmed

Research Study: Investigation of Transmission Coverage for Indoor Optical Wireless Communications Using ASAP

By Syed Muzamil Ali Bokhari
Supervisor: Dr. Poompat Saengudomlert

Research Study: Performance Analysis of Dynamic Bandwidth Allocation Algorithms in Ethernet Passive Optical Networks Under Different Traffic Statistics

By Unchalee Sangkamanee
Supervisor: Dr. Poompat Saengudomlert

Research Study: Performance Analysis of Ku-Band and Ka-Band Satellite Links with Prediction of Rain Attenuation: A Case Study in Makassar, Indonesia

By Muhammad Mimsyad
Supervisor: Prof. Kazi Mohiuddin Ahmed

Research Study: Performance Comparison of AODV Routing Protocol in Homogeneous and Heterogeneous Manets

By Miss May Myint Htwe
Supervisor: Dr. Teerapat Sanguankotchakorn

Research Study: Performance Comparison of OLSR Routing Protocol in Homogeneous and Heterogeneous Manets

By Mr. Thein Tun Aung
Supervisor: Dr. Teerapat Sanguankotchakorn

Research Study: Performance Study of Dynamic Bandwidth Allocation Based on GEPON Systems at CAT Telecom in Thailand

By Surachai Amorncheewasinlapakul
Supervisor: Dr. Poompat Saengudomlert

Cross-Layer Design for Video Transmission in Multi-Hop Wireless Networks



In this research project, we apply optimization and network coding techniques to the problem of efficient video transmission over wireless multi-hop networks. In particular, we construct a framework for reliability aware layered multi-cast of multimedia information. The framework can provide a theoretical benchmark for the amount of information rates that can be supported with QoS guarantees in terms of the probabilities of successful packet transmissions. We also develop a computer program to simulate the effects of packet losses on the video transmission quality. The developed program can display the reconstructed video images with various levels of packet losses (as shown in the figure) as well as compute the associated peak signal-to-noise ratios.

4.11: SET – TRANSPORTATION ENGINEERING FIELD OF STUDY

4.11.1 Introduction

Industrialization and population growth have tremendous impacts in the movement of people and goods. Everyday, movement is hampered by congestion, insufficiency of public transport facilities, traffic accidents, and other conditions. Moreover, as manufacturing expands globally, businesses want to reduce transportation costs by limiting the number of distribution nodes. Concerns over congestion on highways, increasing pollution and hazardous materials all emphasize the need to effectively maximize transportation systems. Thus, the issue of transportation is obviously crucial, not only now but in the future.

The **Transportation Engineering** field exposes students to the process of alleviating transportation problems. The coursework and research in the area provide advanced knowledge in transportation planning and economics, traffic engineering and safety, and the design of highways/pavements and other transportation facilities. Transportation Engineering students acquire advanced skills concerning the planning, design, operations, maintenance, rehabilitation, performance, and evaluation of transportation systems, including their economic and public policy aspects. The field imbues in each student the development of analytic, problem-solving, design, and management skills suitable for public and private sector professional work.

4.11.2 Faculty and Research Staff

Emeritus Professor

JOHN HUGH JONES, B.S., B.Eng.,
University of California, USA
(*Highway Engineering,
Transportation Engineering*)

Full-time Faculty

HYUNMYUNG KIM, PhD, University of California, Irvine, USA; MSc, BEng, Seoul National University, Korea.

Assistant Professor

[Transportation demand modeling, transportation network analysis, dynamic traffic simulation, activity-based travel analysis, dynamic OD estimation problem, public transportation planning, sustainable transportation planning problem]

KUNNAWEE KANITPONG, Ph.D., University of Wisconsin- Madison; M.Sc., University of Maryland at College Park, USA; B.S., Chulalongkorn University, Thailand.

Assistant Professor [*Highway pavements with emphasis on several major aspects including: highway materials and construction, pavement design and analysis, pavement management system, asphalt rheology, and asphalt concrete mixture design*]

THIRAYOOT LIMANOND, Ph.D., University of California, Davis, USA; M.S., Arizona State University, USA; B. Eng., Chulalongkorn University, Thailand

Assistant Professor (*Sustainable transport, travel demand, transportation planning, traffic engineering, transport energy planning, intelligent transportation system*)

Visiting Faculty

HIRONORI KATO, D.Eng., M.Eng., B.Eng., University of Tokyo, Japan
Visiting Associate Professor (*Transportation planning and policy; travel behavioral analysis; transportation project evaluation*)

KAZUSHI SANO, D.Eng., M.Eng., B.Eng., University of Tokyo, Japan

Visiting Associate Professor (*Transportation Planning, Traffic Engineering, and Logistics*)

SHINYA HANAOKA, Dr.Info.Sc., M.Info .Sc., B.Eng., Tohoku University, Japan.

Visiting Associate Professor [*Transport planning and logistics; air transport, which includes evaluation of the air traffic distribution policies in multiple-airport region and the activity of low-cost carriers in Asia; transport logistics, which includes city logistics, intermodal logistics, maritime transport, air cargo and so on; Public transport market and the environmental impact of transport, such as air pollution and noise*]

TAKASHI NAKATSUJI, D. Eng., M. Eng., B. Eng., Hokkaido University, Japan.

Visiting Professor (*Traffic Engineering, Traffic Flow Simulation, Winter Maintenance, Traffic Accident Reconstruction*)

Adjunct Faculty

PIYAPONG JIWATTANAKULPAISARN, Ph.D., Imperial College London, United Kingdom; M.Eng., Asian Institute of Technology, Thailand; B. Eng., Chulalongkorn University, Thailand.

(*Wider Economic Impacts of Transport Infrastructure, Highway Development and Land Use, Financing Transport Infrastructure, Econometric Modeling for Policy Analysis, Statistical and Quantitative Methods for Transportation Analysis, Fuel Demand Modeling, Accident Risk Behaviours of Road Users,*

Traffic Safety Engineering and Evaluation of Road Safety Interventions

Research Staff

PREDA JATURABONG, M.Eng. (Transportation Engineering), Asian Institute of Technology; B.Eng. (Civil Engineering), Kasetsart University, Bangkok, Thailand.

Research Associate

SATTRAWUT PONBOON, M. Eng. (Transportation Engineering), Asian Institute of Technology, Thailand; B.Eng. (Transportation Engineering), Suranaree University of Tech., Nakhon Ratchasima, Thailand.

Research Associate

SUMETHEE SONTIKUL, M. Eng. (Transportation Engineering), Asian Institute of Technology; B. Eng. (Civil Engineering), King Mongkut’s Institute of Technology Ladkrabang, Bangkok, Thailand.

Research Associate

SUPATTRA SAMRANJIT, M.A. (Library and Information Science), Ramkhamhaeng University; B.A. (Communication Arts) Bangkok University, Bangkok, Thailand.

Research Associate

4.11.3 Grants and Sponsored Research Completed in 2010

Dual Degree Master Program in Transportation Engineering in Indonesia Batch II

Duration: 01 Feb 09 -31 Dec 10
Project Investigator(s): Kunnawee Kanitpong
Sponsor: Multi donors
Total Contracted Amount (THB): 1,880,000

Promoting Cool Pavements to Mitigate the Urban Heat Island effect in Bangkok

Duration: 15 Oct 08 -30 Sep 10
Project Investigator(s): Kunnawee Kanitpong
Sponsor: RTG
Total Contracted Amount (THB): 980,000

Road Safety Engineering Training in Bangkok for HDC Dong Nai team

Duration: 13 Nov 09 -30 May 10
Project Investigator(s): Kunnawee Kanitpong
Sponsor: Handicap International Vietnam
Total Contracted Amount (THB): 280,335

4.11.4 On-going Grants and Sponsored Research

Accident in Depth Study Training and workshop

Duration: 22 Jun 10 - 30 Apr 11
Project Investigator(s): Kunnawee Kanitpong
Sponsor: Siam Cement Group (SCG)
Total Contracted Amount (THB): 96,300

An Agent based Dynamic simulation Model for Tour Area evaluation

Duration: 01 Jul 09 - 30 May 11
Project Investigator(s): Hyunmyung Kim
Sponsor: RTG
Total Contracted Amount (THB): 1,000,000

Analysis of Accident Cost in Thailand by Willingness to Pay Method

Duration: 13 Jan 10 - 30 Apr 11
Project Investigator(s): Kunnawee Kanitpong
Sponsor: Mitsui Sumitomo Insurance Welfare Foundation
Total Contracted Amount (THB): 150,000

Improving Road Traffic safety in Thailand:A common challenge for european and Thai Universities

Duration: 24 Dec 08 - 30 Apr 11
Project Investigator(s): Kunnawee Kanitpong
Sponsor: Commission of the European Communities
Total Contracted Amount (THB): 8,317,938

Knowledge Dissemination to Improve Road Safety for Rural Community

Duration: 01 Sep 08 - 30 Jun 11
Project Investigator(s): Kunnawee Kanitpong
Sponsor: Toyota Motor Thailand Co., Ltd.
Total Contracted Amount (THB): 1,605,000

Road Safety Knowledge Development and Dissemination

Duration: 01 Jun 08 - 30 Jun 11
Project Investigator(s): Kunnawee Kanitpong
Sponsor: Department of Highways, Thailand
Total Contracted Amount (THB): 7,756,000

Road Safety Watch Central Region

Duration: 01 Apr 10 - 30 Jun 11
Project Investigator(s): Kunnawee Kanitpong
Sponsor: Thai Roads Foundation
Total Contracted Amount (THB): 1,826,600

4.11.5 Publications

International Journal Articles with Impact factor

Boontaveeyuwat P., Shinya Hanaoka. Analysing the optimal location of a hub port in Southeast Asia. International Journal of Logistics Systems and Management, 4(6) 0-0, 2010.

Choi K., Jayakrishnan R., Hyunmyung Kim, Yang Yi, Lee J.. Dynamic origin-destination estimation using dynamic traffic simulation model in an urban arterial corridor. Transportation Research Record, 2133() 0-0, 2010.

Kanitpong, K., Charoentham, N., and Likitlersuang, S., “Investigation of Moisture Damage in Warm-Mix Asphalt Using Dynamic Creep Test,” Submitted to the International Journal of Pavement Engineering, 2010. (Accepted for publication) (SCI Journal)

Kanitpong, K. and Pummarin, K., “Investigation of Using Industrial Wastes in Moisture Damage Resistance of Hot Mix Asphalt Pavement,” Journal of Solid Waste Technology and Management, Vol.36, No.2, May 2010, pp.81-90. (SCOPUS citation:0)

Phuntsho, S. and Kanitpong, K., “Vehicle Emission Control Strategies and Public Opinion in Bhutan,” Transportation Research Record, Journal of the Transportation Research Board, 2010. (in press) (SCI Journal)

Shinya Hanaoka, Phoosanabhongs E.. Estimation of the occurrence of short-shipping of air cargo. Journal of Air Transport Management, 6(16) 0-0, 2010.

Shinya Hanaoka, Qadir F.M..
Passengers' perceptions and effects
of bus-holding strategy using
automatic vehicle location
technology. *Journal of Advanced
Transportation*, 3(43) 0-0, 2010.

4.11.6 Doctoral Students' Dissertation

*Experimental Investigation of Skid
Resistance and Surface Texture on
Asphalt Pavements in Thailand*

By Chanida Kangkhajitre
Supervisor: Dr. Kunnawee Kanitpong

*Measurement of Visibility Loss Index Due
to Splash and Spray on Thailand
Highways*

By Pichaya Rungruangvirojn
Supervisor: Dr. Kunnawee Kanitpong

4.11.7 Masters Students' Theses and Research Studies

*A Dynamic Traffic Simulation for
Emergency Situations in Urban Road
Network*

By Jakarin Phiriyajitta
Supervisor: Dr. Hyunmyung Kim

*Analysis of Accident Costs Using the
Willingness-To-Pay Method Among
Motorcycle Users in Bangkok and
Surrounding Areas*

By Preeda Chaturabong
Supervisor: Dr. Kunnawee Kanitpong

*A Study of Awareness in Urban
Transportation Sustainability*

By Hnin Yu Aung
Supervisors: Dr. Kunnawee Kanitpong / Dr.
Hyunmyung Kim

*Calibration of Traffic Noise Prediction
Model in Thailand*

By Wang-a-pisit Ornkamon
Supervisor: Dr. Kunnawee Kanitpong

*Correlation Analysis Between
International Roughness Index and
Pavement Distresses: A Case Study of*

*Central Java Province National Highways,
Indonesia*

By Natalia Rahmawati Aruan
Supervisors: Dr. Kunnawee Kanitpong/Ir. Djoko
Murwono (UGM)

*Evaluation of Walking Path Along Silom
Road*

By Siwatat Sri-on
Supervisors: Dr. Kunnawee Kanitpong / Dr.
Hyunmyung Kim

*Evaluating the Accessibility of Bangkok
Public Transport Networks*

By Than Htike Oo
Supervisors: Dr. Kunnawee Kanitpong / Dr.
Hyunmyung Kim

*The Development of Land-Use and
Transportation Integrated Model for
Urban Sustainability Evaluation*

By Ajay Khatri Chettri
Supervisors: Dr. Kunnawee Kanitpong / Dr.
Hyunmyung Kim

*Research Study: Albedo and Temperature
Measurements of Selected Pavement
Surfaces*

By Muhammad Ihsan
Supervisor: Dr. Kunnawee Kanitpong

*Research Study: Cold Mix Recycling with
Foamed Bitumen Mix Design for Binder
Course (Laboratory Study)*

By Yuanita Kiki Sani
Supervisors: Dr. Kunnawee Kanitpong/Dr. Latif Budi
Supama (UGM)

*Research Study: Cross Section Condition
in Urban Areas: The Case of Arterial and
Collector Roads in Yogyakarta, Indonesia*

By I Putu Gede Sudarma
Supervisor: Dr. Kunnawee Kanitpong

*Research Study: Effect of Aging on AC-WC
Hot Mix Asphalt Utilizing Bituminous
Waste Material*

By Indra Rismawansyah
Supervisor: Dr. Kunnawee Kanitpong

*Research Study: Implementation of
Indonesian Integrated Road
Management for Pavement Maintenance
(Case Study of Pantura Road)*

By Devi Utari Hidayah Siregar
Supervisors: Dr. Kunnawee Kanitpong/Ir. Djoko
Murwono (UGM)

*Research Study: Laboratory Investigation
of Skid Resistance for Steel Slag
Utilization as Chip Seal*

By Laely Fitria Hidayatiningrum
Supervisor: Dr. Kunnawee Kanitpong

*Research Study: Laboratory Performance
of Asphalt Pavement Surface Using Steel
Slag and Natural Aggregate*

By Kokoh Maha Sembada
Supervisors: Dr. Kunnawee Kanitpong/Dr. Latif Budi
Supama (UGM)

*Research Study: Road Cross Section
Regulation Study*

By I Putu Gede Sudarma
Supervisor: Dr. Kunnawee Kanitpong

*Research Study: Sensitivity Analysis in
Flexible Pavement Performance Using
Mechanistic Empirical Model (Case Study:
Cirebon-Losari Road Segment, West Java)*

By Edovita Samad
Supervisors: Dr. Kunnawee Kanitpong/Dr. Wardhani
Sartono (UGM)

*Research Study: Sensitivity Analysis on
Concrete Pavement Performance Using
Finite Element Approach*

By Yonatan Hendrik Parjoko
Supervisor: Dr. Kunnawee Kanitpong



Road safety watch project: involves developing a road users risk behaviours assesment system and monitor a road safety situation in Thailand

4.12: SET – WATER ENGINEERING AND MANAGEMENT FIELD OF STUDY

4.12.1 Introduction

Today's major challenges for water engineers and managers include securing water for people and for food production, protecting vital ecosystems, and dealing with climate variability and change and uncertainty of water in space and time. The Water Engineering and Management (WEM) imparts education and training towards an understanding of the complexity of water cycle, utilization, and management. It offers a balanced curriculum covering both engineering and management aspects of water resources. Students acquire knowledge and hands-on practice in tools and techniques to come up with viable and sustainable water management for water, food, energy, and environmental security. Students conduct research on country-specific water related problems, and have opportunities to join research and internship programs with industries and partners.

The WEM field of study covers five focal areas: Agricultural Water, Coastal Water, Urban Water, Water Resources, and Extreme Events and Risk Management. The courses are designed in such a way that students can specialize according to their interests. Courses on Watershed Hydrology, Hydrodynamics, Water Resources Systems, and Concepts in Water Modeling provide the solid foundation to the advanced courses. The curriculum emphasizes tools and techniques in water resources planning and management.

Agricultural Water courses impart knowledge and skills necessary for the development and management of water resources for agriculture. They address various multi-disciplinary issues in the planning, design, implementation, operation and maintenance of irrigation and drainage projects and land and water conservation programs. Current researches in the area include irrigation

and drainage system management, cropping systems, erosion and water quality problems, soil conservation and land-use, and watershed management. The management and design of sound engineering works for the control and effective use of coastal zones require in-depth knowledge of hydrodynamics and the understanding of coastal zone phenomena. Coursework and research in Coastal Water cover studies of wave characteristics and their action on beaches, coastal sedimentation, estuarine hydraulics and the applied aspects of coastal zone engineering and management.

Urban Water courses relate to water supply and sanitation, storm water, and domestic wastewater and urban drainage for sustainable management of urban areas. The research in relation to urban water focuses on application of state-of-the-art theory in water demand forecasting and management, design and management of water distribution systems in urban and rural areas, real-time hydrological information systems for urban flooding and drainage. Given the ever-growing importance of water quality, an integrated water quantity-quality approach is essential. Courses in Water Resources focus on techniques to assess the occurrence and availability of surface and groundwater. Students acquire a sound understanding of basic principles in river engineering and modeling, water resources planning, conjunctive use of surface and groundwater; integrated water resources management and social and environmental impact assessment of water resources projects. In-depth knowledge and hands-on practice on mathematical modeling of water resources systems is provided. Flooding is a natural phenomenon and various human activities as well as climatic changes have aggravated the problem causing economic losses. Students are exposed to an understanding of the behavior of rivers, and to design appropriate structural and non-structural

alternatives for the effective management of rivers and waterways. Research in the area of Extreme Events and Risk Management includes river flow analysis, and flood control and mitigation, flood modeling and forecasting, flood plain development and management.

4.12.2 Faculty and Research Staff

Emeritus Professor

ASHIM DAS GUPTA, BEng, Gauhati Univ, India; MEng, DEng, AIT, Thailand.

Visiting Professor (*Integrated Water Resources Management; Groundwater Development and management; Modeling and monitoring*)

Full-time Faculty

MUKAND S BABEL, BEng, Rajasthan Agr Univ, India; MEng, DEng, AIT.

Associate Professor [*Hydrologic and water resources modeling as applied to integrated water resources management; watershed modeling and management; water resources allocation and management; water resources and socio-economic development; water supply system and management; climate change impact and adaptation; groundwater resources management; and drought analysis, forecasting and management*]

ROBERTO CLEMENTE, BSAE, Univ of the Philippines at Los Baños; MEng, AIT, Thailand; PhD, McGill Univ, Canada.

Associate Professor [*Focal areas related to irrigation/drainage, and land and water resource assessment and management;*

Studies on the impacts of fertigation on water quality, modeling surface/subsurface transport of water and solutes, performance evaluation of irrigation and drainage systems, and assessment of soil erosion hazard and soil quality dynamics in agricultural watersheds; Joint research on water harvesting and management and soil hydraulic characterization in sloping agricultural lands; Future research focuses on evaluation and optimization of soil, water, chemical and crop management schemes to enhance agricultural productivity without jeopardizing environmental quality]

SANGAM SHRESTHA, MSc., Institute of Agriculture and Animal Science, Tribhuvan University, Nepal; MSc., Asian Institute of Technology, Thailand; PhD., University of Yamanashi, Japan.

Assistant Professor [*Climate Change and Adaptation, Integrated Water Resources Management, Hydrology and Water Quality Modeling, Groundwater Development and Management, Sustainable Water Management Policy*]

Visiting Faculty

ASHIM DAS GUPTA, BEng, Gauhati Univ, India; MEng, DEng, AIT, Thailand.

Visiting Professor [*Integrated Water Resources Management; Groundwater Development and management; Modeling and monitoring*]

TAWATCHAI TINGSANCHALI, BEng, Chulalongkorn Univ, Thailand; MEng, DEng, AIT, Thailand.

Visiting Professor [*Flood Control Engineering and Management; Flood Forecasting, Warning and Flood Disaster Management; River Engineering and Hydropower; Water Resources Project System Optimization*]

SYLVAIN PERRET, MS and PhD, University of Montpellier II, France; DSc, Ecole Polytechnique de Lorraine, Nancy, France.

Visiting Associate Professor [*Water economics and governance, with special interest onto valuation approaches of rural and environmental water uses, irrigation systems' performances and evaluation, environmental assessment of production systems, governance in irrigation systems, integrated water resource management and governance at the river basin level, social participation in the water sector*]

DAMIEN JOURDAIN, BEng, MSc, Ecole Nationale Supérieure Agronomique Montpellier, France; PhD, University of Montpellier I, France

Visiting Assistant Professor [*Agricultural & Natural Resources Economics / Farm Modeling / Water and Watershed Management / Payment for Environmental Services*]

BANERJEE GOUTAM, BE (Civil) Bangal Engg. College; M.Tech (Env. Engg.) and PhD (Civil Engg) IIT. Kharagpur, India

Visiting Professor [*Water & Wastewater Treatment, Industrial Waste Treatment, Solid & Hazardous Waste Management, Environmental Impact Assessment, Environment Monitoring*]

Affiliated Faculty

SUTAT WEESAKUL, DEng, MEng, Asian Institute of Technology; BEng, Chulalongkorn University, Thailand
[*Numerical computation in sea and coastal area including flood propagation using developed computer programs; Application in solving urban drainage problem using both engineering and management approaches; the on-line urban flood warning*

system at Sukhumvit , Bangkok , Thailand providing useful information in daily life during rainy season are disseminated in <http://www.wap.ait.ac.th>; Improvement of hydraulic design using physical hydraulic model test in hydropower; hydropower development projects in Lao and Myanmar and improvement in design of intake, diversion tunnel, riparian outlet, energy dissipater, spillway and head pond]

4.12.3 Grants and Sponsored Research Completed in 2010

3rd Batch of E-learning Program on Integrated Water Resources Management

Duration: 01 Mar 08 -31 Dec 10
Project Investigator(s): Mukand S. Babel
Sponsor: UNU-INWEH and participants
Total Contracted Amount (THB): 936,000

A Study of Exploration Drilling in Concession Block B6/27 Gulf of Thailand

Duration: 01 Apr 09 -31 May 10
Project Investigator(s): Sutat Weesakul
Sponsor: ERM-Siam Company Limited
Total Contracted Amount (THB): 1,200,000

Asian Infrastructure Research Center (AIRC) Phase I

Duration: 01 Jan 07 -31 Dec 10
Project Investigator(s): Mukand S. Babel, Noppadol Phienweij, Kyung-Ho Park, BHW Hadikusumo, Kunnawee Kanitpong
Sponsor: Konkuk University, South Korea
Total Contracted Amount (THB): 4,472,153

Case Study on Urban Water, Wastewater and Storm Water Management in Bangkok

Duration: 01 Jun 09 -31 May 10
Project Investigator(s): Mukand S Babel
Sponsor: IWP,NUS,Singapore
Total Contracted Amount (THB): 330,000

Development of Operational Flood forecasting System (Phase II)

Duration: 01 Sep 09 -31 Aug 10
Project Investigator(s): Sutat Weesakul
Sponsor: National Electronics and Computer Technology Center, Thailand
Total Contracted Amount (THB): 1,104,600

EWRI -AIT An International Perspective on environmental and Water Resources Conference 2009 (UNESCO)

Duration: 01 Dec 08 -30 Dec 10
Project Investigator(s): Mukand Babel
Sponsor: UNESCO
Total Contracted Amount (THB): 735,200

Investigation of flow dynamics in Mhahchai Sanamchai canal network by physical and Mathematical models

Duration: 01 Nov 08 -31 Oct 10
Project Investigator(s): Sutat Weesakul
Sponsor: RTG
Total Contracted Amount (THB): 930,000

PhD Short Course cum Workshop on "Advances in Agricultural Water Productivity assessment and improvement in irrigation schemes"

Duration: 01 Sep 09 -31 Aug 10
Project Investigator(s): Mukand S Babel
Sponsor: FIVA,DWF,University of Copenhagen
Total Contracted Amount (THB): 1,440,000

Physical Model for Monkey Cheeks in the Mahachai-Sanamchai Canals Project: The King of Thailand's Initiative

Duration: 01 Jul 08 -30 Nov 10
Project Investigator(s): Sutat Weesakul
Sponsor: Hydro and Agro Informatic Institute (HAII)
Total Contracted Amount (THB): 2,164,182

Regional Refresher Seminar on Disaster Management of Urban Water systems under Climate Change

Duration: 01 Oct 09 -31 Dec 10
Project Investigator(s): Mukand Babel
Sponsor: UNESCO-IHE
Total Contracted Amount (THB): 1,372,800

Study on Coastal and Oceanography condition for construction of Nuclear Power Plant: A case Study of Thachana

Duration: 01 Dec 09 -31 Dec 10
Project Investigator(s): Sutat Weesakul
Sponsor: ATT Consultants Company Ltd
Total Contracted Amount (THB): 858,996

UNEP-IIDED Project on Rice Ecosystem Services

Duration: 07 Jun 10 -31 Aug 10
Project Investigator(s): Sylvain Perret
Sponsor: International Rice Research Institute IRRRI
Total Contracted Amount (THB): 160,000

4.12.4 On-going Grants and Sponsored Research

4th Batch of E- Learning Program on Integrated Water Resources Management

Duration: 01 Sep 09 - 31 Dec 11
Project Investigator(s): Mukand S Babel
Sponsor: UNU-INWEH and participants
Total Contracted Amount (THB): 878,000

Assistance in developing a Trainers Manual on Integrated Watershed Management on the basis of the MRC-GTZ Watershed Management Projects experiences and materials

Duration: 01 Jul 10 - 30 Jun 11
Project Investigator(s): Mukand S Babel
Sponsor: RECOFTC Thailand
Total Contracted Amount (THB): 418,500

Climate Change and Adaptation to water Scarcity: Strategies for integrated water and land use management to enhance the resilience of rural communities in the Gangetic Basin

Duration: Feb 2010- Jan 2012
Project Investigation: Dr. Sangam Shrestha
Sponsor: Institute for Global Environmental Strategies (IGES)
Total Contracted Amount (THB): 500,000

Climate change Impacts on Seasonally and Intermittently Open Tidal Inlets

Duration: 01 Jan 10 - 31 Dec 13
Project Investigator(s): Sutat Weesakul
Sponsor: UNESCO-IHE
Total Contracted Amount (THB): 953,540

Establishment of Overseas Collaboration center at AIT

Duration: 01 Jun 10 - 30 May 11
Project Investigator(s): Sangam Shrestha
Sponsor: ICRE University of Yamanashi Japan
Total Contracted Amount (THB): 701,592

Estimation of water foot print and virtual water flow related to agricultural products in Nepal

Duration: 01 Sep 10 - 31 Aug 11
Project Investigator(s): Sangam Shrestha
Sponsor: Center for Research for Environment Energy and Water (CREEW) Nepal
Total Contracted Amount (THB): 142,000

Life Cycle Assessment of export Rice and Cotton in South-South East Asia

Duration: 07 Jan 10 - 30 Jun 12
Project Investigator(s): Sylvain Perret
Sponsor: SDCC AIT France Network
Total Contracted Amount (THB): 1,440,000

Optimization of water allocation between off stream and in stream competing demands

Duration: 01 Sep 09 - 30 Aug 11
Project Investigator(s): Mukand S Babel
Sponsor: UNESCO-IHE Delft Netherlands
Total Contracted Amount (THB): 1,430,680

Physical Hydraulic Model study of Xayaburi Hydroelectric Power project Lao PDR

Duration: 01 May 09 - 31 Jan 11
Project Investigator(s): Sutat Weesakul
Sponsor: Ch. Karnchang Public co.Ltd
Total Contracted Amount (THB): 7,450,000

Post Doctoral Research Programme on Adaptation to Climate change (PProACC) in River Basin Development

Duration: 01 Apr 10 - 30 Mar 12
Project Investigator(s): Mukand S Babel
Sponsor: UNESCO-IHE Delft Netherlands
Total Contracted Amount (THB): 1,933,800

Post Doctoral Research Programme on Adaptation to Climate change (PProACC) in Water Resources Management and Governance

Duration: 01 Apr 10 - 30 Mar 12
Project Investigator(s): Mukand S Babel
Sponsor: UNESCO-IHE Delft Netherlands
Total Contracted Amount (THB): 1,504,800

Support to Capacity Building at the Water Resources University, Hanoi, Vietnam

Duration: 01 Sep 01 -31 May 13
Project Investigator(s): Mukand S. Babel, Ashim Das Gupta
Sponsor: Danish International Development Assistance (Danida)
Total Contracted Amount (THB): 3,801,000

Training Course on Irrigation Systems and Hydraulic Structures for Participants from Afghanistan

Duration: 01 Nov 10 - 31 Oct 11
Project Investigator(s): Mukand S Babel
Sponsor: DAI,ACDI/VOCA, USA
Total Contracted Amount (THB): 2,039,820

Training Course on IWRM Practices

Duration: 01 Oct 08 -30 Sep 11
Project Investigator(s): Mukand Babel (71%), Robert Clemente (29%)
Sponsor: DWI, BAPPENAS (State Ministry of National Development Planning/National Development Planning Agency), Indonesia
Total Contracted Amount (THB): 6,232,347

4.12.5 Publications

International Journal Articles with Impact factor

Ashim Das Gupta, Mukand S. Babel, Ashrafi S.. Effect of soil texture on the emission characteristics of porous clay pipe for subsurface irrigation. *Irrigation Science*, 3(27) 0-0, 2010.

Babel, M. S., Rivas, A. A. and S. Kallidaikurichi (2010). Municipal Water Supply Management in Bangkok: Achievements and Lessons, *International Journal of Water Resources Development*, 26(2), 193-217.

Bandaragoda, D. J. and **M. S. Babel** (2010). Institutional Development for IWRM: An International Perspective, *International Journal of River Basin Management*, 8(3&4), 215-224.

Chapagain S.K., Pandey V.P., Sangam Shrestha, Nakamura T., Kazama F.. Assessment of deep groundwater quality in kathmandu valley using multivariate statistical techniques. *Water, Air, and Soil Pollution*, 1-4(210) 0-0, 2010.

Dang, N. M., **Babel, M. S.** and H. T. Luong (2010). Evaluation of Flood Risk Parameters in the Day River Flood Diversion Area, Red River Delta, Vietnam, *Natural Hazards*. DOI: 10.1007/s11069-010-9558-x.

Del Mundo Dacera D., Mukand S. Babel, Preeda Parkpian. Potential for land application of contaminated sewage sludge treated with fermented liquid from pineapple wastes. *Journal of Hazardous Materials*, 1-3(167) 0-0, 2010.

Desalegn, Ch. E., **Babel, M. S.**, and A. Das Gupta (2010). Drought Analysis in the Awash River Basin, Ethiopia, *Water Resources Management*, 24 (7), 1441-1460.

Donjadee S., Roberto S. Clemente, Tawatchai Tingsanchali, Chinnarasri C.. Effects of vertical hedge interval of vetiver grass on erosion on steep agricultural lands. *Land Degradation and Development*, 3(21) 0-0, 2010.

Edossa D.C., Mukand S. Babel, Ashim Das Gupta. Drought analysis in the Awash River Basin, Ethiopia. *Water Resources Management*, 7(24) 0-0, 2010.

Ghimire Y.N., Ganesh P. Shivakoti, Sylvain Roger Perret. Household-level vulnerability to drought in hill agriculture of Nepal: Implications for adaptation planning. *International Journal of Sustainable Development and World Ecology*, 3(17) 0-0, 2010.

Hung N.Q., Mukand S. Babel, Sutat Weesakul, Nitin K. Tripathi. An artificial neural network model for rainfall forecasting in Bangkok, Thailand. *Hydrology and Earth System Sciences*, 8(13) 0-0, 2010.

Keokhumcheng, Y., Tingsanchali, T., and **Clemente, R.** 2010. Flood risk assessment in the eastern region of Bangkok floodplain, Central Thailand. Paper submitted and under review in the *Water International Journal*.

Khan N.M., Tawatchai Tingsanchali. Optimization and simulation of reservoir operation with sediment evacuation: A case study of the Tarbela Dam, Pakistan. *Hydrological Processes*, 5(23) 0-0, 2010.

Khattak, M. S., **Babel, M. S.** and M. Sharif (2010). Hydro-meteorological Trends in Upper Indus River Basin in Pakistan, *Climate Research*, doi :10.3354/cr 00957.

Manandhar S., Dietrich Schmidt-Vogt, Sylvain Roger Perret, Kazama F.. Adapting cropping systems to climate change in Nepal: a cross-regional study of farmers' perception and practices. *Regional Environmental Change*, () 0-0, 2010.

Mark, O., J. O. Lacoursiere, L. B-M. Vought, Amena, Z., and **M. S. Babel** (2010). Application of Hydroinformatics Tools for Water Quality Modeling and Management: Case Study of Vientiane, Lao P.D.R., *Journal of Hydroinformatics*, 12(2), 161-171.

Mukand S. Babel, Buchel B., Tucci C.L.. The performance impact of intra-firm organizational design on an alliance's NPD projects. *Research Policy*, 8(38) 0-0, 2010.

Mukand S. Babel, Islam Md.S., Ashim Das Gupta. Leakage management in a low-pressure water distribution network of Bangkok. *Water Science and Technology: Water Supply*, 2(9) 0-0, 2010.

Mukand S. Babel, Jensen J.R.. Regional workshop on water saving irrigation practices in rice-based canal systems, Bangkok, Thailand, 8-9 october 2009. *International Journal of Water Resources Development*, 3(26) 0-0, 2010.

Mukand S. Babel, Rivas A.A., Kallidaikurichi S.. Municipal water supply management in Bangkok: Achievements and lessons. *International Journal of Water Resources Development*, 2(26) 0-0, 2010.

Mukand S. Babel, Sae-Tang J., Pecharaply A.. Anaerobic co-digestion of sewage and brewery sludge for biogas production and land application. *International Journal of Environmental Science and Technology*, 1(6) 0-0, 2010.

Mullick, M. R. A., **Babel, M. S.** and **S. R. Perret** (2010). Discharge-based Economic Valuation of Irrigation Water: Evidence from the Teesta River, Bangladesh. *Irrigation and Drainage*. DOI: 10.1002/ird.597.

Pandey V.P., Mukand S. Babel, Kazama F.. Analysis of a Nepalese water resources system: Stress, adaptive capacity and vulnerability.

Water Science and Technology: Water Supply, 2(9) 0-0, 2010.

Pandey, V. P., **Babel, M. S., Shrestha, S.** and F. Kazama (2010). Vulnerability of Freshwater Resources in Large and Medium Nepalese River Basins to Environmental Change. *Water Science and Technology*, 61(6), 1525-1534.

Pandey, V. P., **Babel, M. S., Shrestha, S.**, and F. Kazama (2010). A Framework to Assess Adaptive Capacity of Water Resources System in Nepalese River Basins, *Ecological Indicators*. doi:10.1016/j.ecolind.2010.07.003

Pensuk, A., Shrestha, R., and **Clemente, R.** Effect of Land Use Change on Land Quality and Water Resources in Phattalung Watershed, Thailand. 2010. IJERD – International Journal of Environment and Rural Development March 2010 pp 158-163.

Pinthong P., Ashim Das Gupta, Mukand S. Babel, Sutat Weesakul. Improved reservoir operation using hybrid genetic algorithm and neurofuzzy computing. *Water Resources Management*, 4(23) 0-0, 2010.

Pongsai, S., Schmidt-Vogt, D., Shrestha, R., **Clemente, R.**, and Aphisit, E. 2010. Calibration and validation of MUSLE for estimating sediment yield on sloping plots: A case study in Khun Satan catchment of Northern Thailand. *Canadian Journal of Soil Science* 90:585-596.

S. Shrestha, Y. Kataoka, and T. Kuyama (2010). No-Regret Adaptation Strategies to Cope with Potential Impacts of Climate Change on Groundwater Resources of Asian Cities. In: *Sustainability in Food and Water: An Asian Perspective* (K. Fukushi, K.M. Hassan, R. Honda and A. Sumi eds.), Springer, New York. ISBN: 978-90-481-9913-6

S.K. Chapagain, V.P. Pandey, S. Shrestha, T. Nakamura, and F. Kazama. (2010). Assessment of deep groundwater quality in Kathmandu Valley using multivariate statistical techniques. *Water, Air, & Soil Pollution*, 210 (1-4):277-288.

Sharma, D., **Babel, M. S.**, and V. K. Srivastava (2010). An Approach to Efficient Rainwater Management for Agriculture in Arid Region of Rajasthan, India, *International Journal of Water Resources and Environmental Management*, 1(1), 39-52.

Singhratna N., Mukand S. Babel, Sylvain Roger Perret. Hydroclimate variability and its statistical links to the large-scale climate indices for the Upper Chao Phraya River Basin, Thailand. *Hydrology and Earth System Sciences Discussions*, 5(6) 0-0, 2010.

Sutat Weesakul, Rasmeemasuang T., Tasaduak S., Thaicharoen C.. Numerical modeling of crenulate bay shapes. *Coastal Engineering*, 2(57) 0-0, 2010.

Thongsaga, K., Ranamukhaarachchi, S.L., Jampatong, S., Samarakoon, L., Noomthorn, A., **Clemente, R.** and Hannaway, D. 2010. Comparison of crop simulation and field performance of maize under 20-day dry period during selected critical growth periods in Nakhon Ratchasima Province, Thailand. *Recent Research in Science and Technology Journal*.2010, 2(5):17-31

Tiewtoy, S., **Clemente, R. S., Perret, S. R., Babel, M. S. and S. Weesakul** (2010). Irrigation Sustainability Assessment of Selected Projects in Tha Chin Basin, Thailand, *Irrigation and Drainage*. DOI10.1002/ird.583.

V.P. Pandey, M. S. Babel., **S. Shrestha** and F. Kazama (2010). A framework to assess adaptive capacity of water resources system in Nepalese river basins, *Ecological Indicators* (Available online, DOI:

10.1016/j.ecolind.2010.07.003 , Manuscript No .ECOLIND-939R2)

V.P. Pandey, **S. Shrestha** and F. Kazama (2010) Estimation of Groundwater Storage Potential in Kathmandu Valley Aquifers Using GIS Technique. In: *5th IWA Young Water Professionals Conference (YWPC2010)*, 5-7 July, The University of New South Wales, Sydney, Australia.

Vongvisessomjai, N., **Tingsanchali, T.** and **M. S. Babel** (2010). Non-deposition Design Criteria for Sewers with Part-full Flow, *Urban Water Journal*, 7(1), 61–77.

Wang G., Yu J., Sangam Shrestha, Ishidaira H., Takeuchi K.. Application of a distributed erosion model for the assessment of spatial erosion patterns in the Lushi catchment, China. *Environmental Earth Sciences*, 4(61) 0-0, 2010.

Wongsupap C., Sutat Weesakul, Clemente R., Ashim Das Gupta. River basin water quality assessment and management: Case study of Tha Chin River Basin, Thailand. *Water International*, 3(34) 0-0, 2010.

Y. Kataoka, Y and **S. Shrestha** (2010). Promoting Wise Use of Water: Application of Economic Instruments. In: *Sustainable Consumption and Production in the Asia-Pacific Region: Effective Responses in a Resource Constrained World*, Vol III, 2010. p149-170. Publisher: IGES (Hayama, Japan)

Refereed Books / Chapters

Babel, M. S., Islam M. S. and A. A. Rivas (2010). Application of Hydraulic Modelling for Leakage Management in the Bangkok Water Supply System - A Case Study, In Price, R.K. and Z. Vojinovic (2010). *Urban Hydroinformatics: Data, Models and Decision Support for Integrated Urban Water Management*, IWA Publishing, December, 2010.

Conference Proceedings

Babel, M. S., Agarwal, A. and S. Herath (2010). Impact of Climate Change on Rained Rice Yield in Northeast Thailand, In Herath, S., Yi, W., and Luohui, L (eds.) Proceedings of “Meeting Climate Change Challenges in Transboundary Basins: Role of Sciences”, UNU-ISP, CECAR series 4, 239-249.

Babel, M. S., Das Gupta, A., Nguyen, D. C. and S. Herath (2010). Operation of Hydropower System in La Nga River Basin, Vietnam with Environmental Flow Consideration, In Herath, S., Yi, W., and Luohui, L (eds.) Proceedings of “Meeting Climate Change Challenges in Transboundary Basins: Role of Sciences”, UNU-ISP, CECAR series 4, 193-201.

Dang, N. M and **M. S. Babel** (2010). Integrated Flood Risk Assessment for the Flood Diversion Area of the Red River, Vietnam. A presentation made at the GCOE-ARS Symposium and Workshop held at DPRI, Kyoto University, 12-14 January 2010.

Muangthong, S. and **Clemente R.** 2010. Preliminary assessment of ecological health of Lower Songkhran wetland, Thailand. Proceedings of the International Conference on Wetland Ecosystem Services: Biodiversity, Livelihoods and Sustainability. Khon Kaen, Thailand. Nov. 17-21, 2010

Shrestha, B., **Babel, M. S.,** and **S. R. Perret** (2010). Evaluating the impact of biofuel production on watershed hydrology using SWAT. In: Proceedings of 2010 International SWAT Conference, 4-6 August 2010. Seoul, South Korea.

Toufiq, A., **Clemente, R., Babel, M. S.** and Donjatee, S. 2010. Evaluation of Porous Pipe for Sustainable Irrigation. Paper submitted/accepted for presentation at the IASTED International Conference on

Environmental Management and Engineering (EME 2010) in Banff, Alberta, Canada. July 15-17 2010

4.12.6 Doctoral Students' Dissertation

An Integrated Approach to Irrigation System Assessment and Management of Selected Projects in Tha Chin Basin, Thailand

By Sanidda Tiewtoy
Supervisor: Dr. Roberto S. Clemente

Development and Application of Self-Cleansing Design Criteria for Sediment Transport in Sewer Networks

By Natchapon Vongvisessomjai
Supervisor: Dr. Mukand Singh Babel

Integrated Water Resources Management

Rainfall Forecasting and Real Time Hydrologic Information System for Bangkok, Thailand

By Nguyen Quang Hung
Supervisors: Dr. Mukand S. Babel/Dr. Nitin Kumar Tripathi

4.12.7 Masters Students' Theses and Research Studies

Adaptation to Extreme Flooding Scenarios in Colombo under Climate Change Conditions

By Malawara Arachchige Chamila Niroshinie
Supervisor: Dr. Mukand S. Babel

Analysis of the Effect of Mangrove (Rhizophora Apiculata) on Tsunami Force Reduction

By Panupong Tharaphoom
Supervisor: Dr. Sutat Weesakul

Analysis of the Effects of Mangrove in Mitigating Tsunami Inundation: A Simulation Study at Ban Nam Khem, Thailand

By Poonchai Nuntakomol
Supervisors: Dr. Roberto S. Clemente / Dr. Sutat Weesakul

Analysis of Water Quality under Climate Change Scenarios for Saigon River System, Vietnam

By Tran Nguyen Thien An
Supervisor: Dr. Mukand S. Babel

An Investigation of Water Supply Services in Kashgar City, Xinjiang, The People's Republic of China

By Abudujiapaer Yusufu
Supervisors: Dr. Mukand S. Babel / Dr. Sutat Weesakul

Application of Aquacrop for Simulating Crop Yield Response to Water in Puok District, Siem Reap, Cambodia

By Chek Chenda
Supervisor: Dr. Roberto S. Clemente

Application of Deficit Irrigation Concept in Huai Theien Project, Kanchanaburi, Thailand

By Ekapong Gatethong
Supervisor: Dr. Roberto S. Clemente

Application of LCA and Virtual Water Approaches to Assess the Environmental Impacts of Rice Production

By Satish Dhondur Rahatwal
Supervisors: Dr. Sylvain Roger Perret / Dr. Mukand S. Babel

Assessing the Impact of Sea Level Rise in Hai Phong Coastal Zone Vietnam: Mapping and Economic Valuation of Damages

By Vu Quoc Anh
Supervisor: Dr. Sylvain Roger Perret

Assessment of Domestic Water Consumption from a Socioeconomic Perspective in Kandahar, Afghanistan

By Abdul Tawab Balakarzai
Supervisors: Dr. Mukand S. Babel / Dr. Sylvain Roger Perret

Assessment of Future Climate and its Impact on Streamflow: A Case Study of Bagmati Basin, Nepal

By Shyam Prasad Bhusal
Supervisor: Dr. Mukand S. Babel

Assessment of People's Vulnerability to Existing Rural Water Supply System: The Case of Argao Municipality, Philippines

By Ryan Bulaquia Laytani
Supervisor: Dr. Roberto S. Clemente

Asset Management of Water Infrastructure: Case Study of Swa Irrigation System in Myanmar

By Kyaw Swa Myint
Supervisor: Dr. Roberto S. Clemente

Climate Change Impact on Coastal Hydrology of Pak Phanang River Basin, Thailand

By Donpapob Manee
Supervisor: Dr. Mukand S. Babel

Design Storm Pattern for Monsoon Region

By Jirayu Kontoengern
Supervisors: Dr. Roberto S. Clemente / Dr. Sutat Weesakul

Evaluation of Porous Pipe Irrigation for Growing Corn

By Ahmad Toufiq
Supervisor: Dr. Roberto S. Clemente

Experimentation for the Improvement of Sediment Flushing at Xayaburi Dam

By Santti Panyasombat
Supervisors: Dr. Mukand S. Babel / Dr. Sutat Weesakul

Impact of Biofuel Production on Tropical Watershed Hydrology: A Case Study of Khlong Phlo Basin in Thailand

By Bikesh Shrestha
Supervisors: Dr. Mukand S. Babel / Dr. Sylvain Roger Perret

Impact of Climate Change in Hydrology and Water Resources in the Case of Kabul Basin Afghanistan

By Ramin Mehri
Supervisor: Dr. Mukand S. Babel

Rainfall and Runoff Forecasting: A Case Study in the Tha Ta Pao River Basin, Thailand

By Rasu Suepsahakarn
Supervisor: Dr. Mukand S. Babel

Rainfall Forecasting for Bangkok Using Weather Radar Images

By Weerawat Ittipanyakul
Supervisors: Dr. Mukand S. Babel / Dr. Sutat Weesakul

Simulation of Cyclone-Induced Flooding in Myanmar

By Moh Moh Khaing
Supervisor: Dr. Mukand S. Babel

Simulation of Rainfed Rice Yields Under Climate Change in Puok District, Siem Reap Province, Cambodia

By Thoeung Puthearum
Supervisor: Dr. Sylvain Roger Perret

Research Study: An Investigation of Drought and Wheat Production in Hari Rod River Basin, Afghanistan

By Mohammad Wasim Iqbal
Supervisor: Dr. Roberto S. Clemente



4.13: SET – INFORMATION AND COMMUNICATIONS TECHNOLOGIES AREA OF STUDY

4.13.1 Introduction

Information and Communications Technologies field is a newly established area of study in response to the needs for the offering of a curriculum selectively drawn from the curricula of Telecommunications (TC), Computer Science, and Information Management (CSIM). With strong emphasis on communications aspects - rather than on the aggregation of hardware, software, networks, equipment and related industries - ICT recognizes the important role of information services and applications in the creation of a complete ICT infrastructure.

4.13.2 Research Facilities and Laboratories

There is a rapidly growing and constantly evolving interest in ICT throughout the academia and society. To support this, the evolution and the benefits of ICT in our lives, the ICT field of study at AIT continues to research and develop of ICT. The field of study covers a wide variety of research supported by the body of faculty consisting of a multi-professional team of international experts in telecommunication, computer science, educational technology and related fields.

The faculty has a strong academic background ranging from wireless and optical networks, through hardware and software, to web education and other e-services.

Research subjects include those on ICT applications (e-services such as e-learning, e-health, e-governance, rural development, knowledge creation and knowledge dissemination); on the information technologies (e.g. operating systems, programming languages, information storage and retrieval); on the

communication infrastructure (e.g. networks, transmission technologies, switching and routing). Research specializations are in adaptive technologies; computer-supported collaboration; Home networking; ICT security; online communities; and voice over IP.

The ICT area of study shares the research facilities and laboratories of the Telecommunications field of study.

4.13.3 Faculty and Research Staff

The ICT Field of Study draws from the faculty and research staff of the Computer Science, Information Management, Remote Sensing & Geographic Information Systems, and Telecommunications Fields of Study.

From ICT Area of Study

MIKKO KOVALAINEN, Ph.D.,
M.Econ., University of Jyväskylä,
Finland

Visiting Senior Researcher

From Telecommunications Field of Study

KAZI MOHIUDDIN AHMED, **Professor**
R M A P RAJATHEVA, **Associate**

Professor, ICT-Joint Coordinator

TEERAPAT SANGUANKOTCHAKORN,
Associate Professor

POOMPAT SAENGUDOMLERT,
Assistant Professor

TAPIO ERKE, **Visiting Associate**
Professor

From Computer Science and Information Management Fields of Study

KANCHANA KANCHANASUT,
Professor

PETER HADDAWY, **Professor**

PHAN MINH DUNG, **Professor**
VILAS WUWONGSE, **Professor**
SUMANTA GUHA, **Associate**
Professor

VATCHARAPORN ESICHAIKUL,
Associate Professor

MATTHEW N. DAILEY, **Assistant**
Professor

PAUL JANECEK, **Assistant Professor,**
ICT Joint Coordinator

From Remote Sensing and Geographic Information Systems Field of Study

KIYOSHI HONDA, **Associate**
Professor

NITIN KUMAR TRIPATHI, **Associate**
Professor

XIAOYONG CHEN, **Associate**
Professor and ICT Joint
Coordinator

4.13.4 Masters Students' Theses and Research Studies

A Case Study of Designing a New E-Learning Environment for the Royal University of Bhutan

By Sonam Penjor

Supervisor: Dr. Mikko Petri Kovalainen

Access Network Resource Allocation Through Utility Maximization for a Delay-Sensitive Traffic

By Karin Ngamkajornvivat

Supervisor: Dr. Poompat Saengudomlert

A Disaster Data Management System Using Linked Open Data

By A.Thushari Priyangika Silva

Supervisor: Prof. Vilas Wuwongse

A New Approach for QoS Provision Based on Multi-Constrained Feasible Path Selection in Manet OLSR Protocol

By Padam Maharjan

Supervisor: Dr. Teerapat Sanguankotchakorn

Cognitive and Relay Networks: Power Allocation and Beamforming

By Karaputugala G.A.M. Thilina
Supervisor: Dr. R.M.A.P. Rajatheva

Developing an Organizational Process Mining Plug Within a Framework

By Sengly Leng
Supervisor: Dr. Sumanta Guha

Epidemic Dissemination of Event Information on Optimized Link State Routing Protocol (OLSR)

By Wattanadej Jutacharoensuk
Supervisor: Dr. Teerapat Sanguankotchakorn

Finding Best Expert for Tutoring in Haptic Based Dental Simulator

By Poonam Shrestha
Supervisor: Prof. Peter Haddawy

Identifying Peer Researchers Through Publication Analysis

By Surendra Sedhai
Supervisor: Prof. Peter Haddawy

Integration of Delay Tolerant Network Approach on Mobile Ad Hoc Network

By Rujjipol Virochpoka
Supervisor: Dr. Teerapat Sanguankotchakorn

Mashup Applications for End Users: A Framework and User Acceptance Analysis

By Sirsha Bhattarai
Supervisor: Dr. Teerapat Sanguankotchakorn

Service Level Agreement (SLA) and Ontology for Online Contracting in Electricity

By Aye Pwint Aung
Supervisor: Prof. Phan Minh Dung

Social Network Service for a Mobile Ad Hoc Network

By Preechai Mekbungwan
Supervisor: Prof. Kanchana Kanchanasut

Spectrum Sharing in Overlay and Underlay Paradigms for Cognitive Communication Improvements

By Kapuruhamy B.S. Manosha
Supervisor: Dr. R.M.A.P. Rajatheva

Technology Challenges for Context Aware Multimedia Services

By Suneth Namal Karunarathna
Supervisor: Dr. R.M.A.P. Rajatheva

The Cross Layer Framework for Efficient MPEG-4 Video Streaming Over IEEE 802.11e EDCA

By Kumar Pudashine
Supervisor: Dr. Teerapat Sanguankotchakorn

Web Forum Mining Based on User Satisfaction

By Suresh Pokharel
Supervisor: Dr. Sumanta Guha

Research Study: Analysis of Real-Time Information Dissemination Using Hybrid Push-Pull Mode

By Deepika Rai
Supervisor: Prof. Phan Minh Dung

Research Study: An ITIL -based Framework for Building and Managing a Large-Scale CMDB

By Ngassa Fassa Tresor
Supervisor: Dr. Paul Janecek

Research Study: A Speech Act Based Representation and Analysis of Social Network Protocols

By Sweta Pandey
Supervisor: Prof. Phan Minh Dung

Research Study: A Study of Comparative Performance Between 3G-LTE and Wimax Networks

By Nguyen Minh Thu
Supervisor: Prof. Kazi Mohiuddin Ahmed

Research Study: Business Intelligence for Predicting Consumer Price Index

By Bastien Bonneton
Supervisor: Dr. Vatcharaporn Esichaikul

Research Study: Monitoring Outsourced IT Services: A Case of E-mail Service Outsourcing

By Aye Sandy Myint
Supervisor: Prof. Phan Minh Dung

Research Study: Performance Comparison of AODV Routing Protocol in Homogeneous and Heterogeneous Manets

By May Myint Htwe
Supervisor: Dr. Teerapat Sanguankotchakorn

Research Study: Performance Comparison of OLSR Routing Protocol in Homogeneous and Heterogeneous Manets

By Thein Tun Aung
Supervisor: Dr. Teerapat Sanguankotchakorn

Research Study: Performance Study of Cascade Algorithm for Information Reconciliation in Quantum Key Distribution

By Gouri Rani Barai
Supervisor: Dr. Poompat Saengudomlert

Research Study: Protection Against Link Failures in WDM Networks Using P-Cycles: A Case Study of Lao Telecom

By Manoxay Detchanthachuck
Supervisor: Dr. Poompat Saengudomlert

Research Study: Routing and Wavelength Assignment in Optical Networks with Sparse Wavelength Conversion

By Thiengtham Keopasith
Supervisor: Dr. Poompat Saengudomlert

Research Study: Strategic Decision for Transition to 4G Networks

By Frederic Leduc
Supervisor: Prof. Kazi Mohiuddin Ahmed

Research Study: The Role of Microblogging in Emergency Management: A Case Study of Twitter

By Albane Coeurquétin
Supervisor: Dr. Sumanta Guha

Research Study: Traffic Measurement and Analysis of Mobile Ngn Network: A Case Study of ETL, Laos

By Sangvan Chanthachone
Supervisor: Dr. Tapio J. Erke

Research Study: Web-Based Support System for Contract Dispute Resolution

By Suwiphar Suwatthanaphiset
Supervisor: Prof. Phan Minh Dung

4.14: SET – OFFSHORE TECHNOLOGY AND MANAGEMENT PROGRAM

4.14.1 Introduction

Rationale

Oil and Gas resources in the Southeast Asian region have been explored for several decades, especially following the global slump in oil and gas production during the early 1970's. Since then, the region has become one of the most productive oil and gas areas in the world. However, the global demand for skilled human resources of the upstream oil and gas industry greatly exceeds the supply and, therefore, regional companies are required to seek contract overseas worker to fill job vacancies; a situation that continues to exist after more than three decades of E&P activity in the region. The shortage of skilled manpower has recently become critical due to the tremendously high level of oil and gas exploration and production activity around the world that has occurred to meet the increasing global demand for energy, especially since China's becoming the "world's factory", and the move towards deep water exploration and production.

Mission Statement

AIT's Offshore and Technology & Management Program (OTM) is the first of its kind to provide regional post-graduate study in upstream oil and gas education, and is designed to combine application-oriented course work, field studies and internships into a curriculum from which graduates are equipped with the skills and knowledge-and-practice-readiness to mitigate the shortages of skilled manpower in the upstream sector of oil and gas industry. As an industrial application-oriented program, OTM's unique characteristics offer a flexible

study structure which allows students to build their own area of specialization in addition to the areas formally offered in the program, those areas being: Offshore Structural Design and Construction (OSDC), Oil and Gas Management (OGM), and Geosystem Exploration and Petroleum GeoEngineering (GEPG, and offered in collaboration with the Geotechnical and Geoenvironmental field of study). With the available teaching expertise; library and laboratory facilities; multitude of courses from AIT's different schools; skilled and professional faculty members and staff; strong collaborations with overseas partner universities in Europe, Asia, Australia and North America; and strongly supported by oil and gas industries, AIT's OTM post-graduate program has become one of the most suitable post-graduate study for engineers and young managers to pursue higher professional careers in both the oil and gas industry and government bodies.

4.14.2 Faculty and Research Staff

Full-time Faculty

GREGORY L.F. CHIU, M.S. Civil Engineering, Columbia University, New York, USA; PhD. Civil Engineering, Stanford University, California, USA

Visiting Associate Professor

Adjunct Faculty

JOKO HARSONO WIDJAJA, Master of Engineering, Asian Institute of Technology, Bangkok, Thailand; Doctor of Philosophy, University of Technology, Sydney-NSW, Australia

L.F. BOSWELL, Doctor of Philosophy, University of Leeds; Doctor of Science, Technical University of Isai; Doctor of Science, Technical University of Cluj Napoca

POOVADOL SIRIRANGSI, Master of Business Administration, University of Central Oklahoma the United State; Doctor of Engineering, Asian Institute of Technology, Bangkok, Thailand

PORNONG ASAVADORNDEJA, Master of Engineering, Asian Institute of Technology, Bangkok, Thailand; Doctor of Engineering, Asian Institute of Technology, Bangkok, Thailand

PRATEEP POKINWONG, Master of Science, University of Southern California, USA; Doctor of Philosophy in Engineering, University of Southern California

SARUNPHONG ARTICHARTE; Master of Science, Texas A&M University, USA

THITISAK BOONPRAMOTE, Master of Science, Colorado School of Mines, USA; Ph.D., Colorado School of Mines, USA

WINAI OUYORNPRASERT, Master of Engineering, Chulalongkorn University, Bangkok, Thailand; Ph.D., University of Innsbruck, Austria

4.14.3 Ongoing / In Progress Grant and Sponsored Research

Preparation of the Structural Assessment Guideline for Offshore Petroleum Platform and Pipeline

Duration: 29 Dec 07 - 31 Dec 11

Project Investigator(s): Worsak Kanok-Nukulchai, Joko Widjaja

Sponsor: Department of Mineral Fuel, Thailand
Total Contracted Amount (THB): 3,774,000

4.14.4 Publications

International Journal Article with Impact factor

Ferdinand E. Banks. Economic theory and some aspects of the new world oil market. *Geopolitics of Energy*, 3(31) 0-0, 2010.

4.14.5 Masters Students'

Theses and Internships

A Comprehensive Articulated Stinger Optimization Study

By Mr. Surapluek Menkham
Supervisor: Dr Gregory L. F. Chiu

A Diagnostic Model for Non-Productive Wells and Probable Solutions

By Mike Bamidele Iwayemi
Supervisor: Dr. Gregory L. F. Chiu

An Appropriate Fea Modeling Technique for On-Bottom Roughness Analysis

By Witcha Leepipatpaiboon
Supervisor: Dr. Gregory L. F. Chiu

Cost and Practical-Based Concept for an Innovative Design of Minimum Offshore Structures

By Jitrada Buacharoen
Supervisors: Dr. Gregory L. F. Chiu / Dr. Joko Harsono Widjaja

Enhancing Hydrocarbon Production from Gas-Condensate Reservoirs via Water Injection

By Usa Chankhiao
Supervisor: Dr. Gregory L. F. Chiu

Improved Gas-Lift Optimization Using Portfolio Theory

By Piyawat Tungtakul
Supervisor: Dr. Gregory L. F. Chiu

Optimal Inspection/Replacement Policy for Oil and Gas Production Facilities: A Case of Gas Compression and Treatment System

By Kullamas Udomkijja
Supervisors: Dr. Gregory L. F. Chiu / Dr. Poovadol Sirirangsi

Optimization of Offshore Pile Foundation Design

By Ahmadu Babaji Babadidi
Supervisor: Dr. Gregory L. F. Chiu

Petroleum Fiscal Regime Analysis for Timor-Leste: The Case of State-Owned Enterprise Participation

By Vicente Da Costa Pinto
Supervisors: Dr. Gregory L. F. Chiu / Dr. Thitisak Boonpramote

Response of a Derrick Barge Subjected to Surface Wave Generated by Underwater Explosion

By Nattawat Boonma
Supervisor: Dr. Gregory L. F. Chiu

Riser Protection Against Attendant Vessel Collision for a Steel Fixed Platform in the Gulf of Thailand

By Kris Tantiwimonkit
Supervisors: Dr. Gregory L. F. Chiu / Dr. Pornpong Asavadorndeja

Safety and Reliability of a Fixed Offshore Platform in the Gulf of Thailand

By Sakrit Charoenpornpanich
Supervisor: Dr. Gregory L. F. Chiu

Sensitivity Study for RSR of Fixed Offshore Steel Type Platforms

By Pattaradanai Pueksap-anan
Supervisors: Dr. Gregory L. F. Chiu / Dr. Joko Harsono Widjaja

Well Logging Interpretation for Jasmine Field with Emphasis on Water Saturation Evaluation

By Wattanaporn Phaophongklai
Supervisor: Dr. Pham Huy Giao

Internship: Decommissioning of Offshore Facilities

By Jongrak Naluang
Supervisor: Dr. Gregory L. F. Chiu

Internship: Free-Span Analysis of Offshore Pipeline

By Athip Danthainum
Supervisors: Dr. Gregory L. F. Chiu / Dr. Poovadol Sirirangsi

Internship: Offshore Oil and Gas Field Development Planning

By Zaw Htun
Supervisor: Dr. Gregory L. F. Chiu

Internship: Offshore Subsea Pipelines Inspection and Commissioning

By Kyaw Swar Linn
Supervisor: Dr. Gregory L. F. Chiu

Internship: Offshore Wind Turbine Support Structures

By Nisachol Nimdech
Supervisor: Dr. Gregory L. F. Chiu

Internship: Project Investment Decision

By Piriya Jammuang
Supervisor: Dr. Gregory L. F. Chiu

Internship: Underwater Robotics Technology in the Oil and Gas Industry

By Pongsak Methethara
Supervisor: Dr. Gregory L. F. Chiu

Chapter 5: SCHOOL OF ENVIRONMENT, RESOURCE AND DEVELOPMENT

5.1.1 Mission, Vision, and Core Values

SERD Mission

The School of Environment, Resources and Development is committed to excellence in graduate education as well as research and outreach activities. Through its academic programs and outreach units, SERD has been working towards capacity building and human resource development in the areas of resource management, development studies, and energy and environmental management.

SERD responds to regional needs by mobilizing and enhancing capacities for socially, economically and environmentally sound development in partnerships with public and private sectors. The School's interdisciplinary approach integrates technological, natural and social sciences.

SERD Vision

SERD will continue its leadership role in offering excellent academic programs relevant to regional needs.

SERD research will be concentrated toward focal areas and are to be conducted by core teams.

SERD outreach will be community service-oriented.

SERD Programs will be consolidated and financially viable. The School activities including the students, staff, faculty and curricula, will be subject to quality assessment.

SERD Core Values

- Interdisciplinarity
- Innovativeness
- Excellence
- Responsiveness

5.1.2 Field of Study and Multidisciplinary Programs

Fields of Study

- Agricultural Systems and Engineering
- Aquaculture and Aquatic Resources Management
- Energy
- Environmental Engineering and Management
- Food Engineering and Bioprocess Technology
- Gender and Development Studies
- Natural Resources Management
- Pulp and Paper Technology
- Regional and Rural Development Planning
- Urban Environmental Management

Inter-university Program

- Environmental Toxicology, Technology and Management

Interdisciplinary Programs

- Cleaner Production
- Agri Business Management
- Sustainable Development
- Disaster Prevention, Mitigation and Management
- Gender, Transportation and Development

5.1.3 Research Facilities and Laboratories

SERD provides laboratory, computer and information technology (IT) facilities for education and learning for graduate students, and research activities of graduate students, faculty, and sponsored and contracted projects.

SERD has six research laboratories in Agricultural Systems and Engineering, Aquaculture and Aquatic Resources Management, Food Engineering and Bioprocess Technology, Environmental Engineering and Management,

Energy, and Pulp and Paper Technology, and each laboratory is unique with modern equipments, excellent guidance and assistance, and provides safe working facilities and environments to carry out experimental studies and research.

IT facilities are provided for everyone to attend their academic and research related activities. There are three computer centers maintained by the SERD at the SERD Main building (two computer laboratories), Agriculture and Food Engineering building and Energy Building which provides convenient working environment, with all the necessary facilities. These are open twenty four hours a day for use by students, staff and faculty. Full internet access is available to these PCs through a high speed network backbone which connects all academic buildings including the residence halls. A large number of PC software packages for applications such as word-processing, spreadsheets, network communications, multimedia and file transfer utilities are available. High quality laser printers, scanning and CD writing facilities are available for students' uses.

Furthermore, laboratories also have computer facilities, which enhance the

productivity of the teaching and research activities of the school.

5.1.4 School Governance

Dean of School

WEERAKORN ONGSAKUL
BEng, Chulalongkorn Univ, Thailand;
MS, PhD, Texas A&M Univ, USA.

Associate Professor (*Artificial Intelligence Applications to Power Systems; Parallel Processing Applications; Power System Operation & Control; Power System Deregulation & Restructuring*)

Associate Deans

MOKBUL MORSHED AHMAD
BSc, MSc, Dhaka Univ, Bangladesh;
MSc, AIT, Thailand; PhD, Univ of
Durham, UK.

Associate Professor (*Economic geography; regional and rural development planning; community development; Non-Governmental Organizations (NGOs); civil society; globalization etc*)

ANIL KUMAR ANAL, DVM., University
of Agriculture, Pakistan; MSc. and
PhD., AIT, Thailand

Assistant Professor (Food
Engineering & Bioprocess
Technology Field of Study)

*(Animal Biotechnology, Food and
Pharmaceutical Biotechnology,
Dairy and Meat Process
Technology, Food Colloids and
Biopolymer, Functional Foods,
Micro-/Nanoencapsulation,
Bionanotechnology)*

5.1.5 On-going Grants and Sponsored Research

Greater Mekong Sub region Academic and Research Network

Duration: 20 Apr 10 - 19 Apr 11
Project Investigator(s): Weerakorn Ongsakul
Sponsor: Multi donors
Total Contracted Amount (THB): 1,000,000

5.2 SERD – AGRICULTURAL SYSTEMS AND ENGINEERING FIELD OF STUDY



Precision spraying using a radio controlled quad-copter



Green house

5.2.1 Introduction

This field of study emphasizes on sustainable agricultural and related technologies development through holistic approach for efficient food production from small holder agriculture.

5.2.2 Research Facilities and Laboratories

Agricultural Systems and Engineering (ASE) Laboratory caters to researchers, which address sustainability in agricultural production. The facilities are capable for implementing excellent agronomic and engineering researches on soils, water and plant, such as, plant growth, soil fertility and management, integrated pest management, plant water requirement, etc. Facilities to conduct researches on terramechanics, ergonomics and tillage are also available. The engineering aspects of agricultural production are dealt with through innovations and development of machines and equipment to enhance productivity and reduce human drudgery. These innovations are constructed at the ASE workshop.

Major laboratory equipment include a Spectro UV- VIS double PC double beam (scanning) flame photo meter; Digestion

block; Trinocular Microscope MBL 2100; Stereo zoom microscope Model MSZ 5400; Porometer type AP4 Light meter WP4 Dewpoint Potential Meter; Mini-disk Infiltrometer Soil hydraulic conductivity; Tensio Meter; Soil bin carriage system; Sony CXC- 390 1/3" 3 CCD Camera; Spider 8 data logger; National Instrument DAQ; NI Vision Module; Dynamic strain amplifier; and an SC-900 Soil compaction meter.

The SERD Computer Lab III in the Agricultural and Food Engineering Building has various kinds of software packages for system analysis and simulation, including DSSAT (Decision Support System for Agrotechnology Transfer), ArcView etc. A Computer-Aided Design (CAD) workstation is also available for training the design of agricultural equipment. There is a machine workshop with facilities for fabricating various types of laboratory and experimental apparatus and models. Consultation and fabrication of different types of transducers can be provided. About 20 high-end PCs connected to the campus-wide Ethernet and ATM network and a high quality laser printer, scanning and CD writing facilities are available for students' uses.

5.2.3 Faculty and Professional Staff

Full-time Faculty

GANESH P SHIVAKOTI, BS, MS, Udaipur Univ, India; PhD, Michigan State Univ, USA.

Professor (*Agricultural Development and Policy Analysis; Resource Development; Farming Systems; Natural Resources Management*)

PEEYUSH SONI; DEng

Senior Instructor (*Instrumentation and Measurement Techniques; Design & Testing of Agricultural Machinery; Precision Agriculture; Analytical Techniques & Decision Tools for Agribusiness*)

Visiting, Adjunct and Affiliated Faculty

S L RANAMUKHAARACHCHI, BSc, Univ of Peradeniya, Sri Lanka; MSc, PhD, Pennsylvania State Univ, USA.

Visiting Associate Professor (*Agronomy; Crop Eco-physiology; Cropping Systems; Pest Management; Soil Fertility*)

*Management; Organic Farming;
Stress Physiology)*

PRABHAT KUMAR; B.Sc. (Ag. & Hons., RAU, India); M.Sc. (Ag. Systems, AIT); Dr.Rer.Hort. (Uni Hannover, Germany)

Senior Research Specialist and Affiliated Faculty (*Tropical Horticulture Production and Protection Systems, Integrated Pest Management, Extension Education and Communication, Applied and Action Research, Application of nano-technologies for Agriculture*)

ABHA MISHRA; B.Sc. (Ag.& Hons), RAU, India); M.Sc. (Ag.) Plant Breeding, RAU, Pusa, India; Ph.D. (Ag. Systems), AIT

Senior Research Specialist and Affiliated Faculty (*Agronomy; Agro-ecology, Conservation agriculture, Agriculture and Climate Change Adaptation*)

CHAIYAPHOL

KAEWPRAKAISAENGKUL; PhD

Adjunct Faculty (*Agricultural Machinery Design & Testing; Instrumentation & Measurement; Quality Control & Assurance*)

ROONGRUANG KALSIRISILP; PhD

Adjunct Faculty (*Agricultural Machinery Design & Testing; Agricultural Power & Machinery Management; Agricultural Systems Engineering*)

Professional Staff

WATTANAPORN MESKUNTAVON, DTechSc

Senior Laboratory Supervisor (*Crop Modeling; Farm Management; Laboratory Analyses of Soil and Plants*)

5.2.4 Grants and Sponsored Research Completed in 2010

Protected cultivation- An Approach to Sustainable Vegetable Production in Humid Tropics- Phase II

Duration: 01 Aug 04 - 30 Jun 10
Project Investigator(s): V. M. Salokhe/Peeyush Soni
Sponsor: Hannover University, Germany
Total Contracted Amount (THB): 10,000,000

Research Cooperation project (RC136) with Harper Adams University College, UK

Duration: Jan 08 – Dec 10
Project Investigator(s): V. M. Salokhe/Peeyush Soni
Sponsor: British Council – Prime Minister’s Initiative (PMI)-2 Research Cooperation project grant
Donor: British Council- PMI2
Total Contracted Amount (GBP): 22,113

5.2.5 On-going Grants and Sponsored Research

Area Wide Integrated Pest Management of Fruit Flies in South and Southeast Asian Countries

Duration: 15 Feb 10 - 30 Mar 12
Project Investigator(s): Prabhat Kumar
Sponsor: Global Horticulture Initiative Funding from ICDF, Taiwan
Total Contracted Amount (THB): 8,125,000

Commissioning and coordinating regional studies on Public-Private-Partnership (PPP) for Agribusiness and Agro-industry development in Asia

Duration: 01 Jan 10 - 31 Dec 11
Project Investigator(s): Peeyush Soni
Sponsor: FAO of the United Nations
Total Contracted Amount (USD): 46,500

Community preparedness for climate change and increased water use efficiency for rice cultivation using principles of SRI (System of Rice Intensification) in Central Thailand

Duration: 01 May 2009- 31 March 2011
Project Investigator(s): Abha Mishra, Prabhat Kumar
Sponsor: United Nations Environment Programme (UNEP)’s Asia Pacific Forum for Environment and Development (APFED)
Total Contracted Amount (THB): 1,020,000

Less Loss more Profit better Health: Reducing the losses caused by the Pod borer on Vegetable legumes in SE Asia and Sub Saharan Africa by refining

component technologies of a sustainable management strategy

Duration: 01 Aug 10 - 31 Jul 12
Project Investigator(s): Prabhat Kumar
Sponsor: AVDRC Taiwan
Total Contracted Amount (THB): 929,475

Linking Thai Jasmine Rice Farmers with Markets using Participatory action research for sustainability of rain-fed lowland rice-based system in Northeast Thailand

Duration: 01 Jan 08 - 31 Dec 11
Project Investigator(s): Abha Mishra, Prabhat Kumar, Sudip Rakshit
Sponsor: Consultative Group on International Agricultural Research CGIAR World Bank
Total Contracted Amount (THB): 8,262,000

Regional knowledge exchange with SRI: Producing more with less water

Duration: 01 Jun 09 - 30 Jun 11
Project Investigator(s): Abha Mishra, Prabhat Kumar
Sponsor: World Bank Institute
Total Contracted Amount (THB): 1,426,300

Short Term Training in ASE Agricultural engineering

Duration: 01 Jul 10 - 31 Dec 11
Project Investigator(s): Peeyush Soni
Sponsor: Sultan qaboos University (SQU) Oman
Total Contracted Amount (THB): 62,863

5.2.6 Publications

International Journal Articles with Impact factor

Abha Mishra, Vilas M. Salokhe. Rice root growth and physiological responses to SRI water management and implications for crop productivity. *Paddy and Water Environment*. DOI: 10.1007/s10333-010-0240-4. Published online (early view -22 December 2010) by springerlink. *Impact factor: 1.03*

Abha Mishra, Vilas M. Salokhe. The effects of planting pattern and water regime on root morphology, physiology and grain yield of rice. *Journal of Agronomy and Crop Science*, 196, 368-378, 2010. *Impact factor: 2.28*

Azam M.G., Michael Zoebisch, Wickramarachchi K.S., Ranamukarachchi S.L.. Site-specific soil hydraulic quality index to

describe the essential conditions for the optimum soil water regime.

Canadian Journal of Soil Science, 5(89) 0-0, 2010.

Bastakoti R.C., Ganesh P. Shivakoti, Lebel L.. Local irrigation management institutions mediate changes driven by external policy and market pressures in Nepal and Thailand. Environmental Management, 3(46) 0-0, 2010.

Doi R., S. L. Ranamukhaarachchi. Community-level physiological profiling in monitoring rehabilitative effects of acacia auriculiformis plantation on degraded land in Sakaerat, Thailand. Silva Fennica, 5(43) 0-0, 2010.

Doi R., S. L. Ranamukhaarachchi. Correlations between soil microbial and physicochemical variations in a rice paddy: implications for assessing soil health.. Journal of biosciences, 6(34) 0-0, 2010.

Doi R., S. L. Ranamukhaarachchi. Soil dehydrogenase in a land degradation-rehabilitation gradient: Observations from a savanna site with a wet/dry seasonal cycle. Revista de Biologia Tropical, 1-2(57) 0-0, 2010.

Ghimire Y.N., Ganesh P. Shivakoti, Sylvain Roger Perret. Household-level vulnerability to drought in hill agriculture of Nepal: Implications for adaptation planning. International Journal of Sustainable Development and World Ecology, 3(17) 0-0, 2010.

Karna B.K., Ganesh P. Shivakoti, Edward L. Webb. Resilience of community forestry under conditions of armed conflict in Nepal. Environmental Conservation, 2(37) 0-0, 2010.

Khumsri M., Ruddle K., Ganesh P. Shivakoti. Rights and conflicts in the management of fisheries in the Lower Songkhram River Basin, Northeast Thailand. Environmental Management, 4(43) 0-0, 2010.

Kumar, P., H.P. Singh, and, H.-M. Poehling. 2010. Effects of neem on adults *Eretmocerus warrae* (Hym., Aphelinidae), a parasitoid of *Bemisia tabaci* (Hom., Aleyrodidae) in the tropical horticulture systems. Journal of Plant Diseases and Plant Protection. 117 (6), 273–277, 2010. Impact factor: 0.56.

Lungkapin J., Vilas M. Salokhe, Roongruang Kalsirisilp, Nakashima H.. Design and development of a cassava planter. Transactions of the ASABE, 2(52) 0-0, 2010.

Mahdi, Ganesh P. Shivakoti, Dietrich Schmidt-Vogt. Livelihood change and livelihood sustainability in the uplands of Lembang subwatershed, West Sumatra, Indonesia, in a changing natural resource management context. Environmental Management, 1(43) 0-0, 2010.

Nalavade P.P., Vilas M. Salokhe, Tanya Niyamapa, Peeyush Soni. Performance of Free Rolling and Powered Tillage Discs. Soil and Tillage Research, 2(109) 87-93, 2010. Elsevier. Impact factor: 2.883

Nalavade P.P., Vilas M. Salokhe, Tanya Niyamapa. Strain node identification by FEM and measurement of disc forces by double extended octagonal ring transducer. Journal of Food, Agriculture and Environment, 2(8) 0-0, 2010. Impact factor: 0.35

Sanjeevanie Ginigaddara G.A., S. L. Ranamukhaarachchi. Effect of conventional, SRI and modified water management on growth, yield and water productivity of direct-seeded and transplanted rice in central Thailand. Australian Journal of Crop Science, 5(3) 0-0, 2010. Swain K.C., Thomson S.J., Hemantha P. W. Jayasuriya. Adoption of an unmanned helicopter for low-altitude remote sensing to estimate yield and total biomass of a rice crop. Transactions of the ASABE, 1(53) 0-0, 2010.

Ting Z., Haiyun C., Ganesh P. Shivakoti, Roland Cochard, Homchaim K.. Revisit to community forest in northeast of Thailand: changes in status and utilization. Environment, Development and Sustainability, () 0-0, 2010.

5.2.7 Doctoral Students' Dissertation

Exploration of Potential Microbial Antagonists for the Biological Management of Spot Blotch Disease (Bipolaris sorokiniana) in Wheat
By Deepak Bhandari
Supervisor: Dr. S. L. Ranamukhaarachchi

Modeling Soil and Powered-Disc Interactions for the Development of a Powered-Disc Harrow
By Parish Prakash Nalavade
Supervisor: Dr. Peeyush Soni

5.2.8 Masters Students' Theses

Analysis of Irrigated Farming System Prospected for Tuv and Selenge Provinces in Mongolia
By Sodgerel Volodya
Supervisor: Prof. Ganesh P. Shivakoti

Assessing and GIS Mapping of Climate Change Effects on Major Plantation Crops in Sri Lanka and Application of Existing Crop Models
By P.M.S. Jayathilaka
Supervisor: Dr. Peeyush Soni

Assessment of Land Productivity and Socio-Economic Aspects of Maize-Based Cropping Systems: A Case Study in Dry Zone and Hilly Regions in Myanmar
By Mae Suu Han
Supervisor: Dr. S. L. Ranamukhaarachchi

Biological Control of Bacterial Wilt Disease Caused by Ralstonia solanacearum in Tomato with Candida ethanolica and Enterobacter cloacae by Modifying Carbohydrate Source and Soil PH
By Hengodage Nirmalee Bhagya Wijayalath
Supervisor: Dr. S. L. Ranamukhaarachchi

Causes of the Recurrence of Brown Planthopper (Nilaparvata lugens Stal) Epidemic in Rice and its Control Measures in the Suphan Buri Province, Thailand

By Mayuree Yasueb

Supervisor: Dr. S. L. Ranamukhaarachchi

Comparative Studies of Biological and Physical Methods for Effective Control of Anthracnose Disease Caused by

Colletotrichum Gloeosporioides in Mango

By Myat Su Tun

Supervisor: Dr. S. L. Ranamukhaarachchi

Development of a Low-Cost Sugarcane Harvester

By Suvischar Arsarnok

Supervisor: Dr. Peeyush Soni

Effects of Packing Material and Storage Temperature and Benzyladenine Pulsing on Vaselife of Gerbera (Gerbera jamensonii Var. "Carmen" Bol. Ex Adlam) Cut Flowers Pre-treated with Silver Thiosulphate and Sucrose

By Dinanjana Chavindi Ekanayake

Supervisor: Dr. S. L. Ranamukhaarachchi

Energy Analysis of Rice Production in Central Plain of Thailand: A Case Study from Suphanburi Province

By Vatinee Mongkolluk

Supervisor: Dr. Peeyush Soni

Modeling Tractive Performance of Cage Wheels by Dimensional Analysis Technique

By Vikramsinh Sampatrao Shinde

Supervisor: Dr. Peeyush Soni

Simulation of Haulage Performance of Agricultural Tractors Using Visual Basic

By Bharat Devaba Pawar

Supervisor: Dr. Peeyush Soni

5.3: SERD – AQUACULTURE AND AQUATIC RESOURCES MANAGEMENT FIELD OF STUDY

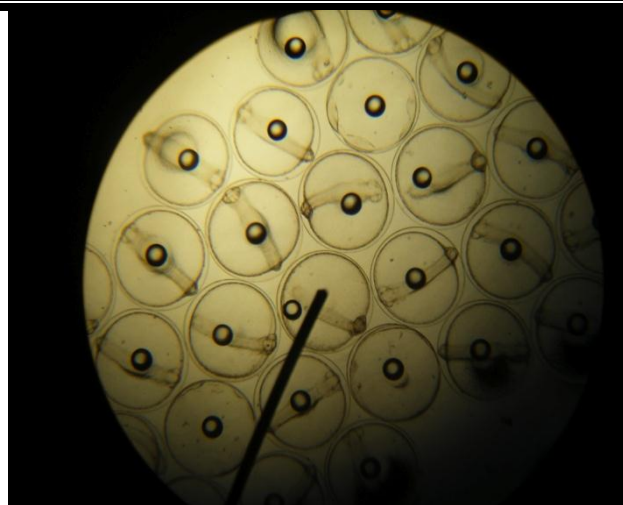

5.3.1 Introduction

AARM promotes research and development through aquaculture and small-scale capture fisheries. The Field of Study has a wide spectrum of activities enabling it to address poverty, constraints facing the promotion of sustainable management and utilization of aquatic resources. The central theme is capacity building: the advancement of individuals and institutions creating indigenous capacity in education, research and development within the region.

5.3.2 Research Facilities and Laboratories

Aquaculture Laboratory serves the academic and research programs of aquaculture and aquatic resources management (AARM) field of study. It is equipped with modern equipment to analyze water quality, nutrients in food and feedstuffs, and soil classification and their problems identification. Some of its major laboratory equipment includes a Distillation Unit; Extraction Unit; Incubator; UV/Vis Spectrophotometer; Soxtec, Fibertec and Kjelttec system, microscope with camera, etc. The field facilities include a hatchery, outdoor

tanks and earthen ponds for field research.

The SERD Computer Lab III in the Agricultural and Food Engineering Building has various kinds of software packages for system analysis and simulation, including DSSAT (Decision Support System for Agrotechnology Transfer), ArcView etc. A Computer-Aided Design (CAD) workstation is also available for training the design of agricultural equipment. There is a machine workshop with facilities for fabricating various types of laboratory and experimental apparatus and models. Consultation and fabrication of different types of transducers can be provided. About 20 high-end PCs connected to the campus-wide Ethernet and ATM network and a high quality laser printer, scanning and CD writing facilities are available for students' uses.

5.3.3 Faculty and Research Staff

Emeritus Professor

PETER EDWARDS, BSc, University of Liverpool, UK; PhD, University of Texas, USA.

(General aquaculture with emphasis on recycling organic wastes (human, animal,

agro-industrial); small-scale aquaculture; integrated farming; aquaculture for poverty alleviation; and systems approaches to education, research and development; curriculum development; project formulation, management and evaluation.

Full-time Faculty

AMARARATNE YAKUPITIYAGE, BSc, Univ of Kelaniya, Sri Lanka; MSc, AIT, Thailand; PhD, Univ of Stirling, Scotland.

Associate Professor
(Aquaculture, Bioenergetics, Fish Nutrition, Statistics, Database Systems Development)

AMRIT BART, BA Earlham College, USA; MA, MS, PhD, Auburn Univ, USA.

Associate Professor *(Aquatic Resource Management, Cryopreservation, Reproductive Physiology, Seed Production)*

WENRESTI G GALLARDO, BSc, Master of Aquaculture, University of the Philippines; MSc, PhD, Nagasaki University, Japan;

Associate Professor
(Aquaculture - Seed Production and Grow-out, Fisheries)

Management, Integrated Coastal Management)

Research Staff and Affiliated Faculty

DHIRENDRA P. THAKUR, BfSc, Rajendra Agricultural University, India; MSc, AIT, Thailand; MSc, Kochi University, Japan; PhD, Ehime University, Japan;

Senior Research Specialist and Affiliated Faculty (*Intensive aquaculture, Water quality and nutrient dynamics, Environmental impacts of aquaculture; Integrated Coastal Management, Aquatic product quality and certification*)

RAM C. BHUJEL, BSc, Institute of Agriculture and Animal Sciences, IAAS, Chitwan, Nepal; MSc and PhD, AIT, Thailand;

Senior Research Scientist and Affiliated Faculty (*Biostatistics and Research Design, Curriculum Development, Women in Aquaculture, Broodstock Nutrition/Management and Fry Production, Technology Transfer/ Extension*)

5.3.4 Grants and Sponsored Research Completed in 2010

AIT Support to NUOL: 2007-2010 Curriculum Development-Fisheries

Duration: 01 Jun 10 - 31 Dec 10
Project Investigator(s): Wenresti G Gallardo, Amaratne Yakupitiyage
Sponsor: SIDA
Total Contracted Amount (THB): 1,075,866

5.3.5 On-going Grants and Sponsored Research

AIT-Coca Cola for Sustainable Coastal Livelihoods Project in Ranong Province, Thailand

Duration: 01 Oct 05 - 31 Mar 12
Project Investigator(s): Amrit N. Bart
Sponsor: Coca Cola (Thailand) Ltd.
Total Contracted Amount (THB): 8,000,000

Ecosystem Level impacts of Shrimp farm Eutrophication in Thailand

Duration: 01 Jun 09 - 28 Feb 11
Project Investigator(s): Dharendra Prasad Thakur
Sponsor: University of Michigan
Total Contracted Amount (THB): 620,160

Integrated culture of tropical abalone (*Haliotis asinina*) seaweed (*Ulva sp.*) rock oyster (*Saccostrea cuculata*) and sea bass (*Lates calcarifer*) in land based recirculation system

Duration: 01 Aug 09 - 31 Mar 11
Project Investigator(s): Wenresti Gallardo
Sponsor: RTG
Total Contracted Amount (THB): 950,000

International Symposium on Aquaculture and Fisheries Education

Duration: 01 Mar 09 - 28 Feb 11
Project Investigator(s): Wenresti Gallardo, Ram C Bhujel
Sponsor: Multi donors
Total Contracted Amount (THB): 2,481,600

Internship in Aquaculture and Aquatic Resources Conservation

Duration: 01 Sep 10 - 31 Aug 11
Project Investigator(s): Ram C. Bhujel
Sponsor: Multi donors
Total Contracted Amount (THB): 3,000,000

Linking the Post-graduate Education in Aquaculture and Aquatic Resources Management with its Industry Through Internship

Duration: 01 Sep 07 - 28 Feb 11
Project Investigator(s): Ram C. Bhujel
Sponsor: European Commission
Total Contracted Amount (THB): 31,939,965

Sustainable Aquaculture Research Networks in Sub-Saharan Africa

Duration: 01 Feb 08 - 31 Jan 11
Project Investigator(s): Ram C. Bhujel
Sponsor: European Commission through University of Stirling, UK
Total Contracted Amount (THB): 3,000,010

5.3.6 Publications

Journal

Ahmad S.A.S., Bart A.N., Yang Yi, Rakocy J., Diana J.S., (2010). The effect of the introduction of Nile tilapia (*Oreochromis niloticus*, L.) on small indigenous fish species (mola, *Amblypharyngodon mola*, Hamilton; chela, *Chela cachius*, Hamilton; punti, *Puntius sophore*, Hamilton). *Aquaculture Research*, 6(41) 0-0.

Doma D., Yakupitiyage A. (2010). A policy alternative for lagoon management: case study of Sre Ambel coastal marine fisheries, Cambodia. *Journal of Coastal Conservation*. (in press).

Ioannis T., Karapanagiotidis, I.T., Yakupitiyage A., Little D.C., Bell M. V. and Mente E. (2010) The nutritional value of lipids in various tropical aquatic animals from rice–fish farming systems in northeast Thailand, *Journal of Food Composition and Analysis* 1(23) pp. 1–8

Islam M.S., Ikejima K. (2010). Gear type, species composition and economic value of fisheries in the mangroves of Pak Phanang, Thailand. *Wetlands Ecology and Management*, 1(18) pp.27-36, 2010.

Muangkeow, B., Ikejima, K., Powtongsook, S., Gallardo, W.G. (2010). Growth and nutrient conversion of white shrimp *Litopenaeus vannamei* (Boone) and Nile tilapia *Oreochromis niloticus* L. in an integrated closed recirculating system. *Aquaculture Research* (in press).

Peatpisut T and Bart A.N., (2010). Cryopreservation of sperm from natural and sex reversed orange-spotted grouper (*Epinephelus coioides*). *Aquaculture Research*. 42:22-30.

Sikawa, D. C. and Yakupitiyage, A. (2010) The hydroponic production of lettuce (*Lactuca sativa* L) by using hybrid catfish (*Clarias macrocephalus* x *C. gariepinus*) pond water: potentials and constraints, *Agricultural Water management*, 97(9): 1317 – 1325.

Silakes S. and Bart A.N. (2010). Ultrasound enhanced permeation of methanol into zebrafish, *Danio rerio*, embryos. *Aquaculture* 303: 71-76.

Son V.N., Phuong N.T., Hai T.N. and **Yakupitiyage A.** (2010) Production and economic efficiencies of intensive black tiger prawn (*Penaeus monodon*) culture during different cropping seasons in the Mekong delta, Vietnam. *Aquaculture International*. Published online: 17 September 2010. pp.1-12.

Thakur D.P., Yang Yi., Boromthanasarat S., Tansakul V., (2010). Effluent management practices and harvest draining associated mass discharge from shrimp farms in Chachaengsao, Thailand. *Asian Fisheries Science*, 23: 270-283.

Yuan, D., Yang Yi, **A. Yakupitiyage**, Fitzimmons, K. and Diana J. S. (2010) Effects of addition of red tilapia (*Oreochromis* spp.) at different densities and sizes on production, water quality and nutrient recovery of intensive culture of white shrimp (*Litopenaeus vannamei*) in cement tanks. *Aquaculture* 3-4(298) pp. 226–238

Conference/workshop proceedings

Bhujel, R.C. (2010). On–farm feed management practices for Nile tilapia (*Oreochromis niloticus*) in Thailand. FAO Expert Consultation Workshop on On-farm Feeding and Feed Management in Aquaculture, 13-15 September 2010. Manila, Philippines.

Bhujel, R.C. (2010). Links that matter: Recurring themes in EU-Asian Higher Education Cooperation, Part III: Sustainability of EU-Asian academic collaboration: 8. Financial sustainability - Aqua-Internship: A Model for Financially Sustainable Academic Collaboration. NUFFIC, DAAD, UEA, EU.

Kempke S., Diana J.S., **Thakur D.P.** (2010). Investigating Ecosystem-level impacts of shrimp farm eutrophication in Thailand through stable isotope ratio analysis, and an evaluation of eco-certification's potential to support related best management practices. In the book

of abstracts of the AQUACULTURE 2010 WAS Conference and Exposition, March 1-5, San Diego, California, USA, pp. 516.

Thakur D.P. (2010). Climate change impacts on aquaculture and fisheries. Paper presented at the “Indian Aqua-Invest Congress and Expo-2010” (Invited speaker), May 26-28, Central Institute of Fisheries Education, Mumbai, India.

Thakur D.P., Bergheim A. (2010). Experimental trail for the liquid oxygen injection system to aerate commercial intensive shrimp culture ponds. In the book of abstracts of the AQUACULTURE 2010 WAS Conference and Exposition, March 1-5, San Diego, California, USA, pp. 997.

Thakur D.P., Gallardo W.G., Bart A.N., (2010). Climate change impacts and community level adaptations: a case study on marine shrimp farming in Thailand. In the book of abstracts of the “International Symposium on Coastal Zones and Climate Change: Assessing the Impacts and Developing Adaptation Strategies, April 12-13, Monash University Gippsland, Churchill, Victoria, Australia, pp. 24-25.

Yakupitiyage A. (2010) Potential climate change induced impacts on aquaculture in the Lower Mekong Basin: The challenges and opportunities. In “Meeting climate change challenges in transboundary basins: Role of sciences”, S. Herath, Y. Wang and L. Liang (eds.) CECAR series No.04, United Nations University, p 261 – 275.

Yakupitiyage A. (2010) Paper presented at FAO Expert Workshop Report on “On-farm feeding and feed management in aquaculture” held in Manila, Philippines, from 13 - 15 September 2010. In FAO Fisheries and Aquaculture Report No. 949 “Report of the FAO workshop on the on-farm feeding and feed

management in Aquaculture (FIRA/R949).

5.3.7 Doctoral Students' Dissertation

An Evaluation of Potential Development of a Catfish-Lettuce Aquaponic Culture System

By Daniel Clement Sikawa
Supervisor: Dr. Amaratatne Yakupitiyage

Assessment of the Status of Marine Fisheries Resources and Management Practices in Sre Ambel Lagoon, Cambodia

By Dok Doma
Supervisor: Dr. Amaratatne Yakupitiyage

Ecological and Socio-Economic Assessment of Thai Andaman Coast in Designing a Marine Protected Area Network

By Md. Zakir Hossain
Supervisor: Dr. Nitin K. Tripathi

Effect of Introducing the Nile Tilapia (Oreochromis niloticus) on the Small Indigenous Fish Species of Bangladesh and Nepal

By Sultanul Arifin Shameem Ahmad
Supervisor: Dr. Amrit Bart

Mangrove Community Forest Management Tools for Sustainable Mud Crab Resource Use in Trang Province, Southern Thailand

By Chanyut Sudtongkong
Supervisor: Dr. Edward Webb

5.3.8 Masters Students' Theses and Research Studies

A Comparative Study of Energy Partitioning of TRA Catfish (Pangasius hypophthalmus) Fed Farm-Made and Commercial Feeds

By Tran Le Cam Tu
Supervisor: Dr. Amaratatne Yakupitiyage

A Feasibility Study of Small Scale Soy Protein Concentrates (SPC) Production and its Use as a Feed Ingredient for Nile Tilapia (Oreochromis niloticus) Juveniles

By Nyakorema Beatrice Marwa
Supervisor: Dr. Amaratatne Yakupitiyage

Assessment of the Effects of Fenobucarb on Acetylcholinesterase Activity and

Growth of Silver Barb *Puntius gonionotus* (Bleeker, 1850)

By Ha Phu Loi

Supervisor: Dr. Amaratne Yakupitiyage

Bacterial Population in Intensive Tilapia (*Oreochromis niloticus*) Culture Pond Sediments in Hai Duong Province, Vietnam

By Ngo Thi Thanh Huong

Supervisor: Dr. Wenresti Gallardo

Characterization of Microsatellite Loci and Genetic Structure of Cutler *Alburnus* in China

By Nguyen Thi Thanh Truc

Supervisor: Dr. Amrit Bart

Effects of Different Feeding Regimes Weaning Period and Stocking Density on Survival and Growth of Spotted Featherback Fish Fry (*Chitala ornata*)

By Sirisopa Munsiri

Supervisor: Dr. Amaratne Yakupitiyage

Evaluation of Adopted Best Management Practices in Shrimp Farming in Sri Lanka Using Life Cycle Assessment

By Keerthi Sri Senarathna Atapaththu

Supervisor: Dr. Amaratne Yakupitiyage

Evaluation of a Suitable Ingredient Composition for Supplementary Feeds of Nile Tilapia (*Oreochromis niloticus*) Grown in Fertilized Earthen Ponds

By Anthony Henry Dadu

Supervisor: Dr. Amaratne Yakupitiyage

Evaluation of Selected Pre-Processing Methods to Improve the Digestibility of Enzyme Treated Feather Meal and Enhance the Growth Performance of Nile Tilapia (*Oreochromis niloticus*)

By Sandamali Sakunthala Herath

Supervisor: Dr. Amaratne Yakupitiyage

Evaluation of the Potential for Development of an Integrated Land-Based Semi-Closed Recirculating Culture System

By Phung The Trung

Supervisor: Dr. Wenresti Gallardo

Participation of Local Fishers on Crab Banks in the Gulf of Thailand

By Pooritat Watcharasin

Supervisor: Dr. Wenresti Gallardo

Replacement of Fishmeal by Enzyme Treated Feather Meal by Supplementing Methionine and Lysine for Red Tilapia (*Oreochromis niloticus* x *O. mossambicus*)

By Arissara Sopawong

Supervisor: Dr. Amaratne Yakupitiyage

The Potential for Replacing Fishmeal Protein in Nile Tilapia (*Oreochromis niloticus*) Feeds by Using Mixtures of Plant Protein Sources

By Phan Thi Thanh Truc

Supervisor: Dr. Amaratne Yakupitiyage

The Use of Papaya (*Carica papaya*) Seed as an Alternative Method to Control the Reproduction of Nile Tilapia (*Oreochromis niloticus*)

By Yovita John Mallya

Supervisor: Dr. Wenresti Gallardo

Vulnerability of Coastal Shrimp Farmers to the Impacts of Climate Change: A Case Study of Marine Shrimp Farming in Pak Phanang District, Nakhon Sri Thammarat Province, Thailand

By Wiparat Taweewattana

Supervisors: Dr. Wenresti Gallardo / Dr. Dharendra Prasad Thakur

Research Study: Evaluating the Impacts of Lower Water Level in the Mekong River on the Livelihood of Fishermen in Southern Laos: A Case Study in Khong District, Champasack Province

By Vanny Sengkapkeo

Supervisor: Dr. Amaratne Yakupitiyage

5.4: SERD – ENERGY FIELD OF STUDY



5.4.1 Introduction

Energy related academic program at AIT was established in 1979. So far, over 1,000 students have graduated in the Energy studies. As of December 2009, about one hundred students are enrolled in Energy Field of Study. About thirty percent of the current students are at doctoral level. Apart from teaching and student research, faculty at Energy FoS is involved in a number of research projects. Some of the current research focuses of Energy FoS are Energy, environment and climate change, Energy for sustainable development, Renewable Energy and Energy efficiency, Electric power system management, and Energy economics and planning.

Student admitted to Energy Field of Study can specialize in one of the three areas.

- Electric Power System Management (EPSM)

- Energy Technology (ET)
- Energy Economics and Planning (EEP)

Details regarding Energy field of study activities are available at www.serd.ait.ac.th/energy

5.4.2 Research Facilities and Laboratories

Energy Laboratory serves as a facility for conducting experimental studies for courses, carrying out students and sponsored research, and testing of energy equipments as well as providing hands-on training. Laboratory functions are focused mainly on solar thermal energy, photovoltaics, biomass energy, energy management, thermodynamics and heat transfer, and electrical measurement and analysis. The laboratory facilities include two indoor laboratories, an energy park and a meteorological station. The indoor laboratories are equipped with experiment setups, testing apparatus and measuring equipment for thermal and

electrical management studies, thermodynamics, fluid mechanics and heat transfer, and electrical power supply management. Energy Park covers 3980- m^2 outdoor research and demonstration facility equipped with photovoltaic systems, solar thermal (air and water) systems, biomass research and daylighting setups. The meteorological station records solar radiation and other meteorological data. Energy laboratory continues to carry out testing services such as fuel quality tests, gas composition tests, tests for heating value of fuels, solar thermal collector performance tests, solar water heater system performance tests and stove efficiency tests.

Among its major equipment include a Gas Analyzer; Campbell data logger; Ultrasonic flow-meter; Bomb colorimeter; and a Gas chromatography.

The SERD Computer Lab IV in the Energy Building has a large number of computer modeling software for energy planning and policy analysis. These include Model

for Analysis of Energy Demand and Environmental Impacts (MAED, MEDEE-S/ENV, LEAP), Electricity System Planning (WASP-III Plus, ENPEP, DECPAC), Energy-Environmental Flow Optimization Model (EFOM-ENV), Wood Energy Planning Models, Energy-Environmental Models for estimation of impacts of energy externalities, air pollution emission and dispersion and climate change (CO2 DB, RAINS, TEMIC, ECOSENS, ISC) and Energy-Environmental Database Management Software (DBAVOID). An energy-environment database for Asia is maintained in this computer lab.

5.4.3 Faculty and Research Staff

Full-time Faculty

SAID IRANDOUST, MSc, PhD, Chalmers University of Technology, Sweden

Professor [Chemical reaction engineering]

SIVANAPPAN KUMAR, BE, Univ of Madras, India; MEng, AIT, Thailand; PhD, Inst Natl Polytechnique, Toulouse, France.

Professor [Renewable energy resources and technologies: Climate change and green house gas mitigation: energy and sustainable development]

WEERAKORN ONGSAKUL, BEng, Chulalongkorn Univ, Thailand; MS (EE), PhD, Texas A&M Univ, USA.

Associate Professor (Artificial Intelligence Applications to Power Systems; Parallel Processing Applications; Power System Operation & Control; Power System Deregulation & Restructuring)

P. ABDUL SALAM, BSc.Eng (Hons.) University of Peradeniya, Sri Lanka; M.Eng., D.Eng., AIT

Assistant Professor (Bioenergy, Renewable energy; Energy conservation and efficiency) ; Energy, environment and

climate change issues; Heat recovery systems)

JAI GOVIND SINGH, B.E., MNNIT Allahabad, India; M. Tech., Indian Institute of Technology Roorkee; Ph.D. in Electrical Engineering, Indian Institute of Technology, Kanpur, India

Assistant Professor (Power system planning; Operation and control; FACTS controllers; Restructuring of Electric Industry, Demand side management; Grid integration of renewable energy resources; Power distribution systems)

Visiting Faculty

BRAHMANAND MOHANTY, BSc, SAICE, India; MSc, AIT, Thailand; PhD, Institut National Polytechnique of Toulouse, France

Visiting Faculty [Cogeneration, Demand-side management, Energy auditing and conservation, Energy Efficiency policies; and Rational use of technology]

CHARLES O P MARPAUNG, B. Eng (E.E.) Bandung Institute of Technology, Indonesia, Ms.c, Statistics, Bogor Agricultural University, Indonesia; D. Eng, AIT

Visiting Faculty [Generation expansion planning; Energy economics and environmental modeling]

TRIPTA THAKUR, B.E. Electrical Engineering from MITS-Gwalior, India, M.Tech. Power Electronics and Drives, IIT Kanpur, Ph.D. Energy Policy Energy Studies, IIT Delhi, India.

Visiting Faculty [Energy Policy Economics Regulation and Benchmarking]

HUONG LUONG PHAM, B. Thermal Power Engineering, Hanoi University, Vietnam; M.Eng. Energy Technology, AIT; PhD. Process Engineering, Institut National Polytechnique de Toulouse, France.

Visiting Faculty [Energy Resources and Technology (fossil and renewable), Energy Conservation and Efficiency]

RAJESH KUMAR NEMA, B.E. Electrical Engineering, Barktulah University, Bhopal, India; M.E. Heavy Electrical Equipments, Barktulah University, Bhopal, India; Ph.D., Bhopal University, Bhopal, India.

Visiting Faculty [Power Electronics, Solar Photovoltaics, Distributed Generation and Power System]

Adjunct Faculty

RAM M SHRESTHA, BE, Univ of Baroda; LL Tribhuvan Univ, Nepal; MEng, DEng, AIT, Thailand.

Adjunct Faculty [Energy and Environmental Policy; Energy Economics; Energy-economic Modeling]

VO NGOC DIEU, B.Eng., MEng. Electrical Engineering, Ho Chi Minh City Univ of Technology, Vietnam, D. Eng. AIT.

Adjunct Faculty [Application of AI based method to power system optimization and power system deregulation and smart grid]

Research Staff

Mr. Abhinad Joshi, Research Associate (PDF funds – Prof. S. Kumar)

Mr. Albert Pedrajas, Program Officer (Sida - NUOL Project)

Mr. Apinat Saksinchai, Research Associate (Sida - NUOL Project)

Ms. Kanwalai Nachaisit, Secretary (GMSARN Project)

Ms. Manjula.T. Siriwardhana, Research Associate (GNESD, TNA mitigation Projects)

Ms. Maria Kathrina Gratuito, Research Associate (RERIC)

Ms. Merina S. Lohani, *Research Associate* (TNA – mitigation Project)

Ms. Nang Htay Yin, *Research Associate* (UNIDO Project)

Ms. Panida Boonyaritdachochai, *Research Associate* (Sida - NUOL Project)

Ms. Parichart Kammeerak, *Secretary* (RERIC)

Mr. Pravakar Pradhan *Research Associate* (ADEME Project)

Mr. Ramesh Soysa, *Research Associate* (GMSARN Project)

Ms. Sheree Ann Baywes-Mendoza, *Secretary* (ADEME, TNA – mitigation Project)

Ms. Shirina Afroze, *Research Associate* (TNA – mitigation Project)

Dr. Vo Ngoc Dieu, *Research Associate (Part time)* (GMSARN Project)

5.4.4 Grants and Sponsored Research Completed in 2010

AIT Support to NUOL: National Research Policy Development

Duration: 01 Dec 09 - 31 Dec 10
Project Investigator(s): S Kumar
Sponsor: SIDA
Total Contracted Amount (THB): 1,259,030

Bio-energy for Rural Development and Poverty Alleviation (BEN-RUD).

Duration: 15 February - 31 December 10
Project Investigator(s): Prof. Ram M. Shrestha and Prof. S. Kumar
Sponsor: GNESD, Denmark
Total contracted Amount: (THB) 866,750

Coordination Energy Security and Energy Efficiency Theme

Duration: 01 Jan 07 - 31 Dec 10
Project Investigator(s): S. Kumar
Sponsor: Global Network on Energy for Sustainable Development (GNESD)-UNEP RISO
Total Contracted Amount (THB): 320,000

E Learning Course on renewable Energy and energy Policy

Duration: 01 Nov 09 - 30 May 10
Project Investigator(s): S Kumar
Sponsor: UNESCO -Jakarta Office
Total Contracted Amount (THB): 408,000

Energy Security and Energy Efficiency Theme

Duration: 01 Jul 07 - 31 Jul 10
Project Investigator(s): Ram M. Shrestha, S. Kumar
Sponsor: Global Network on Energy for Sustainable Development (GNESD)-UNEP RISO
Total Contracted Amount (THB): 850,000

Green House gas emission mitigation at AIT: Reducing GHG Emission through Energy Conservation.

Duration: October 2009 – December 2010
Project Investigator(s): Prof. S. Kumar
Sponsor: AIT
Total contracted Amount: (THB)700,000

Networking with Norwegian and Regional Institutions in Energy Issues (South-South-North Networking): 2006-2009.

Duration: August 2006- June 2010
Project Investigator(s): Prof. S. Kumar and Dr. Weerakorn Ongsakul
Sponsor: Norwegian Ministry of Foreign Affairs
Total contracted Amount: (THB) 4,140,000

Pilot appraisal for Low Carbon technology innovation and diffusion in Thai Manufacturing services

Duration: 01 Nov 09 - Nov 2010
Project Investigator(s): S Kumar, C Visvanathan, P Abdul Salam,
Sponsor: UNIDO Austria
Total Contracted Amount (THB): 955,500

Regional workshop on "Opportunities and Priorities for Low carbon Green Growth in Asia"

Duration: 01 Sep 09 - 30 Aug 10
Project Investigator(s): S Kumar
Sponsor: ADB Japan
Total Contracted Amount (THB): 688,704

5.4.5 On-going Grants and Sponsored Research

Action Towards Resource Efficient and Low Carbon Cities in Asia

Duration: 01 Dec 09 - 28 Feb 12
Project Investigator(s): S Kumar, C Visvanathan, Ranjith Perera, P Abdul Salam, Charles Marpaung, Kyoko Kusakabe
Sponsor: ADEME (French Agency for Environment and Energy Management)
Total Contracted Amount (THB): 11,052,979

AIT Support to National University of Laos (NUOL), 2007-2010 Extension Research and Financial Management.

Duration: December 2010 – 31 December 2011
Project Investigator(s): Prof. S. Kumar
Sponsor: Sida
Total contracted Amount: (THB) 705,460

AIT Support to National University of Laos (NUOL), 2007-2010, Extension Self Assessment for the Cooperation Program.

Duration: December 2010 – 31 December 2011
Project Investigator(s): Prof. S. Kumar
Sponsor: Sida
Total contracted aAmount: (THB)787,450

Biomass gasification study in the Mekong Region

Duration: 01 Jun 10 – 28 February 2011
Project Investigator(s): Abdul Salam, S Kumar
Sponsor: EEP Mekong Region
Total Contracted Amount (THB): 617,000

Capacity Development on Clean Coal Technology and Carbon Sequestration

Duration: 1 April 2010– 1 October 2010
Project Investigator(s): Prof. S. Kumar
Sponsor: Southern States Energy Board, USA
Total contracted Amount: 514,696.55 Baht

EEP Mekong Regional Forum 2010

Duration: 01 Sep 10 - 31 Aug 12
Project Investigator(s): Weerakorn Ongsakul
Sponsor: EEP Mekong
Total Contracted Amount (THB): 1,537,820

Energy Efficiency using RETScreen Version 4.

Duration: 22 February 2010 – 31 May 2010
Project Investigator(s): Prof. S. Kumar and Dr. P. Abdul Salam
Sponsor: Sponsor: CANMET Energy Technology Center, Verenne, Canada
Total contracted Amount: (THB)162,600 (\$4,600 CAN)

Energy-Environmental Data Analysis for Low Carbon Society (EEDA).

Duration: 1 December 2009 – 31 March 2010
Project Investigator(s): Prof. Ram M. Shrestha and Prof. Kumar
Sponsor: MHIR (Mizhou)
Total contracted Amount: (THB)740,000

Energy Field of Studies Publications

Duration: 01 Jan 04 - 31 Dec 10
Project Investigator(s): S Kumar
Sponsor: membership fees, AIT
Total Contracted Amount (THB): 1,521,149

ICETT International Cooperation Network Information Project (ICNIP) in Thailand.

Duration: 1 September 2010 – 31 December 2010
 Project Investigator(s): Prof. S. Kumar
 Sponsor: Sponsor: International Center for Environmental Technology Transfer (ICETT), Japan
 Total contracted Amount: (THB) 230,000

Integration of RETScreen version 4 in education and training.

Duration: 22 February 2010 – 31 May 2010
 Project Investigator(s): Prof. S. Kumar and Dr. P. Abdul Salam
 Sponsor: Sponsor: CANMET Energy Technology Center, Verenne, Canada
 Total contracted Amount: 142,600 Baht (\$4,600 CAN)

International Conference on “Energy and Sustainable Development: Issues and Strategies (ESD 2010)

Duration: 01 Sep 09 - 30 Jun 11
 Project Investigator(s): Weerakorn Ongsakul, S. Kumar, Ram Shrestha
 Sponsor: Multi donors
 Total Contracted Amount (THB): 1,017,703

King HRD Scholarship Project.

Duration: 1 October 2009 – September 2013
 Project Investigator(s): Dr. Weerakorn Ongsakul
 Sponsor: EPPO
 Total contracted Amount: (THB):12,753,200

Low carbon cities: Learning from the experiences in France.

Duration: September 2010 – 31 December 2011
 Project Investigator(s): Investigator: Prof. S. Kumar, Prof. C. Visvanathan, Dr. P. Abdul Salam, Dr. Charles Marpaung, Dr. L.A.S. Ranjith Perera and Dr. Kyoko Kusakabe
 Sponsor: Sponsor: SDCC/AIT – France Network
 Total contracted Amount: (THB) 480,000

Micro Hydro PV Hybrid System

Duration: 01 Feb 10 - 01 Apr 12
 Project Investigator(s): S. Kumar, P. Abdul Salam, Jai Govind Singh, Charles Marpaung
 Sponsor: Ebara Katayama Memorial Fund Japan
 Total Contracted Amount (THB): 1,440,000

Provincial Electricity Authority (PEA)-AIT Cooperation Project.

Duration: January 2009 – December 2012
 Project Investigator(s): Dr. Weerakorn Ongsakul
 Sponsor: PEA
 Total contracted Amount: ((THB):27,374,000

Technology Needs Assessment in Asia and Europe for Climate Change Mitigation

Duration: 01 Jul 10 - 30 Apr 12
 Project Investigator(s): S. Kumar, Abdul Salam, Charles Marpaung
 Sponsor: UNEP Riso Center Denmark
 Total Contracted Amount (THB): 11,068,470

5.4.6 Publications

International Journal Articles with Impact factor

Adeel Waqar and S. Kumar, “Utilization of Latent Heat Storage Unit for Comfort Ventilation of Building in Hot and Dry Climates” *International Journal of Green Energy*, 2010 (accepted for publication).

B.R. Chavan, A. Yakupitiyage, S. Kumar, “Socio-Economic Analysis of Small-Scale Fisher Toward Coastal Fisheries Management for Rural Development in Maharashtra Coast, India, *Asia Pacific Journal of Rural Development*, Vol. XIX No. 2 pp. 45, December 2009.

Boonchai Rianguvilaikul and S. Kumar “A numerical study of a novel dew point evaporative cooling system” *Energy and Buildings*, Vol. 42, No. 11 pp. 1969-2268, 2010.

Boonchai Rianguvilaikul and S. Kumar “An experimental study of a novel dew point evaporative cooling system” *Energy and Buildings*, Vol. 42, No. xx, pp. 637-644, 2010.

Boonchuay C., Weerakorn Ongsakul. Optimal risky bidding strategy for a generating company by self-organising hierarchical particle swarm optimisation. *Energy Conversion and Management*, () 0-0, 2010.

Boonrit Prasartkaew and S. Kumar “A Low Carbon Cooling System Using Renewable Energy Resources and Technologies” *Energy and Buildings*, Vol. 42, No. 9, pp. 1453-1462, 2010.

Boonyaritdachochai P., Boonchuay C., Weerakorn Ongsakul. Optimal congestion management in an electricity market using particle swarm optimization with time-varying acceleration coefficients. *Computers and Mathematics with Applications*, 4(60) 0-0, 2010.

Chinsuwan A., Animesh Dutta. An experimental investigation of the effect of longitudinal fin orientation on heat transfer in membrane water wall tubes in a circulating fluidized bed. *International Journal of Heat and Mass Transfer*, 5-6(52) 0-0, 2010.

Chira Achayuthakan, Chris J. Dent, Janusz W. Bialek and Weerakorn Ongsakul “Electricity Tracing in Systems with and Without Circulating Flows: Physical Insights and Mathematical Proofs” *IEEE Transactions on Power Systems*, Vol. 25, No. 2, pp. 1078-1087, May 2010.

Duc Hien V., Surapong Chirarattananon. An experimental study of a facade mounted light pipe. *Lighting Research and Technology*, 2(41) 0-0, 2010.

J. Chandrasekaran, D. Nithyaprakash, K.B. Ajjan, S. Maruthanuthu, D. Mahoharan and S. Kumar, “Hybrid solar cell based on blending of organic and inorganic materials – An overview” *Renewable and Sustainable Energy Reviews*, 2010 (accepted for publication).

Jaojaruek K., Sivanappan Kumar. Numerical simulation of the pyrolysis zone in a downdraft gasification process. *Bioresource Technology*, 23(100) 0-0, 2010.

Katejanekarn T., Surapong Chirarattananon, Shailendra Kumar Shukla. An experimental study of a solar-regenerated liquid desiccant ventilation pre-conditioning system. *Solar Energy*, () 0-0, 2010.

Katejanekarn T., Surapong Chirarattananon, Sivanappan Kumar. An experimental study of a solar-regenerated liquid desiccant ventilation pre-conditioning system. *Solar Energy*, 6(83) 0-0, 2010.

Kerdchuen T., Weerakorn Ongsakul. Optimal measurement placement for security constrained state estimation using hybrid genetic algorithm and

- simulated annealing. *European Transactions on Electrical Power*, 2(19) 0-0, 2010.
- Mithulanathan Nadarajah. Influence of constant speed wind turbine generator on power system oscillation. *Electric Power Components and Systems*, 5(37) 0-0, 2010.
- Neelakantan Ramachandran, Nithyaprakash D., Ajjan K.B., n, Manoharan D., Sivanappan Kumar. Hybrid solar cell based on blending of organic and inorganic materials- An overview. *Renewable and Sustainable Energy Reviews*, () 0-0, 2010.
- Panida Boonyaritdachochai, Chanwit Boonchuay and Weerakorn Ongsakul "Optimal congestion management in an electricity market using particle swarm optimization with time-varying acceleration coefficients" *Computer and Mathematics with Applications*, Vol. 60 pp. 1068-1077, 2010.
- Prasartkaew B., Sivanappan Kumar. A low carbon cooling system using renewable energy resources and technologies. *Energy and Buildings*, () 0-0, 2010.
- Rabin Shrestha, Dietrich Schmidt-Vogt, Gnanavelrajah N.. Relating plant diversity to biomass and soil erosion in a cultivated landscape of the eastern seaboard region of Thailand. *Applied Geography*, 4(30) 0-0, 2010.
- Ram M. Shrestha and Salony Rajbhandari "Energy and environmental implications of carbon emission reduction targets: Case of Kathmandu Valley, Nepal" *Energy Policy*, Vol. 18 pp. 4818-4827, 2010.
- Ram M. Shrestha, Abeygunawardana A.M.A.K.. Evaluation of economic rent of hydropower projects. *Energy Policy*, 5(37) 0-0, 2010.
- Ram M. Shrestha, Gabriel Anandarajah, Liyanage M.H.. Factors affecting CO2 emission from the power sector of selected countries in Asia and the Pacific. *Energy Policy*, 6(37) 0-0, 2010.
- Ram M. Shrestha, Pradhan S.. Co-benefits of CO2 emission reduction in a developing country. *Energy Policy*, 5(38) 0-0, 2010.
- Ram M. Shrestha, Rajbhandari S.. Energy and environmental implications of carbon emission reduction targets: Case of Kathmandu Valley, Nepal. *Energy Policy*, 9(38) 0-0, 2010.
- Ram M. Shrestha, Rajbhandari S.. Energy and environmental implications of carbon emission reduction targets: Case of Kathmandu Valley, Nepal. *Energy Policy*, () 0-0, 2010.
- Rasul M.G., Tanty B.S., Brahmanand Mohanty. Erratum to Modelling and analysis of blast furnace for efficient utilization of energy [Applied Thermal Engineering 27 (2007) 78-88] (DOI:10.1016/j.applthermaleng.2006.04.026). *Applied Thermal Engineering*, 17-18(29) 0-0, 2010.
- Riangvilaikul B., Sivanappan Kumar. An experimental study of a novel dew point evaporative cooling system. *Energy and Buildings*, 5(42) 0-0, 2010.
- Riangvilaikul B., Sivanappan Kumar. Numerical study of a novel dew point evaporative cooling system. *Energy and Buildings*, 11(42) 0-0, 2010.
- Siriwardhana M., Opathella G.K.C., Mithilesh Kumar Jha. Bio-diesel: Initiatives, potential and prospects in Thailand: A review. *Energy Policy*, 2(37) 0-0, 2010.
- Vo Ngoc Dieu, Weerakorn Ongsakul. Augmented lagrangehopfield network for economic load dispatch with combined heat and power. *Electric Power Components and Systems*, 12(37) 0-0, 2010.
- Vo Ngoc Dieu, Weerakorn Ongsakul. Enhanced augmented Lagrange Hopfield network for constrained economic dispatch with prohibited operating zones. *Engineering Intelligent Systems*, 4(17) 0-0, 2010.
- Vo Ngoc Dieu, Weerakorn Ongsakul. Enhanced augmented Lagrange Hopfield network for constrained economic dispatch with prohibited operating zones. *Engineering Intelligent Systems*, 1(17) 0-0, 2010.
- Vo Ngoc Dieu, Weerakorn Ongsakul. Improved merit order and augmented Lagrange Hopfield network for short term hydrothermal scheduling. *Energy Conversion and Management*, 12(50) 0-0, 2010.
- W. Prommee and W. Ongsakul "Optimal multiple distributed generation placement in microgrid system by improved
- Watcharejyothin M., Ram M. Shrestha. Effects of cross-border power trade between Laos and Thailand: Energy security and environmental implications. *Energy Policy*, 5(37) 0-0, 2010.
- Watcharejyothin M., Ram M. Shrestha. Regional energy resource development and energy security under CO2 emission constraint in the greater Mekong sub-region countries (GMS). *Energy Policy*, 11(37) 0-0, 2010.
- Weerakorn Ongsakul, Jirapong P.. Optimal placement of multi-type FACTS devices to enhance total transfer capability using improved evolutionary programming. *International Journal of Energy Technology and Policy*, 2(7) 0-0, 2010.

Conference/Workshop Presentations

Achayuthakan C., Dent C.J., Bialek J.W., Weerakorn Ongsakul. Electricity tracing in systems with and without circulating flows: Physical insights and mathematical proofs. *IEEE Transactions on Power Systems*, 2(25) 0-0, 2010.

Boonyaritdachochai P., Boonchuay C., Weerakorn Ongsakul. Optimal congestion management in electricity market using particle swarm optimization with time varying acceleration coefficients. *AIP Conference Proceedings*, (1239) 0-0, 2010.

Brahmanand Mohanty, "Asian Voices and Policies for ISO26000 and SA8000: Example of the Hospitality industry", *ADBI Roundtable on "Corporate Environmental Management: From Policy to Practice"*, Bangalore, India, 3-6 May 2010, Bangalore, India.

Brahmanand Mohanty, "Conceptual framework and benefits of energy efficiency in buildings", *The Fifth Kitakyushu Initiative Network Meeting*, 10-11 February 2010, Kitakyushu, Japan.

Brahmanand Mohanty, "Developing guidelines to strengthen national institutional capacity for promoting energy efficiency", *Regional Workshop on strengthening institutional capacity to support energy efficiency in Asian countries*, organized by United Nations Economic Social Commission for Asia and the Pacific, 23-25 March 2010, Bangkok, Thailand.

Brahmanand Mohanty, "Energy efficiency: challenges and opportunities for green Asia Pacific business and green bridge with Europe", *Business Forum: Green and competitive*, 6th Ministerial Conference on Environment and Development, 30 September 2010, Astana, Kazakhstan.

Brahmanand Mohanty, "Energy Efficient Lighting: A low-hanging fruit, Round table on LED lighting technology", *EMPOWER INDIA Exhibition and Seminar*, 25-27 June 2010, Chennai Trade Centre, India.

Brahmanand Mohanty, "E-tool for good environmental practices for small hotels and resorts", *Seminar on Sustainability in the Accommodation Sector: Practical tools for integrating Biodiversity Practices in Tourism Businesses*, organized by the Tourism Authority of Thailand, French Development Agency and United Nations Environment Program, 10-11 May 2010, Phuket, Thailand.

Brahmanand Mohanty, "Large scale implementation of energy efficiency in buildings", *The Fifth Kitakyushu Initiative Network Meeting*, 10-11 February 2010, Kitakyushu, Japan.

Brahmanand Mohanty, "Methods and tools to assess and reduce GHG emissions of urban territories: Sharing the French experience", *Indo-French Workshop on Science, Technology and Humanities - a Tryst with Sustainable Development*, 27-29 January 2010, Bangalore, India.

Brahmanand Mohanty, "Sustainable tourism in the present context", *Workshop on "Sustainability in the Accommodation Sector: Practical tools for good environmental Practices in Tourism Businesses*, organized by the Tourism Authority of Thailand and United Nations Environment Program, 8 July 2010, Chiang Mai, Thailand.

Brahmanand Mohanty, "Sustainable urban energy solutions for Asia", *Polycity Final Conference, Citynet Workshop*, 15-17 September 2010, Stuttgart, Germany.

Chamaiporn Teerasetsoyon, S. Kumar and Joydeep Dutta "Ultrasonic Spray Pyrolysis preparation of Dye-Sensitized Solar Cells Photoelectrode" *International*

Workshop on Advanced Materials (IWAM 2010), 20-24 February, 2010, Ras Al Khaimah, United Arab Emirates.

J. G. Singh, S. N. Singh, S. C. Srivastava, and Lennart Söder, "Power System Security Enhancement by Optimal Placement of UPFC", *The Fourth IASTED Asian Conference on Power and Energy Systems, AsiaPES 2010*, 24-26 November, 2010, Phuket, Thailand. Nuttapol Limjeerajarus, Apinya Aksornkij, Sawanya Suwannawong, and S. Kumar, "Sky Temperature Estimation by Three Metallic Plates Method", *International Conference of Business and Industrial Research*, March 17-18, 2010, Bangkok, Thailand.

P. Abdul Salam, S. Kumar and Manjula Siriwardhana, "A Review of Biomass Gasification in the Mekong Region", *International Conference on Innovations for Renewable Energy*, 21-23 September 2010, Hanoi, Vietnam.

S. Kumar and C. Palaniappan, *Recent trends in solar drying technologies*, *International Conference on Post Harvest management and Valorisation of Agri - Horticultural Produce*, 19-20 February 2010, New Delhi, India.

S. Kumar, "A Territorial Climate Plan approach leading to Resource Efficient Cities, 1st Regional Symposium on Integrated Energy and Environmental Management", 15-16 December 2010, Palembang, Indonesia.

S. Kumar, *Energy and Climate Change, Pollutetech 2010 - National level conference cum Exhibition*, 28-29 October 2010, Bangalore, India.

S. Kumar, *Experiences on Asia Renewable Energy Technology*, 2010 *Cities International Conference on Renewable Energy and Sustainable Development*, 8-9 September 2010, Kaohsiung, Taiwan.

S. Kumar, Postgraduate education to nurture human resources in the field of environment in Asia, International Forum on Higher Education, Global Environmental Leaders Development and Human Resource Networking, 2 December 2010, Nagoya, Japan.

Saksinchai A., Boonchuay C., Weerakorn Ongsakul. Multi-objective bidding strategy for GenCo using non-dominated sorting particle swarm optimization. AIP Conference Proceedings, (1239) 0-0, 2010.

Sasidharan Sreedharan, Weerakorn Ongsakul, and J. G. Singh, "Maximization of Instantaneous Penetration using Particle Swarm Optimization," *International Journal of Engineering, Science and Technology*, Vol. 2, No. 5, pp. 39-50, 2010.

Sasidharan Sreedharan, Weerakorn Ongsakul, Jai Govind Singh, Mahapatra S. S., "Development of PSO based Robust Controller for Maximizing Wind Penetration," *International Journal of Renewable Energy Technology*, 2010 (accepted for publication).

Supattana Nirukkanaporn and S. Kumar, "A Transition to bilateral trading ESI – effect to generation dispatched cost" *International Journal of Energy Sector Management*, Vol. 4 No. 4, pp. 577-592, 2010.

Report

Low – Carbon Society Vision 2030 Thailand by Bundit Limmeechockchai, Sirindhorn International Institute of Technology, Asian Institute of Technology, National Institute for Environmental Studies, Kyoto University, Mizuho Information & Research Institute and Asia-Pacific Integrated Model.

5.4.7 Doctoral Students' Dissertation

Analyses of Economic and Environmental Implications for Thailand of Integrated Energy Resource Development in Selected Greater Mekong Subregion Countries.
By Mayurachat Watcharejyothin
Supervisor: Prof. Ram M Shrestha

Daylighting through Unshaded and Shaded Windows
By Lerdlekha Tanachaikhan
Supervisor: Prof. Sivanappan Kumar

Development of the PSO Based Robust Controller for Maximizing Wind Energy Penetration in Power Systems
By Sasidharan Sreedharan
Supervisors: Dr. Weerakorn Ongsakul / Dr. Jai Govind Singh

Electricity Generation Cost Under a Reform of the Electric Supply Industry in Thailand
By Supattana Nirukkanaporn
Supervisor: Prof. Sivanappan Kumar

5.4.8 Masters Students' Theses and Research Studies

A Low Carbon Campus through Energy Efficiency and Energy Conservation Measures
By Autchara Poothngamnil
Supervisor: Prof. Sivanappan Kumar

An Analysis of Electricity Demand and Pollutant Emissions Using Cointegration and ARIMA Modeling: A Case Study of Thailand
By Thad Aosombatkun
Supervisor: Dr. Charles Marpuang

An Analysis of Energy Emissions in Urban Households in Metropolitan Bangkok
By Peach Sriwaranan
Supervisors: Prof. Sivanappan Kumar / Prof. Ram M. Shrestha

An Analysis of Energy Use in the Urban Residential Sector of Nepal
By Prabina Chhetri
Supervisor: Prof. Sivanappan Kumar

Assessment of Clean Development Mechanism Projects for Net CO₂ Mitigation in Thailand
By Wikanda Pensupa
Supervisor: Dr. Charles O.P. Marpuang

Assessment of Energy Conservation Potential in the Indian Foundry Industry
By Abhinad Anil Joshi
Supervisor: Prof. Sivanappan Kumar

Assessment of Renewable Energy Resources Potential and Application for Decentralized Rural Electrification Using Geographic Information System (GIS)
By Earl Macamay Opiso
Supervisor: Prof. Sivanappan Kumar

Distributed Expansion Planning Considering Grid Connection Rood Top PV Systems: The Case of Chiang Mai City, Thailand
By Paradorn Sriprasat
Supervisor: Dr. Weerakorn Ongsakul

Effect of Renewable Portfolio Standard on Energy Security and the Environment: Case of Thailand
By Suddan Saelin
Supervisors: Dr. Charles O.P. Marpuang / Prof. Ram M. Shrestha

Energy Conservation in an Indian Winery
By Aalok Hemant Awalikar
Supervisor: Prof. Sivanappan Kumar

Financial Transmission Right Bidding Strategy in Competitive Power Market Using Particle Swarm Optimization
By Yada Rungreang
Supervisor: Dr. Weerakorn Ongsakul

GreenHouse Gas Emission & its Mitigation Options: A Case for Nepal
By Barsha Pandey
Supervisors: Dr. Charles O.P. Marpuang / Prof. Ram M. Shrestha

Greenhouse Gas Mitigation by Hydro Power Trading from Myanmar to Thailand
By Cherry Myo Lwin
Supervisor: Dr. Weerakorn Ongsakul

Impact of Distributed Generation in Steady State, Voltage and Transient Stability Analysis: A Case of DanSai System, Thailand
By Ratchaporn Vairuangsiripong
Supervisor: Dr. Weerakorn Ongsakul

Impacts of Distributed Generation on the Protective Devices in the PEA Distribution System

By Pauranee Satphaisarnkit
Supervisors: Dr. Weerakorn Ongsakul / Dr. Jai Govind Singh

Integrated Resource Planning Considering Demand Side Management - A Case Study of Vietnam

By Ngo Dang Chien
Supervisor: Dr. Weerakorn Ongsakul

Long-term CO₂ Emission Reductions Target and Scenario for the Industrial Sector of Thailand

By Arisa Sumthong
Supervisor: Dr. Charles O.P. Marpuang

Long Term Peak Load Forecasting Using Artificial Neural Network: A Case of Java Madura-Bali Interconnection, Indonesia.

By Yusak Tanoto
Supervisor: Dr. Weerakorn Ongsakul

Multi-Objective Bidding Strategy for Genco Using Non-Dominated Sorting Particle Swarm Optimization

By Apinat Saksinchai
Supervisor: Dr. Weerakorn Ongsakul

Multi-Objective Distributed Generation Optimal Placement in Distribution System using Nondominated Sorting Particle Swarm Optimization

By Bancha Rangsakorn
Supervisor: Dr. Weerakorn Ongsakul

Opportunities of Low Carbon Technologies and Green House Gases Mitigation Potential in the Thai Cement, and Pulp and Paper Industries

By Pichet Ninduangdee
Supervisors: Dr. P. Abdul Salam / Prof. Sivanappan Kumar

Optimal Bidding Strategy in LMP - Based Electricity Market Considering Elastic Demand by Particle Swarm Optimization

with Time-Varying Acceleration Coefficients

By Nuttawich Khamsawasd
Supervisor: Dr. Weerakorn Ongsakul

Optimal DG Allocation in the Nodal Price Base Electricity Market: The Case of Cambodia Power System

By Mom Kirivathanak
Supervisor: Dr. Weerakorn Ongsakul

Optimal Generation Scheduling of Cascaded Hydro-Thermal and Wind Power Generation by Particle Swarm Optimization

By Seema Thakur
Supervisor: Dr. Weerakorn Ongsakul

Optimal Under-Voltage Load Shedding for Thailand Power System

By Agapol Pukprayura
Supervisor: Dr. Weerakorn Ongsakul

Portfolio Risk Analysis Based on Generation Expansion Planning

By Nguyen Xuan Phuc
Supervisors: Dr. Charles O.P. Marpuang / Prof. Ram M. Shrestha

Reliability Improvement by Microgrid System: The Case of Mae Hong Son, Thailand

By Sitthigorn Promthaworn
Supervisor: Dr. Weerakorn Ongsakul

Saddle Node Bifurcation and Voltage Stability Studies in Electric Power Systems

By Dinesh Rangana Gurusinghe
Supervisor: Dr. Weerakorn Ongsakul

Strategies Towards a Low Carbon Society: A Case Study on Transport and Industrial Sector of Kathmandu Valley, Nepal

By Saurabh Thaiba
Supervisor: Dr. Charles O.P Marpuang

Total Transfer Capability Enhancement Using FACTS Devices: A Case Study of Bhutan Power System

By Purna Bdr Rai
Supervisor: Dr. Weerakorn Ongsakul

Towards a Low Carbon City: Analysis of Sustainable Transport Options for Bangkok, Thailand

By Chawannat Jaroenkhasemmesuk
Supervisors: Dr. Charles O.P. Marpuang / Prof. Ram M. Shrestha

Wind Power Bidding Strategy in Short-Term Power Markets Based on Particle Swarm Optimization

By Nitipong Thipwiang
Supervisor: Dr. Weerakorn Ongsakul

Research Study: Energy/Electricity Consumption and Economic Growth in Pakistan: A Cas-Sulity Analysis

By Arshad Mahmood
Supervisor: Dr. Charles O.P. Marpuang

Research Study: The Transition to a Hydrogen Economy in Thailand

By Natthakich Assanee
Supervisor: Dr. Charles O.P. Marpuang

Research Study: Analysis of a Micro Combine Heat Power as a Clan Development Mechanism Project in Residential Area, Hanoi, Vietnam.

By Tran Thi Kieu Ngoc
Supervisor: Dr. Charles O.P. Marpuang

5.5: SERD – ENVIRONMENTAL ENGINEERING AND MANAGEMENT FIELD OF STUDY

5.5.1 Introduction

Environmental Engineering at AIT began in 1964 with the need for sanitary engineering to address the problems of providing adequate water supplies and sanitation facilities. This pioneering environmental engineering program has grown into a range of fields needed to tackle the environmental issues facing Asia today.

Environmental Engineering and Management Field of Study is part of the School of Environment, Resources and Development. The overall program looks for solutions to environmental problems, water supply and sanitation, wastewater treatment and disposal systems, air pollution, solid and hazardous wastes, waste minimization, and life cycle assessment, environmental impact assessment and management and environmental toxicology. The three major focal areas are Environmental Technology and Management, Environmental Toxicology, Technology and Management, and Water and Wastewater Engineering

5.5.2 Research Facilities and Laboratories

The Environmental Engineering (EE) Laboratory is housed with facilities to handle a wide range of knowledge and skills in problem solving for industrial needs and analytical works for physical, chemical, microbiological, and environmental parameters such as water and wastewater quality, air pollutants and noise level, and solid waste. For teaching, training and research purposes, the EE laboratory is categorized into three sub-laboratories namely, research, ambient, and environmental research station. The research laboratory is equipped with many sophisticated instruments such as GC-IRD-MSD, HPLC,

UV-Vis spectrophotometers, atomic absorption analyzer with flame, graphite and cold vapor operations, and gas and liquid chromatographs. For lab and pilot scale testing purposes, the ambient laboratory has furnished with facility to conduct experiments for treating sludge, sewage, air toxics and industrial wastes. It is also housed with advanced water and wastewater treatment units such different membrane bioreactors, and high rate anaerobic treatment processes with methane gas recovery. The Environmental Research Station consists of pilot scale aerobic and anaerobic biological wastewater treatment units, constructed wetlands, waste stabilization ponds, a lysimeters for solid waste treatment, a hazardous wastewater treatment plant and ambient air monitoring station.

Among its major equipment include Gas Chromatograph; High Performance Liquid Chromatograph; Atomic Absorption Spectrometer; Total Organic Carbon Analyzer; Ion Chromatograph, Induced Couple Plasma, UV Spectrophotometer; Supercritical Fluid Extractor; Microwave Digestion System ; Primus Thermal Cyclers ; Universal Mutation Detection System; Microscope; Microbalance; Microcentrifuge.

5.5.3 Faculty and Research Staff

Full-time Faculty

AJIT P ANNACHHATRE, BTech, PhD,
Indian Inst of Tech, Kanpur, India.

Professor (*Anaerobic Wastewater Treatment; Biofilm Processes; Environmental Biotechnology; Environmental Impact Assessment; Mathematical Modeling*)

CHETTIYAPPAN VISVANATHAN,
BTech, IIT, Madras, India; MEng, AIT,
Thailand; PhD, Inst Natl Polytech,
Toulouse, France.

Professor (*Cleaner Production; Industrial Environment Management; Membrane Technology for Water and Wastewater Treatment and, Solid Waste Management*)

SAID IRANDOUST, MSc, PhD,
Chalmers University of Technology,
Sweden.

Professor (*Chemical Reaction Engineering*)

NGUYEN THI KIM OANH, Dip Eng,
Odessa Hydrometeorology Inst,
Ukraine; MEng, DEng, AIT, Thailand.

Professor (*Air Pollution Engineering and Management, Transboundary air pollution, Air Pollution and Climate Interaction/Co-benefit, Environmental Monitoring and Modelling, Exposure Assessment, Integrated Industrial Environment Management*)

OLEG V SHIPIN, PhD, Inst of
Biochemistry and Physiology of
Microorganisms, Moscow, Russia.

Associate Professor (*Ecological Engineering for climate change adaptation; Environmental Impact Assessment; Microbial biotechnology and nanotechnology; Natural systems (ponds and wetlands) as Wastewater treatment systems; Microbial aspects of Environmental Engineering; Health and Ecological Risk assessment*)

PREEDA PARKPIAN, BSc, Kasetsart Univ, Thailand; MSc, Mississippi State Univ; PhD, Texas A&M Univ, USA.

Associate Professor
(*Ecotoxicology; POPs; Heavy Metals; Micronutrient Chemistry; Remediation of Polluted Soil and Water*)

THAMMARAT KOOTATEP, BEng, Chiangmai Univ; MEng, DEng, AIT, Thailand.

Assistant Professor
(*Decentralized Waste and Wastewater Treatment Systems; Sustainable Sanitation; Eco-engineering Technology for Waste and Wastewater Treatment and Management; Environmental Health and Sanitation*)

Visiting and Adjunct Faculty

CHONGRAK POLPRASERT, BEng, Chulalongkorn Univ, Thailand; MEng, AIT, Thailand; PhD, Univ of Washington, USA.

Adjunct Faculty (*Hazardous Waste Engineering; Resources Recovery; Sanitation*)

HATHAIRATANA GARIVAIT, BS (Science de la structure et de la matiere), Ms (Chimie Physique), University of Paris 7, France; DTechSc, AIT, Thailand.

Adjunct Faculty (*Statistics and Environmental Management Systems*)

JENS PETER THOMSEN, Cand. scient, University of Copenhagen and Aarhus, Denmark.

Adjunct Faculty (*Ecotoxicology as a Tool in Environmental Management*)

KARE HELGE KARSTENSEN, BS, MS, University of Oslo; MBA, Heriott Watt University, UK; MLaw, University of Oslo; Dr.Sc, Norwegian University of Science and Technology, Trondheim, Norway.

Visiting Faculty (*Sustainable Management of Industrial and*

Hazardous Wastes; Management of Hazardous Chemicals, POPs and Obsolete Pesticides; Sustainable Production of Cement and Co-Processing of Alternative Fuel and Raw Materials and Hazardous Wastes; Control and Minimization of unintentionally produced POPs (dioxins, furans, PCBs and HCB) and application of Best Available Technologies & Best Environmental Practices (BAT/BEP))

KIMBERLY NEIL IRVINE, BSc, Toronto Univ, Canada; MSc, PhD, McMaster Univ, Canada.

Adjunct Professor (*Hydrology and Water Resource Management, with specific emphasis on evaluating water quality in urban-impacted water bodies*)

SHINICHI OKAMOTO, BEng, MEng, DEng, Waseda Univ, Japan.

Visiting Professor (*Statistics and Environmental Management Systems*)

Affiliated Faculty

KHUNYING MATHUROS RUCHIRAWAT, PhD, Massachusetts Institute of Technology, USA.

Affiliated Faculty (*Nutrition Biochemistry and Metabolism*)

SKORN MONGKOLSUK, PhD, University of Maryland, USA.

Affiliated Professor (*Biological Science*)

JUTAMAAD SATAYAVIVAD, PhD, Mahidol University, Thailand.

Affiliated Faculty (*Pharmacology*)

Research Staff

AJAYA SAPKOTA, BSc

Research Assistant (*Conducts lab experiments and assist students in their lab activities; assist project leader with research project, training*

activity)

ALBERTO E. PEDRAJAS, MEng
Research Associate (*Manages research projects, prepares technical reports and presentations*)

ALFREDO ANCENO, PhD
Research Scientist (*Conducts lab experiments and assist students in their lab activities; assist project leader with research project, training activity, writes project proposals*)

AMILA ABEYNAYAKA, MEng
Research Associate (*Manages research projects, prepares technical reports and presentations*)

ANAND DESHMUKH, MSc
Research Associate (*Manages research projects, prepares technical reports and presentations*)

ANCY R. JOHNSON, MSc
Research Associate (*Manages research projects, prepares technical reports and presentations*)

ANTOINE MOREL, MEng
Senior Research Associate (*Assists in project coordination, prepares project reports, prepares project budgets and manages project finances, support project leader in supervision of AIT and NCCR master and doctoral students and trainees in the field of environmental sanitation*)

AROSHA S. KUMARAGE, BA
Research Assistant (*Financial management and assist the team in regular research project and training activities*) *Manages research projects, prepares technical reports and presentations*)

ASIF IQBAL, MEng

Research Associate (Manages research projects, prepares technical reports and presentations)

ATITAYA PANUVATVANICH, DEng

Senior Research Associate, (Manages research projects; assists in project coordination, prepares project reports, prepares project budgets and manages project finances; assist team leader in training activities)

AUNG ZAW NAING LIN, MSc

Research Associate (Actively involve in Asian Regional Research Programme on Environmental Technology Program (ARRPET) research activities)

CHAIYAPORN IMSAPSANGWORN, BSc

Senior Technician (Assess laboratory routine testing and analysis, maintain the operation of the laboratories, instruments and equipment, chemical and lab preparation for EEM laboratories sessions, data collection and fieldwork assistance to students and research staff)

CHUTHATHIP SIRIPONG, MEng

Research Associate (Manages research projects, prepares technical reports and presentations)

DO THI THANH CANH, MSc

Research Associate (Manages research projects, prepares technical reports and presentations)

JACQUELINE KNEE, MSc.

Research Fellow (Manages research projects, prepares technical reports and presentations)

JAVKHLAN ARIUNBAATAR, MSc

Research Associate (Manages research projects, prepares technical reports and presentations)

JEERAPUN TANUNCHAI, BSc

Research Assistant (Laboratory operating and sample analysis, prepares technical reports and presentations, collaborating with research partners)

JIDAPA KHATIKARN, MEng

Research Associate (Manages research projects, prepares technical reports and presentations)

KAUSHALYA C. WIJEKOON, MEng

Research Associate (Manages research projects, prepares technical reports and presentations)

KETSIRI LEELASAKULTUM, MSc

Research Associate (Manages research projects on diesel particulate matter and air pollutants analysis; prepares technical reports and presentations)

MADDALA PADMASRI, MEng

Research Associate (Manages research projects, prepares technical reports and presentations)

MAI THI THUY PHUONG, MSc

Research Associate (Manages research projects on diesel particulate matter and air pollutants analysis; prepares technical reports and presentations)

MANOJ YOMJINDA, MSc

Research Laboratory Supervisor (Supervises instrumentation and data acquisition, calibration and maintenance of analytical instruments, assistant to senior laboratory supervisor for such as teaching, lab management)

NANG HTAY YIN, MSc

Research Associate (Manages research projects, prepares technical reports and presentations)

NARISSARA KAEWPHAN, BSc

Research Assistant (Conducts lab experiments and assists students in their lab activities; assist project leader with research project, training activity)

NARONG SURINKUL, DEng

Senior Research Engineer, (Manages research projects; assists in project coordination, prepares project reports, prepares project budgets and manages project finances; assist team leader in training activities)

NAVARATNAM C. USHANTHI, BEng

Research Assistant (Conducts lab experiments and assists students in their lab activities; assist project leader with research project, training activity)

NEERAYA RATTANASTACHAN, MEng

Research Associate (Manages research projects, prepares technical reports and presentations)

NGUYEN THANH HANG, MSc

Research Associate (Manages research projects, prepares technical reports and presentations)

ORATHAI KLUBBARNKOH, BSc

Senior Technician (Chemistry and environmental analysis for environmental samples as well as prepare for chemical and glassware for laboratory courses and research projects)

PANNAWEE MEKWICHAI, MSc

Research Associate (Manages research projects, prepares technical reports and presentations)

- PANNITA SUTTISAWAD, BEng
Research Assistant (*Laboratory operating and sample analysis, prepares technical reports and presentations, collaborating with research partners*)
- PANUPONG BOONYANUN, BTech (Mech.)
Senior Technician (*Responsible for the repair and maintenance of related machines, assists students in laboratory experimental work and experimental set-up, carry out routine maintenance and repair of laboratory equipment and facilities*)
- PATTARAWAN
CHULARUENGOAKSORN, MSc
Research Associate (*Manages research projects, prepares technical reports and presentations*)
- PIMLUCK KIJJANAPANICH, MSc
Research Associate (*Manages research projects, prepares technical reports and presentations*)
- PRAPAT PONGKIATKUL, DEng
Senior Research Engineer, (*Manages research projects on air pollution; assists in project coordination, prepares project reports, prepares project budgets and manages project finances; assist team leader in training activities*)
- PREM ANANTH ANIYARANGAN, MEng
Senior Research Associate (*Manages research projects, prepares technical reports and presentations*)
- PREMSAK PUANGPLOY, MSc
Research Associate (*Manages research projects, prepares technical reports and presentations*)
- PUTTIMON KAIWAN-ARPORN, MSc
Research Associate (*Manages research projects, prepares technical reports and presentations*)
- RAQUEL P. PEDRAJAS, MEng
Senior Research Associate (*Assists in project coordination, prepares project reports, budgets and manages project finances, assists in maintenance of project websites, organizes international workshops, conference, training programs and seminars, prepares project brochures, posters, etc., assists in formulation of research proposal, co-edits project newsletters, assists evaluation of reports from National Research Institutions involved in the project*)
- RATTAPON ONCHANG, Dr.-techn.
Visiting Researcher (*Manages RTG research project, prepares technical reports and serves as committee member for master thesis*)
- SALAYA PHUNSIRI, MSc
Senior Laboratory Supervisor (*Administrative for Environmental Engineering Laboratory as well as supervise for experimental and research projects on water, wastewater, air pollution, and solid wastes analysis*)
- SAMBIT ROURAY, MSc
Research Associate (*Manages research projects, prepares technical reports and presentations*)
- SANJEET AMATYA, MEng
IT Officer (*Manages research projects, prepares technical reports and presentations*)
- SIN KHANNDARITH, MEng
Research Associate (*Manages research projects, prepares technical reports and presentations*)
- SOMCHAI AREMSUM-ANG, BSc
Research Assistant (*Wastewater and soil analysis, field survey and data collection, testing and other laboratory sessions*)
- SRUNG SMANMOO, PhD
Visiting Researcher (*Manages RTG research project, prepares technical reports and serves as committee member for master thesis*)
- SUPARATTANA SURIYAKHAM, BEng
Research Assistant (*Laboratory operating and sample analysis, prepares technical reports and presentations, collaborating with research partners*)
- SUTHIRAT KITTIPONGVISES, MSc
Research Associate (*Manages research projects on hazardous chemical management; assist the project leader in training activities; prepares technical reports and presentations*)
- SYARIFAH HIKMAH JULINDA SARI, MSc
Research Associate (*Manages research projects, prepares technical reports and presentations*)
- TANTIMA SUWANNAPAN, BSc
Research Assistant (*Conducts lab experiments and assists students in their lab activities; assist project leader with research project, training activity*)
- THANUN POONSAWAT, MEng
Research Associate (*Manages research projects, prepares technical reports and presentations*)
- THEERADEJ BOONMA-NGUM, BSc
Research Assistant (*Conducts lab experiments and assists students in their lab activities; assist project leader with research project, training activity*)

VENKATAPPA MANJUNATHA, MSc
Research Associate (*Manages research projects, prepares technical reports and presentations*)

WALAIPORN SIRIRATWATTHANA, MSc
Research Associate (*Manages research projects, prepares technical reports and presentations*)

WIJITTRA SANSUD, BSc
Senior Technician (*Manages laboratory chemical and equipment inventory; issue chemical and equipments for students; conduct water analysis; assist in organizing laboratory sessions*)

5.5.4 Grants and Sponsored Research Completed in 2010

Air quality and climate impacts of Switching to Natural Gas fueled Public Transportation Vehicles in Bangkok
 Duration: 01 Aug 09 - 30 Nov 10
 Project Investigator(s): Nguyen Thi Kim Oanh
 Sponsor: RTG
 Total Contracted Amount (THB): 850,000

Determining Factors of Groundwater use and its Quality in Nakomprathom and Samutsakorn Provinces
 Duration: 06 Feb 09 - 31 Dec 10
 Project Investigator(s): Thammarat Koottatep
 Sponsor: Thai Water Supply Public Company Lts
 Total Contracted Amount (THB): 1,952,200

Healthcare Waste Management Facility Design and Operation Guidelines for Laos
 Duration: 01 Sep 09 - 30 Jun 10
 Project Investigator(s): C Visvanathan
 Sponsor: ADB, Philippines
 Total Contracted Amount (THB): 1,650,000

Low-Cost Treatment of Septage by Constructed Wetlands and Pond Systems in Tropical Regions
 Duration: 01 Aug 96 - 31 Dec 10
 Project Investigator(s): Thammarat Koottatep
 Sponsor: Swiss Federal Institute for Environmental Science and Technology (SANDEC)
 Total Contracted Amount (THB): 6,993,981

Phyto-Bioremediation for VOCs at Contaminated Site
 Duration: 01 Nov 07 - 31 Oct 10
 Project Investigator(s): Chongrak Polprasert, Preeda Parkpian
 Sponsor: NEDO/ Shimizu Corporation Japan
 Total Contracted Amount (THB): 1,080,000

Pilot scale field testing of ceramic microfiltration system for high turbid surface water treatment (Phase II)
 Duration: 01 May 09 - 31 Dec 10
 Project Investigator(s): C. Visvanathan
 Sponsor: University of Tokyo, Japan
 Total Contracted Amount (THB): 1,020,000

Pilot scale study on surface water treatment using hybrid ceramic membrane filtration system (phase III)
 Duration: 02 Apr 10 - 31 Dec 10
 Project Investigator(s): C Visvanathan
 Sponsor: University of Tokyo Japan
 Total Contracted Amount (THB): 698,000

Real Time PCR Diagnostic Kit for Giardia and Cryptosporidium parasites
 Duration: 01 Aug 08 - 30 Nov 10
 Project Investigator(s): Oleg Shipin
 Sponsor: NIH USA
 Total Contracted Amount (THB): 2,354,700

Stakeholder Engagement: Pilot Project Stakeholder dialogues and its application for Social Corporate Responsibility
 Duration: 25 Jul 09 - 31 Dec 10
 Project Investigator(s): Thammarat Koottatep
 Sponsor: SCG Paper Public Co Ltd
 Total Contracted Amount (THB): 780,300

The development of a Supersensitive Chemo sensor kit for the detection of Hg(II) in aqueous environment and in living cells
 Duration: 01 Sep 09 - 30 Nov 10
 Project Investigator(s): Preeda Parkpian
 Sponsor: RTG
 Total Contracted Amount (THB): 928,000

US-ASEAN Next Generation Cook Stove Workshop
 Duration: 01 Sep 09 - 31 Mar 10
 Project Investigator(s): Nguyen Thi Kim Oanh
 Sponsor: Air Force Office of Scientific Research (AFOSR)
 Total Contracted Amount (THB): 330,000

Workshop for Policy Makers on Decentralized Wastewater Treatment and Management
 Duration: 15 Feb 10 - 31 Aug 10
 Project Investigator(s): Thammarat Koottatep, Preeda Parkpian

Sponsor: JICA Thailand Office
 Total Contracted Amount (THB): 321,250

5.5.5 On-going Grants and Sponsored Research

Asian Regional Research Programme on Environmental Technology (ARRPET): Phase II – AIT Air Pollution
 Duration: 01 Jan 04 - 30 Jun 11
 Project Investigator(s): Nguyen Thi Kim Oanh, Chongrak Polprasert
 Sponsor: Swedish International Development Cooperation Agency, Sweden
 Total Contracted Amount (THB): 11,448,249

Asian Regional Research Programme on Environmental Technology (ARRPET): Phase II- AIT IHWTM
 Duration: 01 Jan 04 - 30 Jun 11
 Project Investigator(s): Ajit P. Annachhatre
 Sponsor: Swedish International Development Cooperation Agency, Sweden
 Total Contracted Amount (THB): 9,641,212

Asian Regional Research Programme on Environmental Technology (ARRPET): Phase II – AIT Solid Waste
 Duration: 01 Jan 04 - 30 Jun 11
 Project Investigator(s): C. Visvanathan
 Sponsor: Swedish International Development Cooperation Agency, Sweden
 Total Contracted Amount (THB): 8,536,634

Asian Regional Research Programme on Environmental Technology (ARRPET): Phase II – AIT WWTM
 Duration: 01 Jan 04 - 30 Jun 11
 Project Investigator(s): Ajit P. Annachhatre
 Sponsor: Swedish International Development Cooperation Agency, Sweden
 Total Contracted Amount (THB): 8,889,120

Asian Regional Research Programme on Environmental Technology (ARRPET): Phase II - Coordination
 Duration: 01 Jan 04 - 30 Jun 11
 Project Investigator(s): Ajit P. Annachhatre
 Sponsor: Swedish International Development Cooperation Agency, Sweden
 Total Contracted Amount (THB): 10,457,881

Asian Regional Research Programme on Environmental Technology (ARRPET): Phase II-NRI- Air Pollution
 Duration: 01 Jan 04 - 30 Jun 11
 Project Investigator(s): Nguyen Thi Kim Oanh, Chongrak Polprasert
 Sponsor: Swedish International Development Cooperation Agency, Sweden
 Total Contracted Amount (THB): 29,205,301

Asian Regional Research Programme on Environmental Technology (ARRPET): Phase II-NRI-IHWTM

Duration: 01 Jan 04 - 30 Jun 11
 Project Investigator(s): Ajit P. Annachhatre
 Sponsor: Swedish International Development Cooperation Agency, Sweden
 Total Contracted Amount (THB): 30,480,096

Asian Regional Research Programme on Environmental Technology (ARRPET): Phase II – NRI Solid Waste

Duration: 01 Jan 04 - 30 Jun 11
 Project Investigator(s): C. Visvanathan
 Sponsor: Swedish International Development Cooperation Agency, Sweden
 Total Contracted Amount (THB): 21,185,306

Asian Regional Research Programme on Environmental Technology (ARRPET): Phase II- NRI WWTM

Duration: 01 Jan 04 - 30 Jun 11
 Project Investigator(s): Ajit P. Annachhatre
 Sponsor: Swedish International Development Cooperation Agency, Sweden
 Total Contracted Amount (THB): 25,465,225

Asian Regional Research Programme on Environmental Technology (ARRPET): Phase II- Swedish Resource Persons

Duration: 01 Jan 04 - 30 Jun 11
 Project Investigator(s): Ajit P. Annachhatre
 Sponsor: Swedish International Development Cooperation Agency, Sweden
 Total Contracted Amount (THB): 3,516,123

Asian Regional Research Programme on Environmental Technology (ARRPET): Phase II - Workshops

Duration: 01 Jan 04 - 30 Jun 11
 Project Investigator(s): Ajit P. Annachhatre
 Sponsor: Swedish International Development Cooperation Agency, Sweden
 Total Contracted Amount (THB): 9,114,639

Assessment of co benefits on Air Quality and climate resulted from various control strategies in Southeast Asia

Duration: 01 Aug 10 - 01 Aug 12
 Project Investigator(s): Nguyen Thi Kim Oanh
 Sponsor: French Ministry of Foreign Affairs
 Total Contracted Amount (THB): 1,704,000

Capacity Strengthening on Hazardous Chemicals Management

Duration: 01 Jan 07 - 31 Mar 11
 Project Investigator(s): Nguyen Thi Kim Oanh, Chongrak Polprasert
 Sponsor: The Norwegian Ministry of Foreign Affairs
 Total Contracted Amount (THB): 23,732,687

Comparison Study on Air Pollution Characteristics between Seoul and Bangkok

Duration: 01 Mar 10 - 31 Oct 11
 Project Investigator(s): Nguyen Thi Kim Oanh
 Sponsor: Korea Institute of Science and Technology (KIST)
 Total Contracted Amount (THB): 860,832

Database of 3R Good Practices related to Organic Waste

Duration: 20 Jan 10 - 30 Apr 11
 Project Investigator(s): C Visvanathan
 Sponsor: Mitsubishi Research Institute
 Total Contracted Amount (THB): 978,544

Environmental Sanitation and Urban Agriculture

Duration: 25 Sep 02 - 30 Jun 13
 Project Investigator(s): Thammarat Koottatep
 Sponsor: Department of Water and Environmental Sanitation in Developing Countries (SANDEC), Switzerland
 Total Contracted Amount (THB): 21,329,791

Innovative Sanitation approach by Coupling of Ecological reuse system with Health risks determination

Duration: 01 May 10 - 30 Apr 11
 Project Investigator(s): Thammarat Koottatep
 Sponsor: NCCR North-South Center for Development and Environment
 Total Contracted Amount (THB): 1,400,000

Integrated Sustainable Solid waste Management in Asia

Duration: 01 Jan 09 - 30 Jun 11
 Project Investigator(s): C. Visvanathan
 Sponsor: European Commission
 Total Contracted Amount (THB): 2,449,490

Permeable Reactive Barrier for Remediation of Acid Mine Drainage

Duration: 01 Nov 09 - 30 Oct 11
 Project Investigator(s): Ajit P. Annachhatre
 Sponsor: UNESCO -IHE
 Total Contracted Amount (THB): 972,270

Policy Study on Technology Transfer for 3R

Duration: 01 Jul 10 - 30 Jun 11
 Project Investigator(s): C Visvanathan
 Sponsor: Institute for Global Environmental Strategies, Japan
 Total Contracted Amount (THB): 640,000

Professional Master in Environmental Engineering and Management, Hanoi 2010

Duration: 01 May 10 - 31 Aug 11
 Project Investigator(s): Nguyen Thi Kim Oanh
 Sponsor: Environmental government and private companies, Vietnam
 Total Contracted Amount (THB): 2,892,000

Research Mission Trips of AIT Faculty

Duration: 01 Sep 10 - 31 Aug 12
 Project Investigator(s): Ajit P. Annachhatre
 Sponsor: SDCC AIT France Network
 Total Contracted Amount (THB): 288,000

Strategic Environmental Assessment for North and Central Afghanistan to ensure sustainable use of water resources

Duration: 01 Aug 10 - 31 Aug 12
 Project Investigator(s): Oleg Shipin
 Sponsor: British Council UK
 Total Contracted Amount (THB): 2,328,000

Sustainability issues due to Coal Ash from Coal fired Power plants

Duration: 01 Sep 10 - 31 Aug 12
 Project Investigator(s): Ajit P. Annachhatre
 Sponsor: SDCC AIT France Network
 Total Contracted Amount (THB): 1,800,000

Sustainable Water Management in Urban Fringe Areas through Industrial Wastewater Reuse

Duration: 01 Mar 10 - 31 Jan 12
 Project Investigator(s): C Visvanathan
 Sponsor: French Ministry of Foreign Affairs
 Total Contracted Amount (THB): 1,343,441

Technical Assistance for the setup of a Credit Facility to support Ecosystems friendly Accommodations in Coastal areas of Thailand

Duration: 25 Mar 10 - 31 Jan 14
 Project Investigator(s): Thammarat Koottatep
 Sponsor: French Development Agency AFD
 Total Contracted Amount (THB): 1,950,000

5.5.6 Publications

International Journal Articles with Impact factor

Abeynayaka A. and C. Visvanathan. Mesophilic and thermophilic aerobic batch biodegradation, utilization of carbon and nitrogen sources in high-strength wastewater. *Bioresource Technology*, 102, 2358-2366, 2011.

Abeynayaka A. and C. Visvanathan. Performance comparison of mesophilic and thermophilic aerobic side-stream membrane bioreactors treating high strength wastewater. Acceptable for publication in *J. of Bioresource Technology*, 2010.

- Anbumozhi V., Gunjima T., A. Prem Ananth and C. Visvanathan. Assessment of Inter-firm Networks in a Wood Biomass Industrial Cluster: Lessons for Integrated Policymaking Clean Technologies and Environmental Policy. *Clean Technologies and Environmental Policy*. 12, 365-372, 2010.
- Anceno A.J., Rouseau P., Beline F., Oleg Shipin and Dabert P. Evolution of N-converting bacteria during the start-up of anaerobic digestion coupled biological nitrogen removal pilot-scale bioreactors treating high-strength animal waste slurry. *Bioresource Technology*, 14(100) 0-0, 2010.
- Ariunbaatar J. and Chongrak Polprasert. Assessment of sustainability indicators for solid waste management in Ulaanbaatar, Mongolia. *Waste management (New York, N.Y.)*, 3(30) 0-0, 2010.
- Brix H., Thammarat Koottatep, Fryd O. and Laugesen C.H. The flower and the butterfly constructed wetland system at Koh Phi Phi-System design and lessons learned during implementation and operation. *Ecological Engineering*, () 0-0, 2010.
- C. Visvanathan and Prem Ananth A. Industrial Symbiosis through Eco-industrial clustering: A synthesis of a multi-country study in agricultural sector. *Energy Manager*, 03, 04, 19-26, October, 2010.
- C. Visvanathan, Karthikeyan O.P. and Park H.K. Sustainable landfilling in tropical conditions: Comparison between open and closed cell approach. *Waste Management & Research*. Accepted for publication in September, 2010.
- C. Visvanathan, Yin N.H., and Karthikeyan O.P. Co-disposal of electronic waste with municipal solid waste in bioreactor landfills. *Waste Management*, 30 2609-14, 2010.
- C. Visvanathan. A Glance at the World: Composting of municipal solid waste: Indian experience. *Waste Management*, 30, 163-164, 2010.
- Channarong B., Bade R. and Oleg Shipin. Simultaneous removal of nickel and zinc from aqueous solution by micellar-enhanced ultrafiltration and activated carbon fiber hybrid process. *Desalination*, () 0-0, 2010.
- Chiemchaisri C., Charnnok B. and C. Visvanathan (2009). Recovery of plastic wastes from dumpsite as refuse-derived fuel and its utilization in small gasification system. *Bioresource Technology*, 101, 1522-27, 2010.
- Diallo M.B.C., Anceno A.J., Tawatsupa B., Nitin K. Tripathi and Oleg Shipin. GIS-based analysis of the fate of waste-related pathogens *Cryptosporidium parvum*, *Giardia lamblia* and *Escherichia coli* in a tropical canal network. *Journal of Water and Health*, 1(7) 0-0, 2010.
- Emberson L.D., Jamir C., Kobayashi K., Nguyen Thi Kim Oanh and Quadri Q.F. A comparison of North American and Asian exposure-response data for ozone effects on crop yields. *Atmospheric Environment*, 12(43) 0-0, 2010.
- Jaikanlaya C., Settachan D., Denison M.S., Mathuros Ruchirawat and Martin van den Berg. PCBs contamination in seafood species at the Eastern Coast of Thailand. *Chemosphere*, 2(76) 0-0, 2010.
- Jiamjitranich W., Chongrak Polprasert, Preeda Parkpian, Delaune R.D. and Jugsujinda A. Environmental factors influencing remediation of TNT-contaminated water and soil with nanoscale zero-valent iron particles. *Journal of Environmental Science and Health - Part A Toxic/Hazardous Substances and Environmental Engineering*, Vol. 45, pp. 263-274.
- Kanabkaew T. and Nguyen Thi Kim Oanh (2010). Development of spatial and temporal emission inventory for crop residue field burning. *Environmental Modeling and Assessment*. DOI: 10.1007/s10666-010-9244-0.
- Khan S.J., Ilyas S., Javid S., C. Visvanathan and Jegatheesan V. Performance of Suspended and Attached Growth MBR Systems in Treating High Strength Synthetic Wastewater. Accepted in *Bioresource Technology*, 2010, Doi: 10:1016/j.biotech.2010.09.100.
- Klinmalee A., Srimongkol K. and Nguyen Thi Kim Oanh. Indoor air pollution levels in public buildings in Thailand and exposure assessment. *Environmental Monitoring and Assessment*, 1-4(156) 0-0, 2010.
- Kondo Y., Nguyen Thi Kim Oanh, Hu M., Kim Y.J. and Kita K. Stabilization of the mass absorption cross section of black carbon for filter-based absorption photometry by the use of a heated inlet. *Aerosol Science and Technology*, 8(43) 0-0, 2010.
- Konnerup D., Thammarat Koottatep and Brix H. Treatment of domestic wastewater in tropical, subsurface flow constructed wetlands planted with *Canna* and *Heliconia*. *Ecological Engineering*, 2(35) 0-0, 2010.
- Le H.A. and Nguyen Thi Kim Oanh (2010). Integrated Monitoring and Modeling for Air Quality Management of Brick Manufacturing Village. *Journal of Environmental Monitoring and Assessment*, 171: 381-394. DOI 10.1007/s10661-009-1285-y
- Liamleam W., Oo Z.K., Thai P.T. and Ajit Annachatre. Pilot scale investigation of zinc and sulphate removal from industrial discharges by biological sulphate reduction with molasses as electron donor. *Environmental Technology*, 12(30) 0-0, 2010.

- Lohwacharin J. and Ajit Annachhatre. Biological sulfide oxidation in an airlift bioreactor. *Bioresource Technology*, 7(101) 0-0, 2010.
- Nawapan S., Charoenlap N., Charoenwuttitarn A., Saenkham P., Skorn Mongkolsuk and Paiboon Vattanaviboon. Functional and expression analyses of the cop operon, required for copper resistance in *Agrobacterium tumefaciens*. *Journal of Bacteriology*, 16(191) 0-0, 2010.
- Nawaz R., Preeda Parkpian, Garivait H., Anurakpongsatorn P. and DeLaune R.D. Impacts of Acid Rain on Base Cations, Aluminum and Acidity Development in Highly Weathered Soils of Thailand. *J. of Communications in Soil Science and Plant Analysis* (submitted).
- Nguyen Thi Kim Oanh, Bich T.L., Tipayarom D., Manadhar B.R, Pongkiatkul P., Simpson C.D. and Liu L-J.S. (2010). Source Characterization of Aerosol Emission from Field Burning of Rice Straw. *Atmospheric Environment*. <http://dx.doi.org/10.1016/j.atmosenv.2010.09.023>.
- Nguyen Thi Kim Oanh, Thiansathit W., Bond T.C., Subramanian R., Winijkul E. and Paw-armart I. (2010). Compositional characterization of PM_{2.5} emitted from in-use diesel vehicles in Asia. *Atmospheric Environment*. 44 (2010) 15–22. doi:10.1016/j.atmosenv.2009.10.00.
- Nguyen Viet H., Cisse G., Thammarat Koottatep, Bonfoh B. and Tanner M. Improving environmental sanitation, health, and well-being: A conceptual framework for integral interventions. *EcoHealth*, 2(6) 0-0, 2010.
- Nithikul J., Karthikeyan O.P. and C. Visvanathan. Reject management from a mechanical biological treatment plant in Bangkok, Thailand. Accepted for publication, *J. Resources, Conservation and Recycling*, 2010.
- Nobuntou W., Preeda Parkpian, Nguyen Thi Kim Oanh, Athapol Noomhorm and Delaune R.D. Lead distribution and its potential risk to the environment: Lesson learned from environmental monitoring of abandon mine. *Journal of Environmental Science and Health - Part A Toxic/Hazardous Substances and Environmental Engineering*, Vol. 45, pp. 1702-1714.
- Panuvatvanich A., Thammarat Koottatep and Kone D. Hydraulic behaviour of vertical-flow constructed wetland under different operating conditions. *Environmental Technology*, 10(30) 0-0, 2010.
- Panuvatvanich A., Thammarat Koottatep and Kone D. Influence of sand layer depth and percolate impounding regime on nitrogen transformation in vertical-flow constructed wetlands treating faecal sludge. *Water Research*, 10(43) 0-0, 2010.
- Pokasoowan C., Kanitchaidecha W., K.C. B.K. and Ajit Annachhatre. Investigation on laboratory and pilot-scale airlift sulfide oxidation reactor under varying sulfide loading rate. *Journal of Environmental Science and Health - Part A Toxic/Hazardous Substances and Environmental Engineering*, 1(44) 0-0, 2010.
- Pongkiatkul P., Nguyen Thi Kim Oanh, Wangkiat A. and Okamoto S. (2010), "Further Analysis and PMF Application to the Chemical Composition Data of IPCAJ's Kashima SPM study". *Int. J. Environment and Pollution*, Vol. 40, No. 4.
- Ponza S., Preeda Parkpian, Chongrak Polprasert, Shrestha R.P. and Jugsujinda A. Removal of trichloroethylene (TCE) contaminated soil using a two-stage anaerobic-aerobic composting technique. *Journal of Environmental Science and Health - Part A Toxic/Hazardous Substances and Environmental Engineering*, Vol. 45, pp. 549-559.
- Prem Ananth A., Prashanthini V. and C. Visvanathan. Healthcare Waste Management in Asia. *Waste Management*, 30, 154–161, 2010.
- Sangjun S., de Jong E., Nijmeijer S., Mutarapat T., Somsak Ruchirawat and Martin van den Berg. Induction of cell cycle arrest in human MCF-7 breast cancer cells by cis-stilbene derivatives related to VIOXX?. *Toxicology Letters*, 2(186) 0-0, 2010.
- Sarathai Y., Thammarat Koottatep and Morel A. Hydraulic characteristics of an anaerobic baffled reactor as onsite wastewater treatment system. *Journal of Environmental Sciences*, 9(22) 0-0, 2010.
- Seng B., Khanal S.K. and C. Visvanathan. Anaerobic digestion of waste activated sludge pretreated by a combined ultrasound and chemical process. *Environmental Technology*, 31; 3, 257-265, 2010
- Singhakant C., Thammarat Koottatep and Jutamaad Satayavivad. Enhanced arsenic removals through plant interactions in subsurface-flow constructed wetlands. *Journal of Environmental Science and Health - Part A Toxic/Hazardous Substances and Environmental Engineering*, 2(44) 0-0, 2010.
- Singhakant C., Thammarat Koottatep and Jutamaad Satayavivad. Fractional analysis of arsenic in subsurface-flow constructed wetlands with different length to depth ratios. *Water Science and Technology*, 7(60) 0-0, 2010.
- Sivakumaran S. and Toshiya Aramaki. Estimation of household water end use in Trincomalee, Sri Lanka. *Water International*, 1(35) 0-0, 2010.
- Subramanian R., Winijkul E., Bond T.C., Thiansathit W. and Nguyen Thi Kim Oanh. Climate-relevant properties of diesel particulate emissions: Results from a piggyback

- study in Bangkok, Thailand. Environmental Science and Technology, 11(43) 0-0, 2010.
- Sumith J.A., Preeda Parkpian and Leadprathom N. Dredging influenced sediment toxicity of endosulfan and lindane on black tiger shrimp (*Penaeus monodon* Fabricius) in Chantaburi River estuary in Thailand. International Journal of Sediment Research, Vol. 4 (24), pp. 649-663.
- Surinkul N. and Thammarat Koottatep. Advanced sanitation planning tool with health risk assessment: Case study of a peri-urban community in Thailand. Human and Ecological Risk Assessment, 5(15) 0-0, 2010.
- Swati M., Karthikeyan O.P., Joseph K., C. Visvanathan and Nagendran R. Pilot scale simulation of landfill bioreactor and controlled dumping of fresh and partially stabilized municipal solid waste in tropical developing country. Accepted for publication in Practice Periodical of Hazardous, Toxic and Radioactive Waste, ASCE Publication, 2010.
- Tangjarukij C., Zelikoff J.T. and Mathuros Ruchirawat. The effects of pyridoxine deficiency and supplementation on hematological profiles, lymphocyte function, and hepatic cytochrome P450 in B6C3F1 mice. Journal of Immunotoxicology, 3(6) 0-0, 2010.
- Thanh B.X. and C. Visvanathan. Emeritus Prof. Roger Ben Aim. Characterization of aerobic granular sludge at various organic loading rates. Process Biochemistry, 2(44) 0-0, 2010.
- Thanh B.X., Sperandio M., Guigui C., Ben Aim R., Wan J.F. and C. Visvanathan, (2010). Coupling sequencing batch airlift reactor (SBAR) and membrane filtration: Influence of nitrate removal on sludge characteristics, effluent quality and filterability, Desalination, 250, 850-854, 2010.
- Thawornchaisit U. and Chongrak Polprasert. Evaluation of phosphate fertilizers for the stabilization of cadmium in highly contaminated soils. Journal of Hazardous Materials, 1-3(165) 0-0, 2010.
- Thuithaisong C., Preeda Parkpian, Shipin O., Shrestha R.S., Naklang K., DeLaune R.D. and Jugsujinda A. Soil Quality Indicators for Predicting Sustainable Organic Rice Production. J. of Communications in Soil Science and Plant Analysis (in press).
- Tsuzuki Y., Thammarat Koottatep, Jiawkok S. and Saengpeng S. (2010). Municipal wastewater characteristics in Thailand and effects of "soft intervention" measures in households on pollutant discharge reduction. Water Science and Technology, Vol. 62, No. 2. pp. 231 – 244 doi: 10.2166/wst.2010.164
- Tsuzuki Y., Thammarat Koottatep, Wattanachira S., Sarathai Y. and Wongburana C. On-site treatment systems in the wastewater treatment plants (WWTPS) service areas in Thailand: Scenario based pollutant loads estimation. Journal of Global Environment Engineering, (14) 0-0, 2010.
- van D.T.H. and Nguyen Thi Kim Oanh. Open top chamber experiment study to assess effects of ground level ozone on local peanut cultivar in Vietnam. International Journal of Environmental Studies, 1(66) 0-0, 2010.
- Van D.T.H., Ishii S. and Nguyen Thi Kim Oanh. Assessment of ozone effects on local rice cultivar by portable ozone fumigation system in Hanoi, Vietnam. Environmental Monitoring and Assessment, 1-4(155) 0-0, 2010.
- Visoth T., Yim M., Vathna S., Irvine K. and Thammarat Koottatep (2010). Efficiency of Phnom Penh's Natural Wetlands in Treating Wastewater Discharges. Asian Journal of Water Environment and Pollution, IOS Press, Vol. 7, No. 3, pp. 39 - 48.
- Wickramasinghe S., Cochard R., Anceno A.J. and Oleg Shipin. Multi-functional pollution mitigation in a rehabilitated mangrove conservation area. Ecological Engineering, 5(35) 0-0, 2010.
- Wijekoon K.C., C. Visvanathan and Abeynayaka A. Effect of organic loading rate on VFA Production, organic matter removal and microbial activity of a two stage thermophilic anaerobic membrane bioreactor. Accepted in J of Bioresource Technology, 2011.
- Yajima A. and Thammarat Koottatep. Assessment of E. coli and Salmonella spp. infection risks associated with different fecal sludge disposal practices in Thailand. Journal of Water and Health, 2(8) 0-0, 2010.

Conference Publications

Abeynayaka A., Nguyen T., C. Visvanathan and Ariyamethee P. "Chemical-free and Carbon Neutral Membrane based Emergency Water Supply System", 8th International Symposium on Southeast Asian Water Environment, Phuket, Thailand. October 24 to 26, 2010. (This presentation won the "Award for Asian Young Professional on Water Research" as a recognition of most outstanding and promising performance in the symposium).

Abeynayaka A., Tuan L.A., C. Visvanathan, Yonekawa H. and Watanabe Y. "Pre-treatment options for hybrid ceramic microfiltration systems for surface water treatment", International Conference on Sustainable Built Environments (ICSBE-2010), Kandy, 13-14 December 2010.

Ajit P. Annachatre. Pollutants in Environment – How Well are They Managed in the Developing Countries?, National Conference "POLLUTECH 2010", J.N. Tata

Auditorium, IISC Campus, Bangalore, India, 28-30 October 2010.

C. Visvanathan, Wijekoon K.C. and Abeynayaka A. "Effect of organic loading rate on VFA production, organic matter removal and microbial activity of a two-stage thermophilic anaerobic membrane bioreactor" *Conference on Challenges in Environmental Science and Engineering 2010*, Cairns, Queensland, Australia, 26 September- 1 October, 2010.

C. Visvanathan. "Anaerobic Membrane Bioreactors: Current Status and Future Potentials", *International Conference on MBR for Wastewater Treatment*, Key Note Lecture, Bangkok, Thailand, 26-26 April, 2010

C. Visvanathan. "Challenges and Barriers for 3R Technology Transfer: Good and Bad Practices" Joint workshop of "Asian Resources Circulation Policy Research" and "ERIA 3R Policy Working Group", University of Malaya, Kuala Lumpur, Malaysia, 7-8 October, 2010.

C. Visvanathan. "Challenges and Opportunities with Green Technology Transfer on the 3R" Regional 3R forum in Asia, Kuala Lumpur, Malaysia, 4-6 October, 2010

C. Visvanathan. "Climate Change & Water Nexus: Gearing Academic Curriculum Towards Adaptation", *10th Science Council of Asia Conference*, 15-16 June, Manila, Philippines, 2010

C. Visvanathan. "Community, Public & Private Sector Synergy: How Effective to Improve SWM Service?", *7th Expert Meeting on Solid Waste Management in Asia and Pacific Islands*, 15-17 September, Taipei, Taiwan, 2010

C. Visvanathan. "Eco Industrial Networking of the Rice and Livestock Sector at Chachaengsao Province, Thailand", *International Conference*

on Cluster Economic Development, 26 February, ADB, Manila, Philippines, 2010.

Hearth G.B.B, Prem Ananth A. and C. Visvanathan. "Enhancing Environmental Sustainability in Dambulla Dedicated Economic Centre: Industrial Networking for Waste Management", *9th Asia Pacific Roundtable for Sustainable Consumption and Production*, Colombo, Sri Lanka, 10-12, June, 2010

Kijjanapanich P., Ajit P. Annachhatre and Piet Lens, Electron donors for treating acid mine drainage in permeable reactive barrier reactor, *2nd International Conference on Chalcogen Cycle Science and Technology*, Delft, The Netherlands, 22-27 May 2010.

Nguyen Thi kim Oanh and Leelasakultum K. Prediction of haze episode potential for mountain-valley urban area using synoptic-climatological modeling approach. *Proceedings of the HARMO 13 (13th conference on Harmonisation within Atmospheric Dispersion Modelling for Regulatory Purposes)*, Paris France, June 1-4, 2010.

Nguyen Thi Kim Oanh, Chongrak Polprasert, Kittipongvises S., Karstensen K.H., Dan N.P., Nghiem L.H., Chang-Chien. G.P. Characterization of Stack Emission from Simple Incinerator Burning PCB Contaminated Oil. *Proceedings of AWMA IT3 International Conference on Thermal Treatment Technologies and Waste Combustors*. San Francisco, May 17-20, 2010.

Rattanaoudom R. and C. Visvanathan. Removal of PFOA by Hybrid Membrane Filtration Using PAC and Hydrotalcite, *Conference on Challenges in Environmental Science and Engineering 2010*, Cairns, Queensland, Australia, 26 September- 1 October, 2010.

Thu L.N, C. Visvanathan, Phan C. and Ang M. Performance of *Mycobacterium Chlorophenolicum* Relative to Microorganism Isolated from Activated Sludge Treating Pentachlorophenol in MBR, *Chemeca 2010*, Adelaide, Australia, 26-29 September, 2010

Books and Monographs

Khan S.J. and C. Visvanathan. Fouling Mitigation Approaches in Membrane Bioreactor: Influence of hydrodynamic and physico-chemical approaches on fouling mitigation in a membrane bioreactor. VDM Verlag Dr. Müller, Germany. ISBN: 978-3-693-27831-6.

Book Chapters

Basnayake B.F.A. and C. Visvanathan. Solid Waste Management in Sri Lanka, in *Municipal Solid Waste Management in Asia and the Pacific Islands*, ISBN: 978-979-1344-78-4, Penerbit ITB, pp: 185-200, 2010

C. Visvanathan and Padmasri M. Water environment in Southeast Asia: Where do we stand today?, *Southeast Asian Waster Environment 4*, IWA publication, pp: 1- 10, ISBN: 184339362X, 2010.

C. Visvanathan. Bioenergy Production from organic fraction of municipal solid waste through dry anaerobic digestion, in *Bioenergy and Biofuel from Biowastes and Biomass*, ASCE publications, ISBN: 978-0-7844-1089-9, pp: 71-89, 2010.

Chiemchaisri C. and Weerasekara R., Joseph K., Kumar S. and C. Visvanathan. Application of Bioreactor Landfill Technology to Municipal Solid Waste Management: Asian Perspective. Impact, Monitoring and Management of Environmental Pollution, ISBN 978-1-60876-487-7, Nova Science Publishers, Inc. pp: 553-568, 2010.

Jegatheesan V., Shu L., and C. Visvanathan. Aquaculture effluent: Impacts and Remedies for Protecting Environment and Human Health, Encyclopedia of Environmental Health, Elsevier Publications, 2010.

Montangero A., Schaffner M., Surinkul N., Nguyen Viet H. and Thammarat Koottatep, Morel A., Lüthi C, Schertenleib R. Innovative tools for environmental sanitation planning and river basin management in Southeast Asia. In: Hurni H, Wiesmann U, editors; with an international group of co-editors. Global Change and Sustainable Development: A Synthesis of Regional Experiences from Research Partnerships. Perspectives of the Swiss National Centre of Competence in Research (NCCR) North-South, University of Bern, Vol. 5. Bern, Switzerland: Geographica Bernensia, pp 357–37

Morel A., Sarathai Y., Nguyen V.A. and Thammarat Koottatep. Potential and limitations of decentralised wastewater management in Southeast Asia. In: Hurni H, Wiesmann U, editors; with an international group of co-editors. Global Change and Sustainable Development: A Synthesis of Regional Experiences from Research Partnerships. Perspectives of the Swiss National Centre of Competence in Research (NCCR) North-South, University of Bern, Vol. 5. Bern, Switzerland: Geographica Bernensia, pp 343–356.

Thammarat Koottatep and Panuvatvanich A. Constructed Wetlands for Effective Wastewater Treatment. In: K. Irvine, T. Murphy, V. Vanchan, and S. Vermette (eds.). Water Resources and Development in Southeast Asia, Southeast Asia Center, NY, Pearson Learning Solutions, pp 179 – 192

Thammarat Koottatep. Dealing with sanitation, environmental dynamics and disparities: Research partnerships in Southeast Asia. In:

Hurni H, Wiesmann U, editors; with an international group of co-editors. Global Change and Sustainable Development: A Synthesis of Regional Experiences from Research Partnerships. Perspectives of the Swiss National Centre of Competence in Research (NCCR) North-South, University of Bern, Vol. 5. Bern, Switzerland: Geographica Bernensia, pp 331–341.

Papers in Workshops

Ajit P. Annachhatre. Networking under ARRPE – Cooperation in Science and Technology. Workshop of IROST AIT Agreement on Climate Change, IROST, Iran, 16-17 October 2010.

Ajit P. Annachhatre. Anammox Process for Wastewater Nitrogen Removal. Seminar given in ARI Laboratory, Pune India, 15 April 2010.

C. Visvanathan. Low Carbon Technologies for Pulp and Paper Sector, in National Workshop on Low Carbon Technology Innovation and Diffusion in Thai Manufacturing Sectors, organized by AIT and UNIDO, Century Park Hotel, Bangkok, 28 January 2010.

C. Visvanathan. Hazardous Solid Waste Management in Thailand: An Overview, in Workshop on “Sustainability of solid Waste Management in Thailand” organized by Joint Graduate School of Energy & Environment, KMUTT, Bangkok, 11 October, 2010.

C. Visvanathan. Towards Strategic Promotion of 3Rs in Developing Asia, Asia 3R High-Level Seminar, Tokyo, Japan, 9-10 March 2009.

Non-refereed Publications

C. Visvanathan. Decentralized Approach to Treating the Organic Fraction of Municipal Solid Waste with Energy Recovery by Using Inclined Dry Anaerobic Digestion,

published as engineering cases, in engineeringcases.knovelblogs.com.

Prem Ananth A. and C. Visvanathan. *How Can Solid Waste Management and 3R Contribute to Climate Change Mitigation?* ASEP Newsletter Vol 26 (4) Asian Society for Environmental Protection, Thailand, 2009.

Abstracts in international conferences

Agustian D. and Nguyen Thi kim Oanh. Black carbon emission inventory for Indonesia. Paper presented at the BAQ10 organized in Singapore, 9-11 Nov. 2010.

Changsuphan A. and Nguyen Thi kim Oanh. Removal of Benzene using nZnO Nano Particles Coated on Zeolite Absorbent Enhanced Ozone and UV. Paper presented at the BAQ10 organized in Singapore, 9-11, Nov. 2010.

Chaosakul T. Rajapakse E.P., Abeynayake A., Asokbunyara V., Pakdeerulthanami K., Tung T.V., Wint K.S., Khai T.Z., Bounmanyvone P., Tam H.T.T., Thammarat Koottatep and Irvine K.N. Experimental study of urban sediment size distribution, build-up and wash-off in a peri-urban area: A case study of Rattanakosin village, Thailand. Proc. of the 8th International Symposium on Southeast Asia Water Environment, Phuket, Thailand, pp. 144-149.

Iqbal A. and Nguyen Thi kim Oanh. Assessment of Acid Deposition in Bangladesh using Air Pollution Dispersion Modeling. International Symposium on “Benefiting from Earth Observation: Bridging the Data Gap for Adaptation to Climate Change in the Hindu Kush-Himalayan Region”, 4-6 October 2010, Kathmandu, Nepal.

Iqbal A. and Nguyen Thi kim Oanh. Assessment of Acid Deposition in Bangladesh using Air Pollution Dispersion Modelling. Paper presented at the BAQ10 organized in Singapore, 9-11, Nov. 2010.

Kanabkaew T. and Nguyen Thi Kim Oanh. Assessment of Aerosol influence on Atmospheric Properties using Ground- and Satellite- based Measurements. Paper presented at the BAQ10 organized in Singapore, 9-11, Nov. 2010.

Kanabkaew T. and Nguyen Thi kim Oanh. Assessment of Aerosol Influence on Atmospheric Properties using Integrated Ground-and Satellite-based Measurements. International Symposium on “Benefiting from Earth Observation: Bridging the Data Gap for Adaptation to Climate Change in the Hindu Kush-Himalayan Region”, 4-6 October 2010, Kathmandu, Nepal.

Leelasakultum K. and Nguyen Thi kim Oanh. Synoptic Climatological Approach for Predicting Haze Episode Potential and Refining AOT-PM10 Relationship for Exposure Assessment. Paper presented at the BAQ10 organized in Singapore, 9-11, Nov. 2010.

Nguyen Thi kim Oanh. Air Quality and Climate Co-benefits: Quantification Methods and Challenges. Paper presented (oral) at the BAQ10 organized in Singapore, 9-11, Nov. 2010.

Sarathai Y., Thammarat Koottatep and Irvine K.N. Field study on biodegradation for a combined sewer system in Thailand. Proc. of the 8th International Symposium on Southeast Asia Water Environment, Phuket, Thailand, pp. 163 - 168.

Invited Lectures and Keynote Addresses

C. Visvanathan and Prem Ananth A. Higher Education Needs for Solid Waste Management through 3R in Asian Developing Countries, invited lecture at International Conference on Raising Awareness of the Need for Environmental Protection: A Role for Higher Education” Hoa Sen University and An Giang University, Ho Chi Minh City, 21-23 July, 2010.

C. Visvanathan. Current Status of Municipal Wastewater Management in Thailand, invited lecture at Department of civil and Environmental Engineering and Management, Tohoku University, Japan, 10 March, 2010.

C. Visvanathan. Solid Waste and Climate Change: Perceptions and Possibilities, International Conference on Solid Waste Management, Key Note Lecture, – *WasteSafe 2009*, Khulna, Bangladesh, 9-10 November 2009.

Nguyen Thi Kim Oanh. The Inter-laboratory comparison for UNEP-Male’ Declaration acid monitoring network. Invited speaker for UNEP-Male’ Declaration MoC Meeting, Dehli, India, Nov, 2010.

Nguyen Thi Kim Oanh. Emission inventory for agricultural field burning. Invited lecture at the UNEP-Male’ Declaration 8th Regional Refresher’s training, Dehli, India, Nov, 2010.

Professional Trainings

C. Visvanathan. Organized national Training program on “Application of Membrane Technology for Water and Wastewater Treatment” in collaboration with HCMC University of Technology, 22 December, 2010.

C. Visvanathan. Presented a lecture on “Public Private Partnership in Water Sector” organized by NWTTI, Metropolitan Water Works, Bangkok, Thailand, 18 August – 9 September, 2010.

C. Visvanathan. Presented lecture series on “Design of Water Treatment Plant” organized by NWTTI, Metropolitan Water Works, Bangkok, Thailand, 22 June – 2 July, 2010.

C. Visvanathan. Designed and organized a national Cleaner Production training program for Ho Chi Minh City Environmental

Protection Agency (HEPA), 13-15 January, 2011.

Conferences, Seminars, and Workshops

Ajit P. Annachatre. Organized a workshop on “Management of Heavy Metal Discharges”, joint activity under ARRPET, UNAIT Office and SDCC/AIT-France Network, AIT, Thailand, 18-19 November 2010.

C. Visvanathan. Presented a lecture on “Water Supply and Sanitation for Disaster Response” in the training program “**Public Health and Disaster Management**”, organized by DPMM program from 6 - 18 December, 2010 in AIT.

C. Visvanathan. Organized a stakeholder workshop on “Sustainable Water Management in Urban Fringe Areas through Industrial Wastewater Reuse”, HCMC, Vietnam, 21 December, 2010.

C. Visvanathan. Organized a workshop on “Sustainable Urban Water Use and management in Organized a Consultative Workshop on Healthcare Waste Management in Lao PDR, Vientiane Capital, Lao PDR, 23 March 2010, Jointly with ADB and Ministry of Health Lao.

Nguyen Thi Kim Oanh. Organized the dissemination workshop of the AIT-RTG project “Air Quality and Climate Impacts of Switching to Natural Gas-Fueled Public Transportation Vehicles in Bangkok”. Cooperation with Dr. Rattapon Onchang, Silpakorn University. At SU, 20 July 2010.

5.5.7 Doctoral Students' Dissertation

Applications of Anaerobic Baffled Reactor (ABR) and Vermicomposting Process for Treating Household Wastewater and Accumulated Sludge

By Yuttachai Sarathai
Supervisor: Dr. Thammarat Koottatep

Development of Nitrogen Transformation Model for Vertical Flow Constructed Wetland Treating Faecal Sludge

By Atitaya Panuvatvanich
Supervisor: Dr. Thammarat Koottatep

Sulfur Production via a Biological Sulfide Oxidation Process

By Chanya Pokasoowan
Supervisor: Prof. Ajit Annachhatre

Environmental Toxicology, Technology & Management

Effects of Pesticides on the Non-Neuronal Lymphocytic Cholinergic System

By Tanvisith Charoenying
Supervisors: Dr. Jutamaad Satayavivad / Dr. Preeda Parkpian

Exposure to 1,3Butadine and its Possible Effects on Temple Workers and Traffic Policemen

By Manaswee Arayasiri
Supervisors: Dr. Khunying Mathuros Ruchirawat/Dr. Preeda Parkpian

Low Level Occupational Exposure to Styrene and Benzene: Its Effects on DNA Damage and DNA Repair

By Sirilak Wongvijitsuk
Supervisors: Dr. Khunying Mathuros Ruchirawat/Dr. Preeda Parkpian

Mercury Contamination and Potential Impacts from a Municipal Waste Incinerator on Samui Island, Thailand

By Dudsadee Muenhor
Supervisors: Dr. Preeda Parkpian / Dr. Jutamaad Satayavivad

5.5.8 Masters Students' Theses

Analysis and Quantification of Air Quality and Climate Co-Benefits for Coal-Fired Power Plants in China

By Jing Chen
Supervisor: Dr. Nguyen Thi Kim Oanh

Analysis of the Development of Strategic Environmental Assessment Process in the Tropical Developing Countries with Regard to Coastal and Riverine Water Environment

By Palwasha Achakzai
Supervisor: Dr. Oleg Shipin

Determination of Greenhouse Gas Emissions by Carbon Flow Analysis of Household Sanitation Practices

By Chanutsakul Supirak
Supervisor: Dr. Thammarat Koottatep

Assessment of Air Quality and Climate Co-benefit for Urban Public Transport: A Case Study of Bangkok Metropolitan Region

By Aue-Enndu Vilaiphorn
Supervisor: Prof. Nguyen Thi Kim Oanh

Continuous Cultivation of Microalgae Using Airlift Photo-Bioreactor

By Pham Dong Hai
Supervisor: Prof. Ajit Annachhatre

Cumulative Effect Assessment: Analysis of Interrelationships among Drivers (Stressors) and Valued Ecosystem Components in Multifunctional Tropical Wetlands

By Shirina Afroze
Supervisor: Dr. Oleg Shipin

Decomposition of Organic Wastes with Black Soldier Fly

By Nguyen Hong Dang
Supervisor: Dr. Thammarat Koottatep

Detection of Copper (II) Ion in an Aqueous Environment Employing Pyrazolidine Luminol (PL)

By Syarifah Hikmah Julinda Sari
Supervisor: Dr. Preeda Parkpian

Development of a Water Treatment System for Emergency Situations

By Nguyen Thi Thuy
Supervisor: Prof. Chettiappan Visvanathan

Development of Selected Aspects of the Decision-Making Tool of the Cumulative Effects Assessment : A Case Study of the Nam Ngum River Basin Wetlands, Lao PDR

By Phonepasong Sithideth
Supervisor: Dr. Oleg Shipin

Ecokinetics of Herbicides from Farmland to the River: A Case Study of Chanthaburi Estuary in Thailand

By Kitiya Totong
Supervisor: Dr. Jutamaad Satayavivad

Environmental and Human Health Risk Assessment due to Arsenic from Abandoned Tin Mining: A Case Study of Wiang Pa Pao, Chiangrai Province, Thailand

By Suntorn Uppamarn
Supervisor: Dr. Preeda Parkpian

Financial Analysis and Related Determinants in the Planning and Selection of Sanitation Technologies

By Chuthathip Siripong
Supervisor: Dr. Thammarat Koottatep

Greenhouse Gas Mitigation Potential from Starch Industries in Thailand

By Pateeya Katsin
Supervisor: Prof. Ajit P. Annachhatre

High Rate Thermophilic Anaerobic Membrane Bioreactor for Wastewater Treatment

By Kaushalya C. Wijekoon
Supervisor: Prof. Chettiappan Visvanathan

Investigation of Benzene Removal Mechanisms on Adsorbents Coated with Zinc Oxide Nanoparticles

By Muhammad Ikram B.A. Wahab
Supervisor: Prof. Nguyen Thi Kim Oanh

Mitigation of Cumulative Environmental Impacts on the Hoi An Estuarine Ecosystem with a Focus on the Truong Giang River (Quang Nam Province, Vietnam)

By Nguyen Hoang Yen
Supervisor: Dr. Oleg Shipin

Pathogen Flow Analysis and Potential Health Risks Due to Greywater Reuse in Thailand

By Tanya Udom
Supervisor: Dr. Thammarat Koottatep

Permeable Reactive Barrier for Remediation of Acid Mine Drainage

By Pimluck Kijjanapanich
Supervisor: Prof. Ajit P. Annachhatre

Pilot Scale Study on Surface Water Treatment Using Hybrid Ceramic Membrane Filtration System

By Sin Khanndarith
Supervisor: Prof. Chettiappan Visvanathan

Production of Biodiesel from Microalgae

By Nguyen Thi Thu
Supervisor: Prof. Ajit Annachhatre

Quantification of Mercury Containing Wastes and Management Practices in Thailand

By Nisita Khongpaitoon
Supervisor: Dr. Preeda Parkpian

Source Apportionment for Particulate Matter Air Quality Management of a Mining Town in Quang Ninh, Vietnam

By Nguyen Thanh Hang
Supervisor: Prof. Nguyen Thi Kim Oanh

Two-Stage Anaerobic Digestion for the Treatment of Dissolved Organic Fraction of Municipal Solid Waste

By Sheelva Shakya
Supervisor: Prof. Chettiyappan Visvanathan

Removal of Glyphosate and Paraquat from Agricultural Soil Using Vetiver Grass (Vetiveria sp.)

By Suthee Janyasuthiwong
Supervisor: Dr. Jutamaad Satayavivad

The Detection of Mercury (II) Ion in Aqueous Environment Based on Rhodamine Hydrazide Sensor

By Rojana Wiangpati
Supervisor: Dr. Preeda Parkpian

Assessment and development of design standards of Lao PDR's Healthcare Waste Management System:



Healthcare waste in Laos is not well managed due to several reasons. The government of Laos is finalizing a basic policy and plan for improving healthcare waste management across the country. In addition ADB in close consultation with the Laos Ministry of health is also preparing a grant assistance to finance the health sector in Laos. The project commissioned to AIT will study the healthcare waste situation in Laos and propose the design standards and systems for MOH in implanting the ADB grant program. The outcome of the study will set design standards for healthcare waste management facilities, opportunities for implementing 3R in healthcare waste streams and recommendations on healthcare waste treatment technologies.

5.6: SERD – FOOD ENGINEERING AND BIOPROCESS TECHNOLOGY FIELD OF STUDY

5.6.1 Introduction

This field of study focuses on value addition of agricultural commodities by the application of bioconversion in various sectors of industry and agriculture. These include food processing, aquaculture, cosmetics and health care. BPT focuses on the application of microorganism and enzymes to meet the demands of the developing countries of the region. FE focuses on the systems for handling, processing and storage of both durable and perishable food products in developing of small- scale food processing technologies. Emphasis is also placed on the determination of material properties; design and development of new processes and related equipment; and computer modeling and simulation of postharvest and food processing operations.

5.6.2 Faculty and Research Staff

Full-time Faculty

ATHAPOL NOOMHORM, BSc, Kasetsart Univ, Thailand; MEng, Lamar Univ, Texas; PhD, Louisiana State Univ, USA.

Professor and Coordinator
(*Agro-Industrial Development, Food Process Technology, Post Harvest Technology, Supply Chain*)

SUDIP KUMAR RAKSHIT, BSc, Loyola College; BTech, Jaavpur Univ, India; MTech, PhD, Indian Inst of Tech, India

Professor (*Biochemical Engineering and Biotechnology; Biopolymers and Lipid Biotechnology; Fermentation and Enzyme Technology; Food*

Biotechnology; Functional Foods)

Vice President for Research

ANIL KUMAR ANAL, DVM., University of Agriculture, Faisalabad, Pakistan; MSc. and PhD., AIT, Thailand

Assistant Professor (Food Engineering & Bioprocess Technology Field of Study (*Animal Biotechnology, Food and Pharmaceutical Biotechnology, Dairy and Meat Process Technology, Food Colloids and Biopolymer, Functional Foods, Micro-/Nanoencapsulation, Bionanotechnology*))

Associate Dean for Research & Outreach, School of Environment, Resources & Development

5.6.3 Grants and Sponsored Research Completed in 2010

AIT Support to National University (2007-2010)-Research

Duration: 01 Jun 07 - 31 Dec 10

Project Investigator(s): Sudip Kumar Rakshit
Sponsor: Swedish International Development Cooperation Agency, Sweden
Total Contracted Amount (THB): 3,252,400

Biofuel Production

Duration: 15 Oct 08 - 30 Oct 10

Project Investigator(s): Sudip Rakshit
Sponsor: RTG
Total Contracted Amount (THB): 900,000

Food Industry Innovation in Thailand

Duration: 01 Jan 08 - 30 Apr 10

Project Investigator(s): Sudip Kumar Rakshit
Sponsor: Food and Agriculture Organization
Total Contracted Amount (THB): 480,000

Production of Germinated Brown Rice using Thai Rice Variety (KMDL 105)

Duration: 01 Nov 08 - 30 Oct 10

Project Investigator(s): Athapol Noomhorm
Sponsor: RTG
Total Contracted Amount (THB): 820,000

Production of instant rice using combined microwave fluidized bed drying

Duration: 01 Nov 08 - 30 Nov 10

Project Investigator(s): Athapol Noomhorm
Sponsor: RTG
Total Contracted Amount (THB): 2,000,000

Sustainability workshop: Spreading awareness through intensive program on Sustainability

Duration: 01 Jul 09 - 31 Jan 10

Project Investigator(s): Athapol Noomhorm
Sponsor: University of Tokyo Japan
Total Contracted Amount (THB): 1,069,428

Teaching and Research

Duration: 01 Jan 10 - 31 Dec 10

Project Investigator(s): Anil Kumar Anal
Sponsor: SERD grant
Total Contracted Amount (THB): 60,000

Technology for Probiotic Production and Feed Formulation Containing Viable Beneficial Organisms for Enhanced Healthy Production

Duration: 01 Jun 07 - 30 Jun 10

Project Investigator(s): Sudip Kumar Rakshit
Sponsor: BIOTEC, NSTDA, RTG
Total Contracted Amount (THB): 107,000

5.6.4 On-going Grants and Sponsored Research

Development of Anti Fungal Acrylic Fibre for Novel Applications

Duration: 01 Jan 09 - 30 Jun 11

Project Investigator(s): Sudip Kumar Rakshit
Sponsor: Various
Total Contracted Amount (THB): 400,000

Green composites from Soy flour based plastic and Biofibers from agro-industrial byproducts

Duration: 01 Jul 09 - 30 Jun 11

Project Investigator(s): Athapol Noomhorm
Sponsor: RTG
Total Contracted Amount (THB): 978,000

International Conference on Innovations in Food Process Technology and Engineering 2008

Duration: 01 Aug 08 - 03 Mar 11

Project Investigator(s): Athapol Noomhorm
Sponsor: Participants
Total Contracted Amount (THB): 650,000

Networking with French speaking French, Vietnamese and Cambodian universities in the area of bioconversion of lignocellulose residues to ethanol

Duration: 01 Jan 08 - 28 Feb 11
 Project Investigator(s): Sudip Kumar Rakshit
 Sponsor: Agence Universitaire de la Francophonie (AUF)
 Total Contracted Amount (THB): 963,192

Production of Bio-Ethanol and Biomaterials from Oil Palm Biomass: A study of feedstock sustainability, technological efficiency and social applicability

Duration: 01 Oct 10 - 30 Sep 12
 Project Investigator(s): Sudip Rakshit
 Sponsor: SDCC AIT France Network
 Total Contracted Amount (THB): 1,440,000

Residues from Pulp and Paper Industries for Bio-ethanol Production

Duration: 13 Oct 09 - 12 Oct 11
 Project Investigator(s): Sudip K Rakshit
 Sponsor: RTG/DA Research Center Co Ltd
 Total Contracted Amount (THB): 2,000,000

5.6.5 Publications

International Journal Articles with Impact factor

Anil Kumar Anal; Microencapsulation and its Application in Delivery of Bioactive Compounds in Food Systems; *Innovative Science: Agriculture and Food Edition (1): 34-40; 2010*

Athapol Noomhorm, Sirisoontaralak P., Uraichuen J., Ahmad I.. Effects of pressurized carbon dioxide on controlling *Sitophilus zeamais* (Coleoptera: Curculionidae) and the quality of milled rice. *Journal of Stored Products Research*, 3(45) 0-0, 2010.

Chittapalo T., Athapol Noomhorm. Ultrasonic assisted alkali extraction of protein from defatted rice bran and properties of the protein concentrates. *International Journal of Food Science and Technology*, 9(44) 0-0, 2010.

Do H.T.T., Anceno A.J., Sudip K. Rakshit. Erratum to DNase I treated DNA-PCR based detection of food

pathogens immobilized by metal hydroxides (*World Journal of Microbiology and Biotechnology*, (2009), 25, 8, DOI: 10.1007/s11274-009-0031-5). *World Journal of Microbiology and Biotechnology*, 8(25) 0-0, 2010.

Do H.T.T., Anceno II A.J., Sudip K. Rakshit. DNase I treated DNA-PCR based detection of food pathogens immobilized by metal hydroxides. *World Journal of Microbiology and Biotechnology*, 8(25) 0-0, 2010.

Elizabeth A. Ogunlana , Athapol Noomhorm and Teerapol Silakul; *Alley Farming in Thailand Sustainability Journal* 2010, 2 (8), 2523-2540

Kosin B., Sudip K. Rakshit. Induction of heat tolerance in autochthonous and allochthonous thermotolerant probiotics for application to white shrimp feed. *Aquaculture*, 1-4(306) 0-0, 2010.

Maneerote J., Athapol Noomhorm, Athapol Noomhorm. Optimization of processing conditions to reduce oil uptake and enhance physico-chemical properties of deep fried rice crackers. *LWT - Food Science and Technology*, 4(42) 0-0, 2010.

Minh H.K.Q., Sudip K. Rakshit. Use of specific PCR-based molecular markers for discrimination, rapid analysis of purity and identification of six fragrant rice varieties. *International Journal of Food Science and Technology*, 10(44) 0-0, 2010.

Nobuntou W., Preeda Parkpian, Nguyen Thi Kim Oanh, Athapol Noomhorm, Delaune R.D.. Lead distribution and its potential risk to the environment: Lesson learned from environmental monitoring of abandon mine. *Journal of Environmental Science and Health - Part A Toxic/Hazardous Substances and Environmental Engineering*, 13(45) 0-0, 2010.

Plangpin.Pianpumepong and Athapol Noomhorm (2010) "Isolation of probiotic bacteria from turmeric (*Curcuma longa* Linn.) and its application in enriched beverages" *International Journal of Food Science and Technology*. 45, 2456-2462; 2010

Wangtueai S., Athapol Noomhorm. Processing optimization and characterization of gelatin from lizardfish (*Saurida* spp.) scales. *LWT - Food Science and Technology*, 4(42) 0-0, 2010.

Waranusast R., Peter Haddawy, Athapol Noomhorm. Segmentation of text and non-text in on-line handwritten patient record based on spatio-temporal analysis. *Lecture Notes in Computer Science (including subseries Lecture Notes in Artificial Intelligence and Lecture Notes in Bioinformatics)*, (5651) 0-0, 2010.

Book

Vilai Rungsardthong, Maunmai Apintanopong, Natta Laohakunjit, **Anil Kumar Anal**; In: *Advances in Odor and Flavor Science: A Review on Aroma Applications in Food Products*; Edited by **Athapol Noomhorm**, Imran Ahmad; LAP LAMBERT ACADEMIC Publishing GmbH & Co. KG, Germany, ISBN: 978-3-8433-8034-8; 2010

Book Chapters

Anil Kumar Anal; *Controlled-Release Dosage Forms*; In: *Pharmaceutical Sciences Encyclopedia: Drug Discovery, Development and Manufacturing*; John Wiley and Sons Publishers, Hoboken, NJ, USA.

Conference Proceedings and Abstracts

Anil Kumar Anal; *Climate Change and Microbial Ecology: Possible Impacts on Food Safety*; In: *Proceedings, International Conference on Biodiversity, Livelihood and Climate*

Change in the Himalayas; CC-23; 2010.

Athapol Noomhorm (2010); Study on quality grading of mangosteen by ultrasonic specific gravity controlling system; Paper presented at the 5th International Conference on Innovations in Food & Bioprocess Technology (IFBT 2010), 7-9 December 2010; AIT Bangkok. Athapol Noomhorm; Study of electrical properties as dry weight determination of durian; Paper presented at the 5th International Conference on Innovations in Food & Bioprocess Technology (IFBT 2010), 7-9 December 2010; AIT Bangkok

Ekkapong Cheevitsopon and Athapol Noomhorm (2010): Changes in physiochemical property of germinated brown rice and parboiled germinated brown rice dried in a fluidized bed dryer; Paper presented at the 5th International Conference on Innovations in Food & Bioprocess Technology (IFBT 2010), 7-9 December 2010; AIT Bangkok.

Ho Minh Thao and A. Noomhorm (2010): Physiochemical properties of sweet potato and mung bean starch, and their blends for noodle production; Proceedings: 5th International Conference on Innovations in Food & Bioprocess Technology (IFBT 2010), 7-9 December 2010; AIT Bangkok.

Ho Minh Thao and Athapol Noomhorm (2010): Modeling and effects of various drying methods on sweet potato starch properties; Paper presented at the 5th International Conference on Innovations in Food & Bioprocess Technology (IFBT 2010), 7-9 December 2010; AIT Bangkok

Jiraporn Sripinyowanich and Athapol Noomhorm (2010): A new model for vibro-fluidized bed and microwave vibro-fluidized bed drying of unfrozen and frozen cooked rice:

Paper presented at the 5th International Conference on Innovations in Food & Bioprocess Technology (IFBT 2010), 7-9 December 2010; AIT Bangkok.

Melada Supakijnoraset & Anil Kumar Anal; Antimicrobial Activity of *Lactobacillus plantarum* and *Lactobacillus casei* to Inhibit the Food-borne Pathogens; Paper presented at the 5th International Conference on Innovations in Food & Bioprocess Technology (IFBT 2010), 7-9 December 2010; AIT Bangkok

Nattriya Supmoon and Athapol Noomhorm (2010); Design and development of an evaporative cooling system for tropical fruits and vegetables in transport vehicle; Paper presented at the 5th International Conference on Innovations in Food & Bioprocess Technology (IFBT 2010), 7-9 December 2010; AIT Bangkok

Orawan Sapanattayanon and Athapol Noomhorm (2010) Determination of a suitable thin layer drying model for coconut residue: Paper presented at the 5th International Conference on Innovations in Food & Bioprocess Technology (IFBT 2010), 7-9 December 2010; AIT Bangkok

Paweena Saeanghirunwattana and Athapol Noomhorm (2010); Improvement the performance of biocomposite (PLA-soy protein) reinforced with corn husk fiber; Paper presented at the 5th International Conference on Innovations in Food & Bioprocess Technology (IFBT 2010), 7-9 December 2010; AIT Bangkok

Sayali M. Yenkar, Arindam Haldar & Anil Kumar Anal; Ionotropic Cross-linked Multilayer Emulsions for Encapsulation of Fish Oil; Paper presented at the 5th International Conference on Innovations in Food & Bioprocess Technology (IFBT

2010), 7-9 December 2010; AIT Bangkok

Theradetch Lervilaianunt and Athapol Noomhorm (2010); The effect of operating conditions on pomegranate juice quality during ohmic heating process: Paper presented at the 5th International Conference on Innovations in Food & Bioprocess Technology (IFBT 2010), 7-9 December 2010; AIT Bangkok

5.6.6 Doctoral Students' Dissertation

Identification and Quantification of Fragrant Genes of Different Rice Varieties Using PCR

By Mr. Ho Ky Quang Minh
Supervisor: Prof. S.K. Rakshit

Production of Pineapple Juice Concentrate by Microwave Vacuum Evaporation

By Rittichai Assavarachan
Supervisor: Prof. Athapol Noomhorm

Ultrasonic Alkaline Assisted Extraction of Protein from Defatted Rice Bran and its Properties and Applications

By Thutiyaporn Chittapalo
Supervisor: Prof. Athapol Noomhorm

5.6.7 Masters Students' Theses and Research Studies

Addition of Hydrocolloids into Frozen Dough and its Effect on Bread Quality

By Apiluck Apiwatanant
Supervisor: Prof. Athapol Noomhorm

Application of Induction Heating and Vacuum Frying Technology for Developing Fried Pineapple Chips

By Auttawich Rintaravitoon
Supervisor: Prof. Sudip K. Rakshit

Biodiesel Production from Palm Oil Using Heterogeneous Catalysts CaO and CaO/Al₂O₃

By Mr. Wittavat Chaiwong
Supervisor: Prof. Sudip K. Rakshit

Co-fermentation of Hexose and Pentose Sugars Simulating Lignocellulosic Hydrolysates for Bio-ethanol Production

By Luu Huyen Trang
Supervisor: Prof. Sudip K. Rakshit

Combination of Vacuum Precooling and Modified Atmosphere Packaging on Extending the Shelf-Life of Holy Basil (*Ocimum sanctum L.*) in Mixed Herb Packaging

By Sirinan Lasricharn
Supervisor: Prof. Athapol Noomhorm

Comparison of Conventional and Microwave Frying of Chicken Nuggets and Jackfruit Chips

By Kanokwan Chinsri
Supervisor: Prof. Athapol Noomhorm

Determination Parameter and Mathematical Model Verification of Temperature Rise During Ohmic Pasteurization of Mixed Orange-Carrot Juice

By Widyasanti Asri
Supervisor: Prof. Athapol Noomhorm

Effect of Drying Methods on the Qualities of Pomegranate Arils (*Punica granatum L.*)

By Kingkan Pongtong
Supervisor: Prof. Athapol Noomhorm

Effect of Drying Temperature and Extraction Methods on Alpha-Mangostin Content from Pericarp of Mangosteen (*Garcinia mangostana*)

By Waritha Satong-aun
Supervisor: Prof. Athapol Noomhorm

Effect of Extraction Processes on the Quality of Roselle (*Hibiscus sabdariffa L.*) Antioxidants

By Niranut Khua-oua
Supervisor: Prof. Athapol Noomhorm

Effect of Ohmic Heating on the Preparation of Fermented Bamboo Shoot (*Thyrsostachys siamensis*)

By Napaporn Sreewilai
Supervisor: Prof. Athapol Noomhorm

Effect of Soxhlet Extraction and Canning Method on Physical Properties and Charantin Content of Bitter Melon (*Momordica Charantia*) Drink

By Rinnawat Chaijalearn
Supervisor: Dr. Anil Kumar Anal

Effects of Chitosan on Enhancing the Shelf Life of Fresh Rice Noodle

By Rungnapa Kallapruet
Supervisor: Dr. Anil Kumar Anal

Effects of Different Blanching Pretreatments and Drying Methods on the Qualities of Dried Rang Chuet (*Thunbergia laurifolia Lindl.*) Leaves and Tea Infusion

By Thitiworn Rattanathitikul
Supervisor: Prof. Athapol Noomhorm

Effects of Drying and Extraction Condition on Bioactive Compounds and Antioxidant Activity Obtained from Mahogany Fruit (*S. macrophylla*)

By Hussaya Northongkam
Supervisor: Prof. Athapol Noomhorm

Effects of Drying and Extraction Methods on Total Phenolic Content in Pomegranate Peel

By Phiangkamol Ngamwongkul
Supervisor: Prof. Athapol Noomhorm

Effects of Drying Methods on Sweetpotato Starch Properties and its Substitution for Mung Bean Noodles

By Ho Minh Thao
Supervisor: Prof. Athapol Noomhorm

Effects of Processing Conditions on the Quality of Quick Cooking Brown Rice

By Siwadol Sukjitam
Supervisor: Prof. Athapol Noomhorm

Evaluation of Postharvest Handling for Two Culinary Herbs: Sweet Basil (*Ocimum basilicum*) and Rocket Salad (*Diplotaxis tenuifolia*)

By Sukrit Termsaithong
Supervisor: Prof. Athapol Noomhorm

Extraction, Characterization and Application of Phenolics from Cinnamon Barks and Banana Peels

By Sirorat Jaisanti
Supervisor: Dr. Anil Kumar Anal

Improving the Performance of Biocomposites (Pla-Soy Protein) Reinforced with Corn Husk Fiber

By Paweena Saenghirunwattana
Supervisor: Prof. Athapol Noomhorm

New Pretreatment Methods for Lignocellulosic Residue for Second Generation Bioethanol Production

By Yadhu Nath Guragain
Supervisor: Prof. Sudip K. Rakshit

Optimization of Inulin Extraction from Jerusalem Artichoke Tubers (*Helianthus tuberosus L.*)

By Kanitta Wangdee
Supervisor: Prof. Athapol Noomhorm

Preparation and Characteristic of Pyrodextrins from Waxy Rice Starch

By Vorada Assavatanalab
Supervisor: Prof. Athapol Noomhorm

Quality of White Salted Noodles Prepared by Partial Substitution of Wheat Flour by Jackfruit Seed (*Artocarpus heterohyllus Lam*) Flour

By Khemawan Sukondhasingh
Supervisor: Prof. Athapol Noomhorm

Reduction of Oil Contents in Potato Crisps with Sugar Pre-Treatment

By Chotika Ounseng
Supervisor: Dr. Anil Kumar Anal

Reinforced Cassava Starch Based Edible Film with Essential Oil and Clay Nanoparticles

By Butsadee Iamareerat
Supervisor: Dr. Anil Kumar Anal

Soy Protein Isolate-Essential Oils Based Edible Film for Food Packaging

By Supusanee Dulyakasem
Supervisor: Dr. Anil Kumar Anal

The Effect of Batter Containing Granular Cold-Water-Soluble Rice Flour on the Properties of Deep Fried-Onion Rings

By Natchaya Vatcharasuwan
Supervisor: Prof. Athapol Noomhorm

The Effect of Frying Conditions on Puffed Germinated Purple Rice

By Ampa Somsak
Supervisor: Prof. Sudip K. Rakshit

Utilization of Eucalyptus Wood Tops for the Production of Bio-Ethanol

By Paphawee Nantarajit
Supervisor: Prof. Sudip K. Rakshit

Whey Protein Concentrate-Polysaccharides Based Microcapsules for Controlled Release of Folic Acid

By Nongnard Jaroensri
Supervisor: Dr. Anil Kumar Anal

Research Study: Antioxidant and Antimicrobial Activity of Ultrasonic-Assisted Extracts of Local Longan Fruit Peel

By Zia Ur Rehman

Supervisor: Prof. Sudip K. Rakshit

Research Study: Prevalence of Salmonella and Escherichia coli in the Poultry Meat of Thailand and the Study of their Antibigram

By Ali Akbar

Supervisor: Dr. Anil Kumar Anal



Production of Instant Rice using Combined Microwave Vibro-Fluidized Bed Drying

The main aim of this project is to add the value of Thai rice and increase the competitiveness of Thai food manufacturers by developing a process for the preparation of instant rice. A new hybrid dryer, that is the single-mode applicator microwave-assisted vibro-fluidized bed (SMA-MVFB) dryer (Figure above), was designed and fabricated for the instant rice production purpose. Three drying factors, including pre-drying treatment (with and without freezing), microwave-assisted drying (SMA-MVFB and without microwave-assisted drying, that is vibro-fluidized bed (VFB)), and drying temperatures (110-185°C), were varied to investigate their relative effects on drying characteristics of cooked rice, energy consumption during drying, and instant rice quality. According to the study on production of instant rice using the lab-scale SMA-MVFB dryer, the best quality of instant rice products was achieved when drying cooked rice in a system of VFB. Therefore, the pilot-scale VFB drying machine was designed and fabricated in order to scale up the production capacity to be 25 kg/h.

5.7: SERD – GENDER AND DEVELOPMENT STUDIES FIELD OF STUDY



5.7.1 Introduction

A small project, Women in Development was initiated in the Human Settlements Development Division at AIT in the late 1980s. This grew into the Gender and Development Studies (GDS) as an academic unit in 1991, with financial support from CIDA, NORAD, the Dutch Development Cooperation and the Japanese Government.

Gender and Development Studies (GDS) is a center for graduate studies, research and outreach in the School of Environment, Resources and Development. Within the overall gender specific framework, GDS highlights both the need for specialized academic degree awarding studies in gender and development, and the integration of gender analysis and a gender relations perspective in AIT's other fields of study.

5.7.2 Faculty and Research Staff

Full-time Faculty

BERNADETTE RESURRECCION, BSc, Assumption College, Philippines; MA, PhD, Inst of Social Studies, the Hague, the Netherlands.

Associate Professor and Field Coordinator (*Gender, natural resource management and climate change, multi-local livelihoods and migration, discourses and practices of gender mainstreaming*)

KYOKO KUSAKABE, BA, Sophia University, Tokyo, Japan; MSc, PhD, AIT, Thailand.

Associate Professor (*Women's employment in informal economy; Labor migration, Cross-border trade; Gender and development policy and planning; Gender issues in fisheries/aquaculture.*)

PHILIPPE DONEYS, B.A., University of Toronto, Canada; MA, University of London, UK; PhD, Institut d'Etudes Politiques de Paris, France.

Assistant Professor (*New Technologies, Industrialization and Gender HIV/AIDS; Gender Politics, Civil Society and Human Rights; Gender, Migration and Trafficking in Asia*)

Visiting Faculty

DONNA L. DOANE, M. A. Anthropology, M.A., M. Phil. Economics, Yale University, and Ph.D. Economics, Yale University

Adjunct Faculty (*Economic Development, Gender and Development, Informal economy, home based work, social protection, technology policies, indigenous knowledge and technology blending, analyses of prejudice and discrimination, conflict, ethnicity and gender*)

JULAIKHA BENTE HOSSAIN, MSc in University of Dhaka, Bangladesh; MSc. and PhD in Asian Institute of Technology, Thailand

Research Specialist and Visiting Faculty (*Gender and Development with emphasis on the policies and programmes for gender equality and women's empowerment; Gender, Employment and Organization; Gender and ICT for Development; Gender and Human Rights; Gender, Development and Public Policy; Gender Mainstreaming; Gender and Natural Resource Management*)

Research Staff

JULAIKHA BENTE HOSSAIN, MSc in University of Dhaka, Bangladesh; MSc. and PhD in Asian Institute of Technology, Thailand

Research Specialist and Visiting Faculty (*Gender and Development with emphasis on the policies and programmes for gender equality and women's empowerment; Gender, Employment and Organization; Gender and ICT for Development; Gender and Human Rights; Gender, Development and Public Policy; Gender mainstreaming; Gender and Natural Resource Management*)

LENA STHAPIT, MSc. in Asian Institute of Technology, Thailand

Project Manager (*Enabling Bio-innovation for Poverty Alleviation in Asia*)

KANOKPORN JAROENRITH, M.SW. in Education, Thammasat University, Thailand

Research Associate (*Capacity Building for Gender, poverty and Mobility Analysis of Road Transportation Development in Greater Mekong sub-Region Project supported by ASEAN Foundation*)

JAGRITI SHANKAR, MSc in Asian Institute of Technology, Thailand

Project Officer (*Asian Project Management support Programme-Gender Sensitive Management*)

DUANGSAMORN JATUPORNPIMOL, MSc in Asian Institute of Technology, Thailand

Research Associate (*Responding to the Feminization of AIDS: Gender Power dynamics in marriage and Sero discordant Relationships implications for practice, Thailand*)

5.7.3 Grants and Sponsored Research Completed in 2010

Capacity Building Workshop on Gender and Macroeconomic Issues

Duration: 01 Apr 10 - 30 Sep 10
Project Investigator(s): Kyoko Kusakabe
Sponsor: UNDP Bangkok
Total Contracted Amount (THB): 320,000

Gender and Sustainable Development: Natural Resource Management, Migration and Multi-local Livelihoods

Duration: 01 Dec 07 - 01 Aug 10
Project Investigator(s): Bernadette Resurreccion
Sponsor: European Commission
Total Contracted Amount (THB): 3,098,103

International Workshop on Gender Migrant workers and Citizenship in GMS: Economic and Political perspectives for a world in Crisis

Duration: 01 May 09 - 31 Mar 10
Project Investigator(s): Kyoko Kusakabe
Sponsor: Japan Foundation
Total Contracted Amount (THB): 572,600

Socially and Gender Responsive Natural Resource Management in the Context of the Biodiversity Conservation Corridors Initiative Project

Duration: 01 Jul 08 - 30 Apr 10
Project Investigator(s): Julaiikha B Hossain
Sponsor: Asian Development Bank
Total Contracted Amount (THB): 3,400,000

5.7.4 On-going Grants and Sponsored Research

Asian Project Management support Programme-Gender Sensitive Management

Duration: 28 Apr 10 - 30 Jun 12
Project Investigator(s): Kyoko Kusakabe, Philippe Doney
Sponsor: IFAD
Total Contracted Amount (THB): 6,400,000

Capacity Building for Gender, Poverty and Mobility Analysis of Road Transportation Development in the GMS Region

Duration: 01 Jan 08 - 30 Jun 11
Project Investigator(s): Kyoko Kusakabe
Sponsor: ASEAN Foundation
Total Contracted Amount (THB): 10,889,238

Enabling Bio-innovation for poverty alleviation in Asia

Duration: 08 Mar 08 - 31 Dec 11
Project Investigator(s): Sudip Rakshit (33%), Bernadette Resurreccion (33%), Edsel Sajor (33%)
Sponsor: International Development Research Centre, Canada
Total Contracted Amount (THB): 17,232,280

Gender Analysis of Cross Border Road Infrastructure: A case of Kunming Bangkok Highway

Duration: 01 Dec 09 - 31 Mar 11
Project Investigator(s): Kyoko Kusakabe
Sponsor: ADB
Total Contracted Amount (THB): 1,000,500

Gender, Cross Border Migrant Workers and Citizenship- A Case Study of the Burmese-Thai Border

Duration: 01 Nov 06 - 28 Feb 11
Project Investigator(s): Kyoko Kusakabe
Sponsor: IDRC
Total Contracted Amount (THB): 10,559,630

Mobile Livelihoods and Gendered citizenship: The counter geographies of Indigenous people: China

Duration: 01 Jan 10 - 31 Jan 13
Project Investigator(s): Kyoko Kusakabe
Sponsor: Norwegian University of Science and Technology (NTNU)
Total Contracted Amount (THB): 2,118,670

Mobile Livelihoods and Gendered citizenship: The counter geographies of Indigenous people: Laos

Duration: 01 Jan 10 - 31 Jan 13
Project Investigator(s): Kyoko Kusakabe
Sponsor: Norwegian University of Science and Technology (NTNU)
Total Contracted Amount (THB): 2,764,032

M-Power Research Fund

Duration: 01 Jan 07 - 31 Dec 11

Project Investigator(s): Bernadette Resurreccion, Edsel Sajor

Sponsor: Mekong Program on Water, Environment and Resilience (M-Power)

Total Contracted Amount (THB): 732,600

NORAD-GDS 2006-2009

Duration: 01 Jan 06 - 31 Mar 11

Project Investigator(s): Bernadette Resurreccion, Philippe Doney, Kyoko Kusakabe

Sponsor: NORAD

Total Contracted Amount (THB): 20,781,377

Responding to the Feminization of AIDS: Gender Power dynamics in marriage and Sero discordant Relationships implications for practice, Thailand

Duration: 01 Aug 10 - 31 Jan 11

Project Investigator(s): Philippe Doney

Sponsor: UNIFEM

Total Contracted Amount (THB): 1,128,050

5.7.5 Publications**International Journal Articles with Impact factor**

Bernadette P. Resurreccion. Beyond cloak words toolkits and gender myths: gender environment and developments and integrative learning at the Asian institute of Technology. *Gender, Technology and Development*, 1(14) 0-0, 2010.

Dhungana, Bishnu Maya and Kyoko Kusakabe (2010) "Role of Self-Help Groups in Disabled Women's Empowerment: Case Study of Kathmandu Valley Nepal", *Development in Practice*, 20:7, 855-865.

Groves G.E.C., Bernadette P. Resurreccion, Philippe Doney. Keeping the peace is not enough: Human security and gender-based violence during the transitional period of Timor-Leste. *Sojourn*, 2(24) 0-0, 2010.

Julaikha B. Hossain. Networking with Norwegian institutions: Re-visiting, re-thinking gender in development. *Gender, Technology and Development*, 3(13) 0-0, 2010.

Kusakabe, Kyoko (2010) Viewpoints, *Natural Resources Forum*, 34, 328.

Kusakabe, Kyoko and Ruth Pearson (2010) "Transborder migration, social reproduction and economic development: A case study of Burmese women workers in Thailand", *International Migration*, 48:6, 13-43.

Kusakabe, Kyoko and Theonakhet Saphakdy (2010) "Constructed 'needs' for road construction: A case of Attapeu Province, Lao PDR", *GEMC Journal*, No.2, pp. 6-15, Tohoku University.

Kyoko Kusakabe, Pearson R.. International workshop on gender, migrant workers and citizenship in Greater Mekong Subregion: Economic and political perspectives for a world in crisis. *Gender, Technology and Development*, 2(13) 0-0, 2010.

Oo Z.M., Kyoko Kusakabe. Motherhood and social network: Response strategies of internally displaced Karen women in Taungoo district. *Women's Studies International Forum*, 5(33) 0-0, 2010.

Resurreccion, Bernadette and Sajor, Edsel E. "Not a real worker": Gendering migrants in Thailand's shrimp farms. *International Migration*, 48(6) 102-131, (2010)

Tran Ha Nguyen, Truong T.-D., Bernadette P. Resurreccion. Gender, class and nation in a transnational community: Practices of identity among undocumented migrant workers from Vietnam in Bangkok. *Gender, Technology and Development*, 3(12) 0-0, 2010.

Monographs

Kusakabe, Kyoko and Jubaiya Jahan (eds) (2010) *Gender mainstreaming in urban environmental management projects: Lessons learned from Southeast Asia Urban Environmental*

Management Applications (SEA-UEMA) Project, SEA-UEMA Project, AIT, Thailand.

Ouk Chansopheap, Suryaputrianita Satyanugraha and Kyoko Kusakabe (2010) *Micro-vendors' association's leadership in the development of a solid waste management system in DaemKor Market, Phnom Penh – a process documentation*, Southeast Asia Urban Environmental Management Applications Project, JAR Monograph no.6, AIT, Thailand.

Chapter in reports

Kusakabe, Kyoko (2010) "Social protection: The role of state, market, and community" In *Social protection and gender in Asia*, The International Society for Gender Studies, Japan.

Other publications

Kusakabe, Kyoko (2010) "Gender dimensions of rural mobility under climate change", *IFRTD Forum News* 14:4, February, London.

5.7.6 Doctoral Student's Dissertation

Gender, Access to Community Telecenter and Livelihood Asset Changes

By Sani Naivinit

Supervisor: Dr. Philippe Doney

Return Migration, Social Remittances and Collective Action for Water Supply and Road Building: Gender Dynamics in a Chinese Village

By Ge Jinghua

Supervisor: Dr. Bernadette P. Resurreccion

5.7.7 Masters Students' Theses and Research Studies

"Being Sherpa ": A Study of Gender and Ethnic Identities in Mountain Tourism in the Everest Region in Nepal

By Krishma Sharma

Supervisor: Dr. Bernadette P. Resurreccion

Combating Labour Trafficking in Thailand: Practical Implications of State Response

By Isssiree Reungpoj

Supervisor: Dr. Philippe Doney

Community Currency in Working from Home Environment: A Case Study of eHomemakers' Malaysia

By Sunitha Bisan

Supervisor: Dr. Kyoko Kusakabe

Early Impacts of New Land Registration System on a "Matrilineal" Society: The Case of Manatuto District, Timor-Leste

By Santana Soares

Supervisor: Dr. Bernadette P. Resurreccion

Economic Empowerment of Home-Based Women Entrepreneurs: A Case Study of Fish Processors in Cambodia

By Chea Pisey

Supervisor: Dr. Kyoko Kusakabe

Gender and Adaptive Strategies in Monga Affected Rural Bangladesh

By Musarrat Homaira

Supervisor: Dr. Bernadette P. Resurreccion

Gender and Disaster Response: A Case of Cyclone SIDR Bangladesh

By Sathi Rani Saha

Supervisor: Dr. Philippe Doney

Gender Dimension of Nepalese Men and Women Migrants in Australia

By Nila Sharma

Supervisor: Dr. Kyoko Kusakabe

Gender Dimensions of Decentralization: A Case Study of Bandung District and Cimahi Municipality, West Java Province, Indonesia

By Repelita Tambunan

Supervisor: Dr. Philippe Doney

ICTs in Flood Vulnerability Mitigation and its Impacts on Rural Livelihoods: Gender and Ethnic Dimensions in Ratanakiri Province, Cambodia

By Sreng Sopheap

Supervisor: Dr. Bernadette P. Resurreccion

Negotiating the Trade Route at the Border: A Case Study of Women Small Scale Cross-Border Traders in Myitkyina, Myanmar

By Khin Hnin Phyu

Supervisor: Dr. Kyoko Kusakabe

Pangalawat, A Food Sharing System among the Upland Higaonon Community of Agrulawon-Mintapod Ancestral Domain (Cumadon) in Northern Mindanao: Its Implication on Rural Sustainable Natural Resource Livelihoods from a Gender Perspective

By Pablo Merina Salengua

Supervisor: Dr. Bernadette P. Resurreccion

Research on Exploring Changes in the Lives of Home-Based Women Workers through Empowerment: A Gender Perspective

By Tahmina Naznin

Supervisor: Dr. Bernadette P. Resurreccion

State Response to Intimate Partner Violence in Thailand

By Duangsamorn Jatupornpimol

Supervisor: Dr. Philippe Doney

Women's Labour Migration in Uzbekistan: Decision Making Processes and Vulnerabilities in Destination Places

By Dilrabo Hamdamova

Supervisor: Dr. Bernadette P. Resurreccion

Research Study: Oppression of Women, Fear of Change and Need for Survival: A Case Study of Conflict-Induced Internally Displaced Persons in District Jafarabad, Balochistan, Pakistan

By Aurangzaib Alizai

Supervisor: Dr. Kyoko Kusakabe

5.8: SERD – NATURAL RESOURCES MANAGEMENT FIELD OF STUDY

5.8.1 Introduction

This field of study emphasizes natural resources, including land, forest and wild animal, and environmental conservation concerns. It addresses the problems of deforestation, land and coastal ecosystem degradation, biodiversity depletion, diminishing water supply, and other environmental pressures and threats on local, national, regional and global ecosystems.

5.8.2 Faculty and Research Staff

Full-time Faculty

GANESH P SHIVAKOTI, BS, MS, Udaipur Univ, India; PhD, Michigan State Univ, USA.

Professor (*Natural Resources Economics; Common Property Resources; NRM Policy Analysis; and Watershed Management*)

RAJENDRA P SHRESTHA, BSc, Haryana Agri. Univ, India; MSc, DTechSc, AIT, Thailand.

Associate Professor (*Sustainable Land Management; Natural Resources Degradation and Environmental indicators; Landuse-climate, Geoinformatics*)

ROLAND COCHARD, Ph.D., ETH, Switzerland

Assistant Professor (*Savanna ecosystem dynamics, landscape ecology, biodiversity, mangrove, risk management*)

Visiting Faculty

SYLVAIN PERRET, MS and PhD, University of Montpellier III, France; DSc, Ecole Polytechnique de Lorraine, Nancy, France.

Visiting Associate Professor (*Water management/institutions, governance, economics/sustainability in rural development/dynamic modeling*)

DAMIEN JOURDAIN, BEng, MSc, Ecole Nationale Supérieure Agronomique Montpellier, France; PhD, University of Montpellier I, France

Visiting Assistant Professor [*Agricultural Economics; Natural Resource Economics; Watershed Management; Ecosystem Services*]

Adjunct Faculty

DIETRICH SCHMIDT-VOGT, BSc, Freiburg University, Germany; MSc, University of Saskatoon, Canada; PhD, Heidelberg University, Germany.

Adjunct Faculty (*Landscape Ecology; Integrated Land Use Systems; Sustainable Forest Management; and Human Impact on Vegetation*)

EDWARD L WEBB, BA, Occidental College, Los Angeles; PhD, Univ of Miami, USA.

Adjunct Associate Professor (*Tropical Forest Ecology; Community-based natural resources management, and Forestry*)

5.8.3 Grants and Sponsored Research Completed in 2010

AIT Support to National University (2007-2010)-Curriculum Development

Duration: 01 May 07 - 31 Dec 10
Project Investigator(s): Dietrich Schmidt-Vogt, N. Mithulananthan
Sponsor: Swedish International Development Cooperation Agency, Sweden

Total Contracted Amount (THB): 3,285,600

AIT Support to National University (2007-2010)-Financial Management

Duration: 01 Jun 07 - 31 Dec 10
Project Investigator(s): Dietrich Schmidt-Vogt
Sponsor: Swedish International Development Cooperation Agency, Sweden
Total Contracted Amount (THB): 998,000

Development of Regional TCP project on mitigating climate change through implementation of improved agricultural practices in South Asia

Duration: 01 Feb 10 - 30 Sep 10
Project Investigator(s): Rajendra P Shrestha
Sponsor: FAO
Total Contracted Amount (THB): 822,000

International Forestry Resources and Institutions Training

Duration: 01 May 09 - 30 Dec 10
Project Investigator(s): Ganesh Shivakoti
Sponsor: Indiana University MacArthur Foundation & Ford Foundation Hanoi/Vietnam
Total Contracted Amount (THB): 586,250

Monitoring and Conserving Forest Diversity in Nam Dong District, Thua Thien Province, Vietnam

Duration: 01 Jan 06 - 31 Dec 10
Project Investigator(s): Ganesh Shivakoti (Edward L. Webb)
Sponsor: The MacArthur Foundation
Total Contracted Amount (THB): 12,800,000

MSU Study Abroad Program January 2010

Duration: 10 Jan 10 - 31 Dec 10
Project Investigator(s): Rajendra P Shrestha
Sponsor: Michigan State University
Total Contracted Amount (THB): 900,374

Roles of Natural and Restored Forests in Carbon Sequestration and Climate Change

Duration: 15 Nov 08 - 30 Oct 10
Project Investigator(s): Rajendra P Shrestha/
Dietrich Schmidt - Vogt
Sponsor: RTG
Total Contracted Amount (THB): 900,000

5.8.4 On-going Grants and Sponsored Research

Collaboration on Capacity Building of Hanoi Agricultural University and Hue University of Agriculture and Forestry in Initiating INRM and Poverty Alleviation

Duration: 01 Jul 08 - 31 Jul 12

Project Investigator(s): Ganesh P. Shivakoti

Sponsor: The Ford Foundation, Hanoi, Vietnam

Total Contracted Amount (THB): 6,536,600

Downscaling Global climate data for assessing the impact of Climate change on *Dipterocarp* species in Peninsular Thailand

Duration: 01 Jul 09 - 31 Mar 11

Project Investigator(s): Rajendra P. Shrestha

Sponsor: RTG

Total Contracted Amount (THB): 999,600

Making the Mekong Connected: Developing carbon and multidiversity assets for multifunctional landscapes in upper Mekong

Duration: 01 Mar 09 - 28 Feb 12

Project Investigator(s): Rajendra P. Shrestha

Sponsor: World Agroforestry center

Total Contracted Amount (THB): 2,187,588

The Collaborative Graduate program in Integrated Natural Resources Management between Hanoi University of Agriculture and Hue University of Agriculture and Forestry

Duration: 15 Jul 09 - 14 Jul 12

Project Investigator(s): Ganesh Shivakoti

Sponsor: Ford Foundation Hanoi

Total Contracted Amount (THB): 12,184,992

Modeling Interactions between human activities and biophysical processes in coastal ecosystem

Duration: 01 Nov 08 - 31 Mar 10

Project Investigator(s): Rajendra P. Shrestha

Sponsor: RTG

Total Contracted Amount (THB): 608,000

5.8.5 Publications

International Journal Articles with Impact factor

Affholder, F., Jourdain, D., Quang, D. D., Tuong, T. P., Morize, M. & Ricome, A. (2010). Constraints to farmers' adoption of direct-seeding mulch-based cropping systems: A farm scale modeling approach applied to the mountainous slopes of

Vietnam. *Agricultural Systems*, 103(1), 51-62.

Bastakoti R.C., Ganesh P. Shivakoti, Lebel L.. Local irrigation management institutions mediate changes driven by external policy and market pressures in Nepal and Thailand. *Environmental Management*, 3(46) 0-0, 2010.

Dietrich Schmidt-Vogt, Hardiono M., Dao T.M., Leisz S.J., Mertz O.. An assessment of trends in the extent of swidden in southeast asia. *Human Ecology*, 3(37) 0-0, 2010.

Ghimire Y.N., Ganesh P. Shivakoti, Sylvain Roger Perret. Household-level vulnerability to drought in hill agriculture of Nepal: Implications for adaptation planning. *International Journal of Sustainable Development and World Ecology*, 3(17) 0-0, 2010.

Kabir Md.E., Edward L. Webb. Household and homegarden characteristics in southwestern Bangladesh. *Agroforestry Systems*, 2(75) 0-0, 2010.

Karna B.K., Ganesh P. Shivakoti, Edward L. Webb. Resilience of community forestry under conditions of armed conflict in Nepal. *Environmental Conservation*, 2(37) 0-0, 2010.

Khumsri M., Ruddle K., Ganesh P. Shivakoti. Rights and conflicts in the management of fisheries in the Lower Songkhram River Basin, Northeast Thailand. *Environmental Management*, 4(43) 0-0, 2010.

Mahdi, Ganesh P. Shivakoti, Dietrich Schmidt-Vogt. Livelihood change and livelihood sustainability in the uplands of Lembang subwatershed, West Sumatra, Indonesia, in a changing natural resource management context. *Environmental Management*, 1(43) 0-0, 2010.

Manandhar S., Dietrich Schmidt-Vogt, Sylvain Roger Perret, Kazama F.. Adapting cropping systems to

climate change in Nepal: a cross-regional study of farmers' perception and practices. *Regional Environmental Change*, () 0-0, 2010.

Podchong S., Dietrich Schmidt-Vogt, Kiyoshi Honda. An improved approach for identifying suitable habitat of Sambar Deer (*Cervus unicolor* Kerr) using ecological niche analysis and environmental categorization: Case study at Phu-Khieo Wildlife Sanctuary, Thailand. *Ecological Modelling*, 17(220) 0-0, 2010.

Pongsai, S., D. Schmidt-Vogt, R. P. Shrestha, R. Clemente, and A. Eiumnoh. 2010. Calibration of MUSLE for Simulating Sediment Yield in Steeply Sloping Terrain: A Case Study in Khun Satan Catchment of Northern Thailand, *Canadian Journal of Soil Science*, 90(4) 585-596.

Pongsai, S., R. P. Shrestha, D. Schmidt-Vogt, R. Clemente, N.K. Tripathi, V. Trelo-Ges, and S. Paramee, 2010. GIS-based DSS for Optimal Multi-objectives Erosion Management: A case study of the Huai Talupkup Watershed, Thailand, *International Journal of Geoinformatics*, 6(3): 67-78.

Ponza S., Preeda Parkpian, Chongrak Polprasert, Rajendra Prasad Shrestha, Jugsujinda A.. Removal of trichloroethylene (TCE) contaminated soil using a two-stage anaerobic-aerobic composting technique. *Journal of Environmental Science and Health - Part A Toxic/Hazardous Substances and Environmental Engineering*, 5(45) 0-0, 2010.

Rabin Shrestha, Dietrich Schmidt-Vogt, Gnanavelrajah N.. Relating plant diversity to biomass and soil erosion in a cultivated landscape of the eastern seaboard region of Thailand. *Applied Geography*, 4(30) 0-0, 2010.

Rerkasem K., Lawrence D., Padoch C., Dietrich Schmidt-Vogt, Ziegler

A.D.. Consequences of swidden transitions for crop and fallow biodiversity in southeast asia. *Human Ecology*, 3(37) 0-0, 2010.

Shen S., R. P. Shrestha, and J. Qian, 2010. Participatory technology development for improving animal-technical service system in Gongshan County, Northwest Yunnan Province, China, *African Journal of Agricultural Research*. 5(16), pp. 2143-2152.

Shrestha R. P., Dietrich Schmidt-Vogt, Gnanavelrajah N.. Relating plant diversity to biomass and soil erosion in a cultivated landscape of the eastern seaboard region of Thailand. *Applied Geography*, 4(30) 606-617, 2010.

Singhrattana N., Mukand S. Babel, Sylvain Roger Perret. Hydroclimate variability and its statistical links to the large-scale climate indices for the Upper Chao Phraya River Basin, Thailand. *Hydrology and Earth System Sciences Discussions*, 5(6) 0-0, 2010.

Sowana, A., R.P. Shrestha, P. Parkpian, and S. Pongquan, 2010. Influence of Coastal Land Use on Soil Degradation in Pattani basin, Thailand. *Journal of Coastal Research* [online: 24 March 2010, <http://www.jconline.org/doi/abs/10.2112/JCOASTRES-D-09-00050.1>].

Ting Z., Haiyun C., Ganesh P. Shivakoti, Roland Cochard, Homchaim K.. Revisit to community forest in northeast of Thailand: changes in status and utilization. *Environment, Development and Sustainability*, () 0-0, 2010.

Udayakumara, E.P.N., R.P. Shrestha, L. Samarakoon and D. Schmidt-Vogt, 2010. Assessment, People's Perception and Socioeconomic Determinants of Soil Erosion: a Case Study of Samanalawewa Watershed, Sri Lanka, *International Journal of Sediment Research*, 25(4):1-17.

Wickramasinghe S., Oleg Shipin, Oleg Shipin, Roland Cochard, Anceno A.J., Oleg Shipin. Multi-functional pollution mitigation in a rehabilitated mangrove conservation area. *Ecological Engineering*, 5(35) 0-0, 2010.

5.8.6 Doctoral Students' Dissertation

Contribution of NTFPs [Non-Timber Forest Products] to Livelihood in Upper Humla Nepal
By Rabintra Roy
Supervisor: Dr. Dietrich Schmidt-Vogt

Determinants of Land Use Change in Prasae Watershed of Thailand: Role of Land Tenure Security
By Nareeluck Wannasai
Supervisor: Dr. Rajendra P Shrestha

Developing GIS Based Decision Support System for Soil and Water Conservation: A Case Study of Upper Nam Heang Watershed, Northern Province
By Somnuek Pongsai
Supervisors: Dr. Dietrich Schmidt-Vogt / Dr. Rajendra P. Shrestha

Enhancement of Rural Livelihoods in Thailand: An Application of Sufficiency Economy Approach in Community Economic Development
By Wanchat Suwankitti
Supervisor: Dr. Soparth Pongquan

Exploring Conditions for Sustainability of Community Forest Management in Nam Dong District, Central Vietnam
By Ngo Tri Dung
Supervisor: Dr. Edward L. Webb

Impact of Armed Conflict on Community-Based Forest Governance and Management in Nepal
By Birendra Kumar Karna
Supervisor: Prof. Ganesh P. Shivakoti

Influence of Coastal Land Use, Fisheries and Socio-Economics on Natural Resources Degradation in Patthani Bay, Thailand
By Akom Sowana
Supervisors: Dr. Rajendra P. Shrestha / Dr. Soparth Pongquan

Institutional Dynamism and Performance of Irrigation Systems: A Comparative Study Between Nepal and Thailand
By Ram Chandra Bastakoti
Supervisor: Prof. Ganesh P. Shivakoti

Remote Sensing Modeling for Estimating Methane Gas Emission from Irrigated Paddy Fields in Thailand
By Sawettachat Srisurat
Supervisor: Prof. Jayant K. Routray

5.8.7 Masters Students' Theses and Research Studies

A Comparative Assessment of Land Management Approaches in Bhutan: Case Studies from Dagana and Chukha Districts
By Yeshey
Supervisors: Dr. Dietrich Schmidt-Vogt / Dr. Rajendra P Shrestha

An Assessment of Foreign Land Acquisition Processes in Four GMS Countries: Case Studies of Impacts on Livelihoods in Cambodia and Lao PDR
By Merina Lohani Sitoula
Supervisors: Dr. Sylvain Roger Perret / Dr. Rajendra P Shrestha

An Investigation of the Household Level Vulnerability to Sea-Level Rise (SLR) in the Coastal Areas of Bangladesh: Risks, Perceptions and Adaptation
By Arifeen Akter
Supervisor: Dr. Roland Cochard

Assessing the Vulnerability of People's Livelihood in Far-Western Nepal: Implications on Adaptation to Climate Change
By Binaya Pasakhala
Supervisor: Dr. Rajendra P Shrestha

Assessment of the Impact of Sand-dust Storm on Oasis Agriculture in Arid Area: Case Study of Bugur County, Northwest China
By Aishajiang Aili
Supervisor: Dr. Rajendra P Shrestha

Carbon Stock in Biomass and Soil of Private Mangrove Plantations (Rhizophore apiculata) in Yisan Sub-district, Amphawa District, Samut Songkram Province
By Kanokwan Homchaim

Supervisor: Dr. Roland Cochard

Community Based Fisheries Management: A Case Study in Tam Giang - Cau Hai Lagoon, Thua Thien Hue Province, Vietnam

By Nguyen Hoai Son
Supervisor: Dr. Rajendra P Shrestha

Conflicts in Forest Resources Usage and Mangement: A Case Study of Phong Dien Nature Reserve in Thua Thien Hue Province, Vietnam

By Nguyen The Van
Supervisor: Prof. Ganesh P. Shivakoti

Economic Valuation of Protected Areas: Application of CVM and TCM Approaches in Khao Yai National Park, Thailand

By Rungrote Yarnsiri
Supervisor: Dr. Sylvain Roger Perret

Effectiveness of Beach Management Units in Managing Fisheries Resource and

Improving Livelihood of the Local Communities in Mafia District, Tanzania

By King'omela Hassan Geni
Supervisor: Dr. Roland Cochard

Factors Affecting Attitude of Shrimp Farmers on Voluntary Environmental Management in Coastal Samut Sakhon Province, Thailand

By Ratchkrit Sangsukdee
Supervisor: Dr. Rajendra P Shrestha

Impacts of Multi Stakeholder Forest Projects on the Livelihood of Ethnic People in Doi Mae Salong, Chiang Rai, Thailand

By Sona Shakya
Supervisor: Dr. Dietrich Schmidt-Vogt

Mapping Landslide Hazard and Developing Land Capability-Based Management Practice in Central Java, Indonesia

By Syamsul Bachri
Supervisor: Dr. Rajendra P Shrestha

Nomads to Migrants: Changing Livelihoods and Grazing Patterns of Bayan Onjuul Soum (Tuv Aimag) in Mongolia

By Sergelen Seki Rendorj
Supervisors: Dr. Roland Cochard / Dr. Dietrich Schmidt-Vogt

Socio-Technical Assessment of Payment for Environmental Services (PES) Scheme: A Case Study of Kulekhani Watershed, Nepal

By Karuna Adhikaree
Supervisor: Dr. Sylvain Roger Perret

Research Study: Local People's Participation in Community Forest Management: A Case Study of Con Cuong District, Nghe An, Vietnam

By Nguyen Thi Huyen
Supervisor: Dr. Roland Cochard

Development of regional TCP project on mitigating climate change through implementation of improved agricultural practices in south Asia



Land degradation and sustainable land management (SLM) are an important issue in Asian developing countries, such as Bangladesh, Bhutan, Nepal, Sri Lanka. The project on "Development of regional TCP project on mitigating climate change through implementation of improved agricultural practices in south Asia" brought together abovementioned partner countries for a brainstorming workshop to develop further activities in implementing improved agricultural practices for Sustainable Land Management in the participating countries towards increased adaptation of the agriculture sector to climate change

5.9: SERD – PULP AND PAPER TECHNOLOGY FIELD OF STUDY



5.9.1 Introduction

This field of study strives for finding basic solutions for the immediate technical problems facing the local pulp and paper industry. Research activities in PPT are focused on optimising pulping, bleaching and papermaking processes with emphasis on the reduction of their negative impact on environment. The quality of the product is also emphasized to maintain competitive edge of local pulp and paper industry in the global market. Modification of existing processes to suit local raw material is another challenging area of research. The field of study is also launching a new program with focus on biorefining. Biorefining is a new trend of pulp and paper industry. The industry along with production of pulp pioneers production of transportation fuel, chemicals and medicine from the same raw material (i.e. lignocelluloses).

5.9.2 Research Facilities and Laboratories

The Pulp and Paper Laboratory was established to provide the need for research and high level education for this specific field. The laboratory is equipped with all basic facilities for teaching and research purposes in the field of pulp and

paper technology. Several sophisticated equipment have been constantly furnished to extend the services for advance research and special studies likewise. The facilities are provided for activities in pulping paper testing, printing and coating, as well as for wood component analysis. The equipment is standardized according to ISO, TAPPI, and Scandinavian Standards. The programmable six-vessel autoclave digester makes cooking study in research level possible in the most convenient setting. Other major equipment in Pulp and Paper Laboratory include the single batch digester, bleaching reactor, sheet formers, fiber length analyzer, formation tester, deinking flotation cell, and spectrophotometer with ERIC option. In addition to provide assistance and research facilities needs for students, faculty, the laboratory also provides professional services for pulp and paper industry internationally. Among its major equipment include a 6-bomb autoclaved digester, CRS Engineering; Bleaching reactor; Buchi extraction system; GC; Zeta potential tester; Charge density tester; PFI mill; Valley beater; Escher Wyss refiner; AMC Medium Consistency disintegrator; Voith Sulzer Deinking unit; Fiber length analyzer FS-200, Kajaani; L&W Fiber Tester; Handsheet former set with white water recirculation option; Fiber line ESpectrophotometer with ERIC

option; Ambertec beta formation tester and Calender.

5.9.3 Faculty and Research Staff

Full-time Faculty

SAID IRANDOUST, MSc, PhD, Chalmers University of Technology, Sweden

Professor [*catalytical gas-fluid processes with a focus on reaction kinetics, mass transport, flow calculations, reactor modeling and reactor design*]

MOUSA M NAZHAD, BSc, Univ of Concordia, Montreal, Canada; MSc, Univ of Concordia, Montreal; PhD, Univ of British Columbia, Vancouver, Canada.

Associate Professor [*Recycled fiber, Paper and Paperboard quality, Nanoparticles in papermaking, Specialty papers, Pulp processing and Biorefining*]

Visiting Faculty

SHASHANK BHARTI, BSc, Vikram Univ, India; Post Graduate Diploma, Indian Inst of Tech, India; PhD, Technical Univ of Lodz, Poland

Visiting Faculty

ESA MATTI JUHANI VIJAKAINEN, MSc. in Chem. Eng. (HUT), Tech. Lic. (HUT), Helsinki University of Technology, Finland.

Visiting Faculty [*Fiber Processing: Mechanical pulping and Recycled fiber technology; Expert in industrial effluent treatment and Environment technology*]

AHMAD MIRSHOKRAEI, BSc, Univ of Tehran, Iran; MSc, Univ of TEHRAN, IRAN; PhD, Univ of McGill, Montreal, Canada.

Professor [*Pulping, bleaching, lignin structure*]

Adjunct Faculty

HAKAN KOLMODIN, MSc. in Chemical Engineering, Ph.D. Engineering Chemistry, Chalmers University of Technology, Sweden.

Adjunct Faculty [*Pulp and Paper Mill, cooking chemistry, bleaching chemistry, paper chemistry, printing technology/printability*]

Visiting Lecturers

ELIAS ANTERO RETULAINEN, MSc., D.Tech. in Paper Technology, Helsinki University of Technology, Finland.

Visiting Lecturer [*Fiber and Paper Science*].

EWALD BEIVI, Graduate in Sheet-fed offset printing; in Publication rotogravure printing; Eledg.Dipl. in Printing Production Management & Technology, Betriebsfachmann Druck, St. Gallen, Switzerland.

Visiting Lecturer [*Covering printing technology*]

ESA KALEVI LEHTINEN, M.Sc. (Tech.) in Wood Chemistry and Pulping Technology, Lic.Sc. (Tech.) in Paper Technology and Chemistry of Forest Products, Helsinki University of Technology, Finland.

Visiting Faculty [*Pigment coating technology of paper, Paper technology in general*]

RAIMO O MALINEN, MSc, LicTech, DTech, Helsinki Univ. of Tech., Finland.

Associate Professor [*Wood and Fibre Chemistry in general; Pulping Technology; Environmental Technology; Project Management*]

Research Staff

Ms. Nareerat Nitisoravut, Senior Laboratory Supervisor

Ms. Lalita Joshi, Laboratory Supervisor

Technician and Laboratory

Mr. Manoch Suansiri, Laboratory Technician II

Mr. Suchart Junteing, Laboratory Technician II

Mr. Kanong Malaithong, Laboratory Technician I

Administrative Staff

Ms. Suwannee Tilapornputt, Secretary II

5.9.4 Publications

International Journal Articles with Impact factor

Fatehi P., Arabshahi S., Ziaee Z., Raimo Malinen, Ni Y.. Simulating the impact of kraft pulping and bleaching parameters on eucalyptus camaldulensis pulp properties using matlab. Canadian Journal of Chemical Engineering, 3(88) 0-0, 2010.

Fatehi P., Raimo Malinen, Ni Y.. Bleachability of pulps produced from

different kraft pulping methods: A laboratory study. Pulp and Paper Canada, 8(110) 0-0, 2010.

Fatehi P., Raimo Malinen, Ni Y.. Removal of hexenuronic acid from Eucalyptus kraft pulps during chlorine dioxide- And ozonebased ecf bleaching sequences. Appita Journal, 3(62) 0-0, 2010.

Khosravani A., Latibari A.J., Mirshokraei S.A., Rahmaninia M., Mousa M. Nazhad. Studying the effect of cationic starch- anionic nanosilica system on retention and drainage. BioResources, 2(5) 0-0, 2010.

Lalita Joshi, Raimo Malinen, Holmbom B.. Deresination of Acacia mangium pulp - Role of cooking and washing additives and removal of fines. Appita Journal, 3(62) 0-0, 2010.

Lin T., Yin X., Mousa M. Nazhad, Esa Lehtinen. Increased filler content by co-flocculation of chemical pulp fines and filler. Appita Journal, 4(63) 0-0, 2010.

Luangsaard N., Raimo Malinen, Esa Viljakainen, Pisuttipiched S., Preeda Parkpian. Effect of harvesting age on the amount and composition of wood extractives from Eucalyptus camaldulensis. Paperi ja Puu/Paper and Timber, 2(92) 0-0, 2010.

Xiaoyong Chen, Mousa M. Nazhad. How is frayed fiber generated during refining process? (identification of frayed fiber under high resolution microscope). Journal of Engineered Fibers and Fabrics, 3(5) 0-0, 2010.

Conference Publication

Srikanth N., Mousa M. Nazhad. Coating color rheology and coated paper properties using nano-biopolymer as binder. Appita Annual Conference, () 0-0, 2010.

5.9.5 Doctoral Students' Dissertations

Characterization and Evaluation of Papermaking Qualities in Selected Thai Bamboo

By Nareerat Nitisoravut
Supervisors: Assoc. Prof. Erik L.J. Bohez/Dr. Esa Viljakainen

5.9.6 Masters Students' Theses and Projects

A Comparative Study of Three Fast Growing Hardwood Kraft Pulps as Material in Uncoated Fine Paper

By Xu Wen Xia
Supervisor: Dr. Esa Viljakainen

Bleaching Comparison on Acacia Kraft Pulp Produced from Continuous and Batch Cooking System

By Itsna Lathifah Lasmarety
Supervisor: Dr. Esa Viljakainen

Developing Water Resistance Paper through Poly (ε-caprolactone) and Soy Protein Isolation

By Nattinee Bumbudsanpharoke
Supervisor: Dr. Mousa M. Nazhad

Effect of Paper Broke and Filtrate Water on Paper Properties

By Damrongjet Santijamroenkit
Supervisor: Dr. Mousa M. Nazhad

Effect on Chip Thickness on Kraft Cooking and Bleachability of Acacia Crasscarpa

By Radar Herri Dalimunthe
Supervisor: Dr. Esa Viljakainen

Effects of Process and Wet End Variables on Alum-Cationic Rosin Sizing & Comparisons with Pac-Cationic Rosin and Akd Sizing

By Chuong Ma Tien
Supervisor: Dr. Mousa M. Nazhad

Evaluation of Oxygen Delignification Process on Removing Lipophilic Extractive Acacia Mangium and Acacia Crasscarpa

By Ari Aji Sanyoto
Supervisor: Dr. Esa Viljakainen

Non-Chemical Recycling of MOW by Fractionation

By Tunchira Bunyaphiphat
Supervisor: Dr. Mousa M. Nazhad

The Role of OCC Long Fiber Fractionation on Testliner Strength

By Luong Chi Hieu

Supervisor: Dr. Mousa M. Nazhad

The Role of Sulphuric Acid Addition on Hot Chlorine Dioxide Bleaching of Unbleached Acacia Kraft Pulp

By Azka Aman
Supervisor: Dr. Esa Viljakainen

Project: Linting Problem of Newsprint Due to Filler Content: A Theoretical Approach

By Marin Malai
Supervisor: Dr. Esa Viljakainen

Project: Using Hybrid Tulip as Pulpwood for Kraft Pulping

By Yanyan Han
Supervisor: Dr. Esa Viljakainen

5.10: SERD – REGIONAL AND RURAL DEVELOPMENT PLANNING FIELD OF STUDY



Products produced by local rural community in Northeastern Thailand

5.10.1 Introduction

This field of study focuses on rural poverty, improvement of the quality of life, and social and economic development of rural areas. Practice oriented rural regional planning is carried out regularly at district and subdistrict levels following a participatory and integrated approach, and attention is paid to management of development Institutions, infrastructure and physical resources. Sectoral and spatial planning is equally emphasized along with the management of rural development programs and local development projects to strengthen rural communities for sustainable development.

5.10.2 Faculty and Research Staff

Full-time Faculty

GOPAL B THAPA, BSc, Tribhuvan Univ, Nepal; MSc, DTechSc, AIT, Thailand.

Professor (*Natural Resources Management; Sustainable*

Agricultural Development and Planning; Watershed Management)

JAYANT K ROUSTRAY, BSc (Hons), MSc, PhD, Utkal Univ; MRP, Indian Inst of Tech, India.

Professor (*Regional and Rural Development Planning, Rural-Urban Relations, Regional Planning Methods and Techniques, Disaster Risk Reduction and Management, Climate Change Induced Adaptation, and GIS Applications*)

SOPARTH PONGQUAN, BSc, Chiang Mai Univ; MSc, AIT, Thailand; DSc, Univ of Wageningen, The Netherlands.

Associate Professor (*Capacity Building; Community Development and Monitoring and Evaluation of Development Projects; Decentralized Local Government; People's and Community Participation; Rural Development*)

MOKBUL MORSHED AHMAD, BSc, MSc, Dhaka Univ, Bangladesh; MSc, AIT, Thailand; PhD, Univ of Durham, UK.

Associate Professor (*Economic geography; regional and rural development planning; community development; Non-Governmental Organizations (NGOs); civil society; globalization etc*)

Professional Staff

VITON NIL-UBOL, MSc, AIT, Thailand

Field Lab Supervisor, Regional and Rural Development Planning

5.10.3 Grants and Sponsored Research Completed in 2010

Online Pilot programme on Sustainable development practices in public policy

Duration: 01 Jun 09 - 30 Jun 10

Project Investigator(s): Mokbul Morshed Ahmad

Sponsor: TERI University, New Delhi, India

Total Contracted Amount (THB): 289,000

Understanding the next Agricultural Transition in Asia

Duration: 01 Nov 09 - 30 Dec 10
 Project Investigator(s): Gopal B. Thapa
 Sponsor: Rockefeller Foundation
 Total Contracted Amount (THB): 2,768,194

4.10.4 Publications

International Journal Articles with Impact factor

Alam, J. and Ahmad, M. M. (2010). "Analysing the lacunae in planning and implementation: spatial development of Dhaka city and its impacts upon the built environment". *International Journal of Urban Sustainable Development*. Vol. 2, Nos. 1–2, pp. 85–106.

Gopal Bahadur Thapa, Rattanasuteerakul K.. Adoption and extent of organic vegetable farming in Mahasarakham province, Thailand. *Applied Geography*, () 0-0, 2010.

Krongkant P., Mokbul Morshed Ahmad. Typhoon risk perceptions and evacuation decisions of older persons: A case study of a rural community in southern Thailand. *International Journal of Emergency Management*, 2(7) 0-0, 2010.

Memon J.A., Gopal Bahadur Thapa. The Indus Irrigation System Natural Resources and Community Occupational Quality in the Delta Region of Pakistan. *Environmental Management*, () 0-0, 2010.
 Memon, J.A. and Thapa, G.B (2010), "Impacts of upstream irrigation development on deltaic landscape, resources and livelihood –A Case of Indus Delta in Sindh Province, Pakistan", *International Journal of Environment and Rural Development*, Vol. 1-2, pp. 67-72, IAS/UNU

Morais N., Mokbul Morshed Ahmad. Sustaining livelihoods in complex emergencies: Experiences of Sri

Lanka. *Development in Practice*, 1(20) 0-0, 2010.

Nepal R., Gopal Bahadur Thapa. Determinants of agricultural commercialization and mechanization in the hinterland of a city in Nepal. *Applied Geography*, 3(29) 0-0, 2010.

Paul S.K., Jayant K Routray. Flood proneness and coping strategies: The experiences of two villages in Bangladesh. *Disasters*, 2(34) 489-580, 2010.

Paul S.K., Jayant Kumar Routray. Household response to cyclone and induced surge in coastal Bangladesh: coping strategies and explanatory variables. *Natural Hazards*, () 0-0, 2010.

Rattanasuteerakul, K., Thapa, G.B. (2010), "Towards Organic Vegetable Farming in Thailand", *Journal of Sustainable Agriculture*, Vol. 34, pp. 57-79, Taylor & Francis.

Saroar M., Jayant Kumar Routray. Adaptation in situ or retreat? A multivariate approach to explore the factors that guide the peoples' preference against the impacts of sea level rise in coastal Bangladesh. *Local Environment*, 7(15) 636-686, 2010.

Saroar M., and Jayant K. Routray, In situ adaptation against sea level rise (SLR) in Bangladesh: does awareness matter? *Climate Change Strategies and Management*, 2 (3) pp. 321-345, 2010.

Sawettachat. S, Jayant K. Routray, P. Preeda and Nitin K. Tripathi, Remote Sensing Modeling for Estimating Methane Gas Emission from Irrigated Paddy Fields in Thailand, *International Journal of Applied Environmental Sciences*, 5(6) 813–830, 2010.

Suwankitti, Wanchat and Soparth Pongquan. Sufficiency Community Economic Development System: A

Pathway to Sustainable Community Development in Thailand. *Asian Social Science*, Vol. 6, No. 7, pp. 91-96, 2010.

Thapa, G.B., Viswanathan, P.K., Routray, J.K. and Ahmad, M.M. (2010), "Understanding the next agricultural transition in Asia: A critical review of major facets and future challenges", *Millenial Asia: An International Journal of Asian Studies*, Vol. 1, No.2, pp. 215-239.

Ullah, Md. Anwar and Soparth Pongquan. Financial Resources Mobilization Performance of Rural Local Government: Case Study of Three Union Parishad in Bangladesh. *Asian Social Science*, Vol. 6, No. 11, pp. 95-115, 2010.

Conference Proceedings

Jayant K. Routray, Perspectives and New Directions for Regional Development Planning Under Changing Scenarios, International Conference on Environment, Resource and Regional Development, 8-9 March 2010, Department of Geography, The University of Burdwan, Burdwan, West Bengal, India.

Newspaper Articles

Jayant K. Routray (2010), Keeping the promise alive to end poverty, *The Nations*, Bangkok, Thailand 14 October 2010 (Prepared for October 17 as the International Day for the Eradication of Poverty).

Books and Monographs

Ainuddin, Syed and Jayant Kumar Routray, *Earthquake Risks in Baluchistan: Community Preparedness and Emergency Management Issues*, Verlag: Lambert Academic Publishing AG & Co. KG, Koln, Deutschland, 2010, ISBN: 978-3-8383-8659-1.

Ashraf, Muhammad and Jayant K. Routray, *A Social Well-being Assessment in Balochistan, Pakistan*,

Verlag: Lambert Academic Publishing AG & Co. KG, Koln, Deutschland, 2010, ISBN: 978-3-8383-8247-0.

Shabnam, Nourin, J. K. Routray and Md. Habibur Rahman, Rural-Urban Disparity in Bangladesh (A Socio-economic Appraisal), Verlag: VDM Verlag Dr. Muller Aktiengesellschaft & Co. KG, Koln, Deutschland, 2010, ISBN: 978-3-639-24028-3.

Thapa, G.B., Viswanathan, P.K., Routray, J.K. and Ahmad, M.M. (eds.) (2010), *Agricultural Transition in Asia: Trajectories and Challenges*, Bangkok: Asian Institute of Technology, ISBN 978-974-8257-79-2.

Ullah, Md. Anwar and Soparth Pongquan. Financial Resources Mobilization Performance of Rural Local Government: Case Study of Three Union Parishad in Bangladesh. Asian Social Science, Vol. 6, No. 11, pp. 95-115, 2010.

Book Chapter

Viswanathan, P.K., Thapa, G.B., Routray, J.K. and Ahmad, M.M. (2010), Challenges facing Asian smallholder agriculture: A synthesis of five country studies. In G.B. Thapa, P.K. Viswanathan, J.K. Routray and M.M. Ahmad (eds.), *Agricultural Transition in Asia: Trajectories and Challenges*, pp. 183-216, Bangkok: Asian Institute of Technology, ISBN 978-974-8257-79-2.

4.10.5 Doctoral Students' Dissertation

Adaptation to Vulnerability of Climate Change Induced Sea Level Rise in Coastal Bangladesh

By Md. Mustafa Saroar
Supervisor: Prof. Jayant Kumar Routray

Community Preparedness and Evacuation Decision in Typhoon Emergency: A Case Study in Rural Southern Thailand

By Parichatt Krongkant
Supervisor: Dr. Mokbul Morshed Ahmad

Enhancement of Rural Livelihoods in Thailand: An Application of Sufficiency Economy Approach in Community Economic Development

By Wanchat Suwankitti
Supervisor: Dr. Soparth Pongquan

Livelihood Security of Cyclone-Prone Coastal Communities in Bangladesh: A Comparative Study

By Shitangshu Kumar Paul
Supervisor: Prof. Jayant Kumar Routray

Microfinance and the Rural Poor: Strategy of Bank for Agriculture and Agricultural Cooperatives (BAAC) in Thailand

By SuchayaVaramit
Supervisor: Dr. Soparth Pongquan

Remote sensing modeling for estimating methane gas emission from irrigated paddy fields in Thailand

By Sawettachat Srisurat
Supervisor: Prof. Jayant Kumar Routray

Sustainable Agricultural Development Policies and Farmers' Practices in NakhonPathom Province, Thailand

By Sukallaya Kasem
Supervisor: Prof. Gopal Bahadur Thapa

4.10.6 Masters Students' Theses and Research Studies

Community Based Rural Road Management in Eastern Nepal

By Rekha Shreesh
Supervisor: Prof. Gopal Bahadur Thapa

Development of Small and Medium Enterprises in Post Conflict Afghanistan

By Sabawoon Ahmadzai
Supervisor: Prof. Gopal Bahadur Thapa

Economic and Social Empowerment of Home-Based Women Workers Towards the Promotion of Gender Equality: An Examination Through the OTOP Project in Thailand

By PassaweeTapasanan
Supervisor: Dr. Mokbul Morshed Ahmad

Economic Empowerment of Khmer Women Workers at Home and Outside in Mekong Delta, Vietnam

By Danh Qui
Supervisor: Dr. Mokbul Morshed Ahmad

Governance of Decentralized Commune Development Planning in Cambodia: Case Studies of Commune Councils in Battambang Province

By Young Sokphea
Supervisor: Dr. Soparth Pongquan

People's Participation in Community Radio in Thailand: A Case Study of WatDok Chan Community Radio in Surin Province

By NichakanYuenyao
Supervisor: Dr. Soparth Pongquan

People's Participation in Conservation: A Case Study in Phluuang Wildlife Sanctuary Loei Province, Thailand

By AdisornSunthararuk
Supervisor: Dr. Soparth Pongquan

Poverty Alleviation Through NGO Interventions in Rural Balochistan, Pakistan: A Case Study of Mastung District

By Mumtaz Ali Baloch
Supervisor: Dr. Mokbul Morshed Ahmad

The Effect of Agricultural Micro-Credit on Farmers' Socio-Economic Conditions in AnGiang, Vietnam

By Trang Thi My Duyen
Supervisor: Prof. Gopal Bahadur Thapa

Research Study: Inter-District Assessment of Social Wellbeing of the People's of Balochistan

By Muhammad Ashraf
Supervisor: Prof. Jayant Kumar Routray

Research Study: Regional Variation in the Socio-Economic Development of Pakistan: An Inter-District Multivariate Analysis

By Sohail Akram
Supervisor: Prof. Jayant Kumar Routray

Research Study: Technical Efficiency of Horticulture Farms in Balochistan, Pakistan: A Stochastic Production Frontier Analysis

By Ghulam Murtaza
Supervisor: Prof. Gopal Bahadur Thapa

5.11: SERD – URBAN ENVIRONMENTAL MANAGEMENT FIELD OF STUDY



5.11.1 Introduction

Urban Environmental Management (UEM) is an area of academic discourse and professional practice in which urban planning and urban management issues are studied and practiced from an environmental management perspective.

As an academic field, UEM provides opportunities of graduate level education and research at master (M.Sc.) and doctoral (PhD) level. It also provides certificate and diploma programs, as well as post-doctoral research opportunities. It draws on and integrates theories and perspectives in established disciplines of urban planning, urban and regional development, urban economics, sustainable development, and urban policy and management studies into a distinctive framework of problems, issues and questions concerning the urban environment. It enables students to identify problems; apply appropriate analytic methodologies; design, plan and implement programs and projects; and monitor impacts and challenges within the context of sustainable development in developing societies.

The Field of Study prepares students for professional careers in the public and private sectors as well as international development agencies and civil society

organizations engaged in urban development and environmental management.

5.11.2 Research Facilities and Laboratories

In this Field of Study, any researcher gets modern computer lab and other facilities for communication. There is also a workshop room for students which can accommodate about 24 students in four clusters at a time. The workshop room also has audio-visual facilities for presentation. A new Regional Urban Resource Center (R-URC) has been established for compiling and disseminating knowledge related to urban development and environmental management issues.

5.11.3 Faculty and Research Staff

Full-time Faculty

EDSEL SAJOR, BSc, University of the Philippines; MA, PhD, ISS, The Hague, The Netherlands.

Associate Professor (Conflict Management; Governance; Land Development in Peri-Urban; Policy Process and Scientific Discourse; Politics of

Environmental Policy; State-Society Relations in UEM; Urban Land Management)

L. A .S. RANJITH PERERA, BSc, MSc, University of Moratuwa, Sri Lanka; MSc, PhD, AIT, Thailand.

Associate Professor (Urban Architecture and Environmental Design; Urban Planning and Housing; Urban Environmental Management, Results-based Project Management and Evaluation)

VILAS NITIVATTANANON, BEng, Chulalongkorn Univ; MA, Thammasat University; MEng, AIT, Thailand; PhD, University of Pittsburgh, USA.

Assistant Professor (Economic Analysis; Management of Infrastructure and Services; Systems and Integrated Management; Environmental Assessment; Waste Management; Water Engineering)

Visiting Faculty

SOO-HOON PARK, BEng, MEng, Seoul National Univ, Korea; March, UCLA, California, USA; PhD, Univ of Sydney, Australia

Visiting Associate Professor (Building Information Modeling)

Adjunct Faculty

A.T.M. NURUL AMIN, PhD, University of Manitoba, Canada
Professor (*Urban Environmental Economics and Finance*)

BANASOPIT MEKVICHAI, PhD, Cornell University, USA
Associate Professor (*Urbanization and Environmental Policy*)

Research Staff

- Dr. Muhammad Abu Yusuf, SEA-UEMA Project Director
- Dr. Ariva S. Permana, Program Specialist
- Ms. Lekha Ratnayake, Senior Project Associate
- Mr. Pravakar Pradhan, Project Associate
- Ms. Farhana Khan Lima, Project Associate
- Ms. Jubaiya Jahan, Project Associate
- Ms. Patcharaporn Panwong, Project Associate
- Ms. Sheree Ann Mendoza, Project Assistant
- Ms. Concordia Pogoy, Project Assistant
- Mr. Ekarin Thongchantr, Project Technician
- Ms. Munu Pradhan, Research Associate
- Ms. Laksiri Chomchuen, Research Associate
- Ms. Le Thi Thu Huong, Research Associate
- Ms. Siwaporn Tangwanichagapong, Research Associate

Administrative Staff

- Ms. Katesaraporn Nakdee, Secretary

5.11.4 Grants and Sponsored Research Completed in 2010

2nd Training Program on Integrated Urban Planning for Sustainable Management

Duration: 15 Oct 09 - 31 Jan 10
 Project Investigator(s): L.A.S Ranjith Perera

Sponsor: AIT Center Indoneasia
 Total Contracted Amount (THB): 556,129

Environmental Management Measures (EMMs) Applied on the Range of Formal and Informal Sectors in Selected Cities

Duration: July 2009 – June 2010
 Project Investigator(s): Ranjith Perera
 Sponsor: CIDA
 Project Budget: USD 26,000

Evaluation of TIPMSE Programs as a Tool to Support Decision Making for Promoting Waste Recycling System in Thailand

Duration: Dec 08 – Nov 10
 Project Investigator(s): Dr. Vilas Nitivattananon
 Sponsor: FTI/TIPMSE
 Total Contracted Amount (THB): 2,250,000

Project Management

Duration: 13 Aug 03 - 31 Aug 10
 Project Investigator(s): Edsel Sajor
 Sponsor: The Canadian International Development Agency (CIDA)
 Total Contracted Amount (THB): 32,922,627

Rainwater Harvesting Pilot Study

Duration: Dec 08 – Mar 10
 Project Investigator(s): Dr. Vilas Nitivattananon
 Sponsor: RTG
 Total Contracted Amount (THB): 300,000

SEA-UEMA Graduate Education

Duration: 01 Apr 08 - 31 Aug 10
 Project Investigator(s): Nurul Amin, Edsel Sajor
 Sponsor: CIDA-AIT/SEA-UEMA
 Total Contracted Amount (THB): 29,818,752

SEA-UEMA Project - Learning Networks and Training

Duration: 01 Apr 08 - 31 Aug 10
 Project Investigator(s): Vilas Nitivattananon, Edsel Sajor
 Sponsor: CIDA-AIT/SEA-UEMA
 Total Contracted Amount (THB): 12,290,528

SEA-UEMA Project - Policy Advocacy

Duration: 01 Apr 08 - 31 Aug 10
 Project Investigator(s): Norwarat Coowanitwong, Edsel Sajor
 Sponsor: CIDA-AIT/SEA-UEMA
 Total Contracted Amount (THB): 7,486,400

SEA-UEMA Project -Flagship Projects

Duration: 01 Apr 08 - 31 Aug 10
 Project Investigator(s): Ranjith Perera, Edsel Sajor
 Sponsor: CIDA-AIT/SEA-UEMA
 Total Contracted Amount (THB): 24,132,672

SEA-UEMA Project -Gender

Duration: 01 Apr 08 - 31 Aug 10
 Project Investigator(s): Koyoko Kusakabe, Edsel Sajor
 Sponsor: CIDA-AIT/SEA-UEMA

Total Contracted Amount (THB): 3,972,864

SEA-UEMA Project Management

Duration: 01 Apr 08 - 31 Aug 10
 Project Investigator(s): Edsel Sajor, Nowarat Coowanitwong, Muhammad Abu Yusuf
 Sponsor: CIDA-AIT/SEA-UEMA
 Total Contracted Amount (THB): 33,541,664

Sustainable development of Urban-rural local regions and the contented domains of Water and Hydropower development in Vietnam, Lao PDR and Thailand

Duration: 01 Jan 10 - 15 Nov 10
 Project Investigator(s): Edsel Sajor
 Sponsor: Netherlands Organisation for Scientific Research
 Total Contracted Amount (THB): 951,684

5.11.5 On-going Grants and Sponsored Research

Mekong Project 4 on Water Governance, Basin development challenges of CPWF

Duration: 01 Mar 10 - 28 Feb 13
 Project Investigator(s): Edsel Sajor, Bernadette Resurreccion
 Sponsor: CGIAR Challenge Program on Water and Food (CPWF) and the Mekong Program for Water, Environment & Resilience
 Total Contracted Amount (THB): 26,400,000

Post Consumer Carton (PCC) composition and recycling study

Duration: 25 Nov 10 - 30 May 11
 Project Investigator(s): Vilas Nitivattananon
 Sponsor: Tetra Pak Company Ltd.
 Total Contracted Amount (THB): 450,000

Strategic Environmental Assessment (SEA) for spatial planning and Capacity development for sustainable Tourism in the Golden Quadrangle development area of Greater Mekong Sub region

Duration: 31 May 10 - 31 Jan 11
 Project Investigator(s): Vilas Nitivattananon
 Sponsor: ADB
 Total Contracted Amount (THB): 379,033

5.11.6 Publications

International Journal Articles with Impact factor

Arifwidodo S.D., L .A. S. Ranjith Perera. Quality of Life and Compact Development Policies in Bandung, Indonesia. Applied Research in Quality of Life, () 0-0, 2010.

Chanthy L., Vilas Nitivattananon. Is importing second-hand products a good thing? The cases of computers and tires in Cambodia. Environmental Impact Assessment Review, () 0-0, 2010.

Edsel E. Sajor, Thu N.M.. Institutional and development issues in integrated water resource management of Saigon River. Journal of Environment and Development, 3(18) 0-0, 2010.

Houng, Le Thi Thu and **Sajor, Edsel** (2010) "Privatization, democratic reforms, and micro-governance change in a transition economy: Condominium homeowner associations in Ho Chi Minh City, Vietnam" *Cities*. Volume 27, Issue 1. Pp. 20-30.

Hue, Thi Van Le and **Sajor, Edsel** (In Press) "Livelihood and environment trade-off in *Doi Moi*: Industrial water use and wastewater management in a craft village in peri-urban Hanoi" In K. Lazarus, B. Resurreccion, N. Bardenoch and N. Dao (eds) *Water Rights and Social Justice in the Mekong Region*. London: EarthScan

Kritsanaphan, Amorn and **Sajor, Edsel** (accepted for publication 18 September 2010) "Intermediaries and Informal Interactions in Decentralised Environmental Management in Peri-Urban Bangkok" *International Development Planning Review*.

Lay, C. and **Nitivattananon, V.** "Is Importing Second-hand Products a Good Thing? The Cases of Computers and Tires in Cambodia", *Environmental Impact Assessment Review* (in press).

Rammont L., A. T. M. Nurul Amin. Constraints in using economic instruments in developing countries: Some evidence from Thailand's experience in wastewater management. Habitat International, 1(34) 0-0, 2010.

Resurreccion, Bernadette and **Sajor, Edsel** (2010). 'Not a Real Worker.' Gendering Migrants in Thailand's Shrimp Farms. *International Migration Review*. Vol 48 No. 6 (Wiley Publishers).

Saengsupavanich C., Nowarat Coowanitwong, Dencho N. Batanov, Lertsuchatavanich C.. Environmental performance evaluation of an industrial port and estate: ISO14001, port state control-derived indicators. Journal of Cleaner Production, 2(17) 0-0, 2010.

Sembiring, E. and **Nitivattananon, V.** (2010). "Sustainable Solid Waste Management Toward an Inclusive Society: Integration of the Informal Sector", *Resources, Conservation & Recycling* 54 (11), pp. 759-1026.

Sujaritpong S., Vilas Nitivattananon. Factors influencing wastewater management performance: Case study of housing estates in suburban Bangkok, Thailand. Journal of Environmental Management, 1(90) 0-0, 2010.

Tran, T. T. and **Nitivattananon, V.** "Adaptation to Flood Risks in Ho Chi Minh City, Vietnam", *International Journal of Climate Change Strategies and Management* (in press).

Truong T. T., L. A. S. Ranjith Perera. Consequences of the two-price system for land in the land and housing market in Ho Chi Minh City, Vietnam. Habitat International, 35 (30-39), 2010.

Truong T. T., L. A. S. Ranjith Perera. Intermediate levels of property rights and the emerging housing market in Ho Chi Minh City, Vietnam. Land Use Policy, 28 (124-138), 2010.

Zaki S., A. T. M. Nurul Amin. Does basic services privatisation benefit the urban poor? Some evidence from water supply privatisation in Thailand. Urban Studies, 11(46) 0-0, 2010.

Refereed Books/Chapters/Monographs

Hue, Thi Van Le and Sajor, Edsel (In Press). Livelihood and environment trade-off in *Doi Moi*: Industrial water use and wastewater management in a craft village in peri-urban Hanoi, In K. Lazarus, B. Resurreccion, N. Bardenoch and N. Dao (eds) *Water Rights and Social Justice in the Mekong Region*. London: EarthScan

Nitivattananon, V. and Wiajaya, N. (2010). "Benchmarking on Environmental Infrastructure Management in Selected Cities of Southeast Asia", Monograph, 62pp.

Perera, R. & Amin, A.T.M.N. (2010). Informal to formal sector continuum: A way forward, In Perera, R. ed. Environmental Management Measures for Overcoming the Informal-Formal Dichotomy, pp.173-175

Perera, R. & Permana, A.S. (2010). "Bridging the gaps in environmental management measures applied on formal and informal transport modes: A study in Bandung Indonesia, In Perera, R. ed. Environmental Management Measures for Overcoming the Informal-Formal Dichotomy, pp.75-111

Perera, R. ed. (2010). "Environmental Management Measures for Overcoming the Informal-Formal Dichotomy", Monograph, Pp.175

Conference Papers

Ongsakul, W., **Nitivattananon, V.**, Koottatep, T., Janecek, P. and Vo, N. D. eds. (2009). "GMSARN International Journal", Vol. 4, No. 1, Published by the Greater Mekong Subregion Academic and Research Network, Bangkok: Asian Institute of Technology, pp. ??.

Perera, R. (2010). "Mechanisms to Promote Rental Housing as an Affordable Option for the Low-

income Groups in the Bangkok Metropolitan Area. “, UI-KAAS International Conference Asia in the Midst of Global Transformation, AJB Bumiputera Hall, Building F, 2nd Floor, FISIP UI Depok Campus, Universitas Indonesia, Indonesia, July 20-22, 2010

Perera, R. (2010). “Need for Community Based Environmental Management Measures in Tsunami Affected Areas in Southern Thailand: A Case Study of Phangna Province “, Building Social Capital by Community Initiatives for Sustainable Disaster Relief, Korea Press Center & Paichai Academic Support Center, Seoul, Korea 25-26 October 2010

Sajor, Edsel. Contestations over Water Quality in Thailand and Vietnam in the Context of Peri-Urban Change and Globalization. Paper presented in the Panel on Peri-Urban Transformation in Conference on "Hanoi Millennium -- City Past and Future". Hanoi International Conference Center, 12-13 October 2010. Hanoi, Vietnam.

Sajor, Edsel. Presented in International Conference on Migration, Gender and Human Security in an Era of Global Structural Change and Crisis. International Institute of Social Studies, Erasmus University Rotterdam on 1-2 July 2010.

Other Publications

Nitivattananon, V. (2010). Ed: “Experiences from Learning Networks and Training under SEA-UEMA Project”, CIDA-AIT Partnership (2003-2010), Urban Environmental Management Field of Study, Asian Institute of Technology.

Nitivattananon, V., Yusuf, M.A., Permada, A.S. and Lloyds, I. (2010). Eds: “Experiences and Lessons Learned for Future Urban Environmental Management drawn from SEA-UEMA Project Final Partners Workshop”, CIDA-AIT Partnership (2003-2010), Urban

Environmental Management Field of Study, Asian Institute of Technology.

Perera, Ranjith (2010). Ed. “Air Pollution Reduction from Open Burning of Solid Waste Residuals in a Scavenging Community in Hanoi, Vietnam”, CIDA-AIT Partnership (2003-2010), Urban Environmental Management Field of Study, Asian Institute of Technology.

Perera, Ranjith (2010). Ed. “Cleaner Technology for Reducing Air Pollution from a Glass Recycling Enterprise in Ho Chi Minh City, Vietnam”, CIDA-AIT Partnership (2003-2010), Urban Environmental Management Field of Study, Asian Institute of Technology.

Perera, Ranjith (2010). Ed. “Community-based Solid Waste Management in Bang Plee Newtown, Samut Prakarn, Thailand”, CIDA-AIT Partnership (2003-2010), Urban Environmental Management Field of Study, Asian Institute of Technology.

Perera, Ranjith (2010). Ed. “Domestic-scale Bio-sand Filter for Increasing the Accessibility of Poor People to Clean Water in Bali, Indonesia”, CIDA-AIT Partnership (2003-2010), Urban Environmental Management Field of Study, Asian Institute of Technology.

Perera, Ranjith (2010). Ed. “Establishment of a Community Water Supply System and Water Management Group in Kotalala Village, Same District, Timor Leste”, CIDA-AIT Partnership (2003-2010), Urban Environmental Management Field of Study, Asian Institute of Technology.

Perera, Ranjith (2010). Ed. “Establishment of Recyclable Waste Banks in the Schools of Ayutthaya Municipality, Thailand”, CIDA-AIT Partnership (2003-2010), Urban Environmental Management Field of Study, Asian Institute of Technology.

Perera, Ranjith (2010). Ed. “Integrated Environmental Management in a Low-income Community in Vientiane, Lao PDR”, CIDA-AIT Partnership (2003-2010), Urban Environmental Management Field of Study, Asian Institute of Technology.

Perera, Ranjith (2010). Ed. “Providing Clean Water at an Affordable price to a Suburban Community in Ho Chi Minh City, Vietnam”, CIDA-AIT Partnership (2003-2010), Urban Environmental Management Field of Study, Asian Institute of Technology.

Perera, Ranjith (2010). Ed. “Retrofitting Kitchens to Improve the Indoor Air Quality of Home-base Food Micro-enterprises in Quezon City, Philippines”, CIDA-AIT Partnership (2003-2010), Urban Environmental Management Field of Study, Asian Institute of Technology.

Perera, Ranjith (2010). Ed. “Use of Appropriate Technology for Water Quality Improvement in a Community Managed Water Supply Project in Phnom Penh, Cambodia”, CIDA-AIT Partnership (2003-2010), Urban Environmental Management Field of Study, Asian Institute of Technology.

Perera, Ranjith (2010). Ed. “Use of Social Capital as an Investment to Improve the Environmental Condition in Km 52 Town, Lao PDR”, CIDA-AIT Partnership (2003-2010), Urban Environmental Management Field of Study, Asian Institute of Technology.

Perera, Ranjith (2010). Ed. “Wastewater Management in Floating Restaurants and Households at Rangsit Canal, Pathumthani, Thailand”, CIDA-AIT Partnership (2003-2010), Urban Environmental Management Field of Study, Asian Institute of Technology.
Perera, Ranjith (2010). Ed. “Community Rainwater Harvesting System at the Amazing Gawad

Kalinga Village, Budlaan, Cebu City, Philippines”, CIDA-AIT Partnership (2003-2010), Urban Environmental Management Field of Study, Asian Institute of Technology.

5.11.7 Doctoral Students' Dissertation

Ambiguities in the Emerging Land and Housing Market in Ho Chi Minh City, Vietnam

By Truong Thien Thu
Supervisor: Dr. L. A. S. Ranjith Perera

Application of Quality of Life Concept in Urban Planning Practices: A Case Study of Bandung, Indonesia

By Sigit Dwiananto Arifwido
Supervisor: Dr. L. A. S. Ranjith Perera

Impact Assessment of Imported Second Hand Products: The Cases of Computers and Tires in Major Urban Centers of Cambodia

By Lay Chanthy
Supervisor: Dr. Vilas Nitivattananon

Integration of Economics and Social Factors into Optimization of Solid Waste Management System

By Emenda Sembiring
Supervisor: Dr. Vilas Nitivattananon

5.11.8 Masters Students' Theses

An Analysis of a Public Bus Transport Service from the Multi-Benefits Perspective: A Case Study of Ho Chi Minh City, Vietnam

By Nguyen Thi Cam Van
Supervisor: Dr. L. A. S. Ranjith Perera

An Assessment of Energy Consumption and Carbon Emissions Related to Urban Residential Density in a Developing City: A Case Study of Bandung City, Indonesia

By Nurrohman Wijaya
Supervisor: Dr. Vilas Nitivattananon

Approaches for Water Resources Policy Assessment in a Metropolitan Area: Case of Cebu City, Philippines

By Donna Belle Calijan Pongase
Supervisor: Dr. Vilas Nitivattananon

Assessment of Urban Sprawl in Yangon City, Myanmar

By Lin Thanda Latt
Supervisor: Dr. Vilas Nitivattananon

Co-benefit Approach for Mitigating Local Warming: A Case Study of Bandung Metropolitan Area, Indonesia

By Pritta Puspitasari
Supervisor: Dr. L. A. S. Ranjith Perera

Contributions of Solid Waste Management to Sustainable Cities

By Apinyaruk Wankeo
Supervisor: Dr. Vilas Nitivattananon

Effects of Land Use Changes on the Flooding Incidence in Cagayan de Oro City, Philippines

By Richie Catherine Cabug-os Supremo
Supervisor: Dr. L. A. S. Ranjith Perera

Equity and Accessibility Issues Surrounding Land Conversion Related to River-Based Tourism: The Case of Vang Vieng Town in Lao PDR

By Ounakone Xayviliya
Supervisor: Dr. Edsel E. Sajor

Factors Contributing to Environmental Management in Private Land Rented Communities in Bangkok

By Orana Chandrasiri
Supervisor: Dr. Edsel E. Sajor

Factors Contributing to the Status of a Clean and Green City: An Exploratory Study of Pekanbaru, Indonesia

By Ratna Eka Suminar
Supervisor: Dr. L. A. S. Ranjith Perera

Outcome-Based Approach to Assess the Effectiveness of Sanitation Systems Used in the Fringe Areas of Colombo City, Sri Lanka

By Kailayar Ramesh
Supervisor: Dr. L. A. S. Ranjith Perera

Partnership Relationship for Cultural Heritage Conservation Focused on the Water-Based Old Commercial District in Thailand

By Thanapat Arnmanee
Supervisor: Dr. Edsel E. Sajor

Place-Based Identity, Migration and Environmental Behavior in Baguio City, Philippines

By Sharon Feliza Ann Palma Macagba
Supervisor: Dr. Edsel E. Sajor

Problems and Strategies for Water Loss Reduction: A Study in Vientiane Capital, Lao P.D.R.

By Lamkhong Keophilavong
Supervisor: Dr. Vilas Nitivattananon

Protection and Enhancement of Surface Water Bodies to Mitigate Local Flooding: A Case Study in Hanoi Capital, Vietnam

By Pham Quoc Dung
Supervisor: Dr. L. A. S. Ranjith Perera

Public Information Tools, Socio-Economic Attributes, and Environmental Behavior Related to Plastic Carrying Bag in BMA, Thailand

By Muslim Kunopasvorakul
Supervisor: Dr. Edsel E. Sajor

Public Participation in Urban Environmental Management Practices, A Case Study in Bandung City, Indonesia

By Retno Gita Erliana
Supervisor: Dr. Edsel E. Sajor

Socioeconomic Vulnerability to Urban Flood Hazard in the Mekong Delta: The Case of Can Tho City

By Tran Thi Huong Giang
Supervisor: Dr. Vilas Nitivattananon

Stakeholder Analysis of Urban Wetland and its Implication on Planning: A Case Study of That Luang Marsh in Vientiane Capital City, Lao PDR

By Desa Phommasack
Supervisor: Dr. Edsel E. Sajor

Tenurial Security Related to Housing Condition and Traditional Neighborhood in Sultan Ground in Yogyakarta, Indonesia

By Widayarsi Her Nugrahandika
Supervisor: Dr. Edsel E. Sajor

The Effect of Land Use Change on Mobility and Parking Condition: A Case Study in Bandung City, Indonesia

By Nino Muhamad
Supervisor: Dr. L. A. S. Ranjith Perera

Urban Environmental Changes with Tourism Development: The Case of Vang Vieng District, Lao PDR

By Soullilack Khaykhamphithoune
Supervisor: Dr. Vilas Nitivattananon

Urban Resilience Assessment in the Context of Multiple Hazards: Case of Phnom Penh City, Cambodia

By Hourn Ratana
Supervisor: Dr. Vilas Nitivattana

5.12: SERD – AGRIBUSINESS MANAGEMENT PROGRAM

5.12.1 Introduction

Agriculture plays a vital role in the economic growth of many country especially developing countries like of Asia including Thailand, China, India, Vietnam, Malaysia etc. Due the growing industrialization the importance of agri-products has increased several-folds. The food and food-products import-export policies play important role in the overall development of any country and the world as a whole.

In developing countries, since last 25 years, majority of the young people educated, came from agriculture community or from the similar background. But, due to many reasons they have not been able to compete for available jobs, which demand specialized skills and knowledge. Even in their attempts to set up small entrepreneurial activities in non-farm sector they face many problems generally not encountered by such youths in urban areas. All these rural youths can now be supported for new opportunities of entrepreneurship in business activities related to Agriculture. They have the basic understanding of agriculture, which can be utilized for promotion of business enterprises revolve around agricultural activities.

Rationale

As the nature of rural economy of many developing countries of Asia-Pacific region shifts from subsistence farming to commercial food enterprises, a new breed of agribusiness professionals is needed to manage this transformation. The proposed program will cater the unique needs of agribusiness professionals, which comprise of knowledge and skills in elements of agriculture sector policy issues, technology, marketing and finance.

Agribusiness professionals are needed in several sectors, including in multinational companies involved in corporate farming, food processing, packaging and marketing, agricultural finance institutions, agricultural cooperatives, animal feed industry, biotechnology industry, fertilizer and pesticide industry, irrigation and mechanical equipment manufacturing, medicinal plants/herbs, and government-initiated rural/agricultural development schemes.

The agri-business management program builds on long standing strengths and experience in research, and internal and external postgraduate teaching in the fields of agricultural production, preservation, processing, agro- and food-industry management and marketing, and in agricultural development.

The program focuses on the potential for and contribution of the agribusiness industry in developing economies. It is aimed at enhancing small business entrepreneurship among primary producers of agri-food products, and traders and other market intermediaries in the value chain. The course is appropriate for entrepreneurs themselves and also for people working in the public sector and non-governmental organizations. Entrepreneurs and others will be enabled to take advantage of opportunities within the agri-food and related sectors, and increase the contribution of these sectors within public and national objectives.

Objectives

Specific objectives of the Masters Program in Agribusiness Management are:

1. To train students, academics, researchers and professionals, to develop skills and practices in the area of good agricultural production, appropriate value addition, systematic marketing, food-chain supply and global trade.
2. To enhance the sustainability and capability of agricultural enterprises by providing trained students with knowledge of international standards on food safety and traceability in agricultural production, local and global trade policies etc.

5.12.2 Faculty and Professional Staff

Faculty

ATHAPOL NOOMHORM [**Professor**, Food Engineering & Bioprocess Technology Field of Study]
(Starch and Cereal Technology; Postharvest Technology; Food Processing; Agro-industrial Development)

GANESH. P. SHIVAKOTI [**Professor**, Agricultural Systems & Engineering and Natural Resources Management Fields of Study]
(Agricultural Development and Policy Analysis; Resource Development; Farming Systems; Natural Resources Management)

SUDIP KUMAR RAKSHIT [**Professor**, Food Engineering & Bioprocess Technology Field of Study]
(*Food and Biosafety; Biofuels and Food Security; New Bio-based Food Products; Bioprocess Technology*)

ANIL KUMAR ANAL [**Assistant Professor**, Food Engineering & Bioprocess Technology Field of Study]
(*Agriculture and Food Biotechnology; Bionanotechnology; Functional Properties of Proteins and Polysachharides; Food Colloids and Biopolymers; Encapsulation and Targeted Delivery of Biomolecules*)

PEEYUSH SONI [Senior **Instructor and ABM Coordinator**, Agricultural Systems & Engineering Field of Study,]
(*Terramechanics; Agricultural Instrumentation; Controlled Environment Agriculture; Agricultural Systems Analysis; Analytical Techniques*)

NICHOLAS DIMMITT [**Assistant Professor**, School of Management]
(*Action Research; Business Communication; Business Ethics; Professional Development & Training; Language Policy and Language Planning*)

RIAN BEISE-ZEE [**Associate Professor**, School of Management]
(*International Marketing and Branding; Diffusion of Innovation; Customer-manufacturer Interaction in Innovation Development*)

SUNDAR VENKATESH [**Visiting Associate Professor**, School of Management]
(*Finance; Financial Accounting; Corporate Governance; Financial Restructuring; Financial Information Management*)

SAHDEV SINGH [**Adjunct Faculty**]
(*Information and Communication Technologies; Decision Tools; ERP; Quantitative Analysis; Human Resources Development in Agro-industries; SCM*)

BOONJIT TITAPIWATANAKUN [**Adjunct Faculty**]
(*Agricultural Supply Chain Management*)

Professional Staff

IMRAN AHMAD [**Laboratory Supervisor**, Food Engineering & Bioprocess Technology Field of Study]
(*Food Enterprises Productivity; Food Process Operations; Food Supply Chain*)

5.12.3 Publications

International Journal Article with Impact factor

Nalavade P.P., Vilas M. Salokhe, Tanya Niyamapa, Peeyush Soni. Performance of Free Rolling and Powered Tillage Discs. Soil and Tillage Research, 2(109) 0-0, 2010.

5.12.4 Masters Students' Theses and Research Studies

An Economic Analysis of Palm Plantation in Northeastern Thailand: A Case Study of Seka District, Nong Khai Province

By Kulthida Chalooddong
Supervisor: Prof. Ganesh P. Shivakoti

Assessment and Opportunities of Production and Marketing Trends in Biodegradable Packaging and Materials in Thailand

By Thanasri Kongsompong
Supervisor: Prof. Athapol Noomhorm

Effects of Fluctuation in Price and Demand of White Shrimp on Farmers's Economy in Pak Phanang District, Thailand

By Winai Poobangsaeng
Supervisor: Prof. Ganesh P. Shivakoti

Role of ICT in the Agriculture Sector: A Study of Progressive Farmers, Malwa Region, Punjab, India

By Sangha Amandeep Singh
Supervisor: Prof. Sudip K. Rakshit

Sustainable Community Forest Management: A Case Study of Yangtone Village, Sai Yok District, Kanchanaburi, Thailand

By Saranya Nueamee
Supervisor: Prof. Athapol Noomhorm

Research Study: Business Analysis of Buffalo Dairy Farm: A Case Study of Murrah Farm, Plaengyao District Chachoengsao Province, Thailand

By Chanerin Maneechansook
Supervisor: Dr. Peeyush Soni

Research Study: Perception of Young Educated Consumers Towards Ready-to-Drink Milk Brands in Bangkok

By Justin Arnold Finch
Supervisor: Dr. Peeyush Soni

5.13: DISASTER PREPAREDNESS, MITIGATION AND MANAGEMENT AREA OF STUDY

5.13.1 Introduction

Rapid escalation and intensity in the incidence of severe disaster events have become a huge threat to the global community. Due to rapid rate of population growth, urbanization, poverty, climate change and geographical location, most of the Asian countries have become highly susceptible to natural disasters such as flood, cyclone, drought, earthquake, landslide, extreme temperature, heavy rain, epidemics, etc. It has been felt that there is limited capacity at global, regional and national levels in terms of knowledge base, skills training, long-term planning, emergency preparedness and policy development to respond to such severe disaster events. Consequently, this has given way to a new field of study at AIT to address these issues in innovative ways.

Disaster Preparedness, Mitigation and Management (DPMM) is an interdisciplinary academic program at AIT that started in August 2008. This program is initiated by both School of Environment and Technology (SET) and School of Environment Resources and Development (SERD). It aims to disseminate interdisciplinary education and practices to manage and minimize the effects of disasters in people on the front lines of disaster response and preparedness. It provides professional education and short course training in Disaster Preparedness, Mitigation and Management.

DPMM works closely with its partners/collaborators namely, Asian Disaster Preparedness Center (ADPC), United Nations Office for the Coordination of Humanitarian Affairs (UNOCHA), Regional Office for Asia and the Pacific, Bangkok, The Regional Integrated Multi-Hazard Early Warning System for Africa and Asia (RIMES), [Télécoms Sans Frontières \(TSF\)](#) and

United Nations Environment Programme Regional Resource Center for Asia and the Pacific (UNEP.RRCAP) to enhance a much wider understanding and knowledge sharing from the international to local level.

The courses at DPMM are designed and developed by AIT Faculties and experts from partner institutions having more than a decade of experience in this particular field. The program is being successfully run with students from Bangladesh, Canada, France, India, Indonesia, Iran, Myanmar, Pakistan, Philippines, South Africa, Sudan, Thailand and Vietnam. DPMM has recruited 26 students till date. 7 students have already graduated from the program.

Details regarding DPMM program are available at <http://dpmm.ait.ac.th>

5.13.2 Faculty and Research Staff

Coordinating faculty members

School of Environment, Resources & Development (SERD)

Regional and Rural Development Planning (RRDP)

JAYANT K ROUSTRAY, B.Sc. (Hons), M.Sc., PhD, Utkal University; MRP, Indian Institute of Technology, India.

Professor [*Regional and Rural Development Planning, Rural-Urban Relations, Regional Planning Methods and Techniques, Disaster Risk Reduction and Management, Climate Change Induced Adaptation, and GIS Applications*]

School of Engineering & Technology (SET)

Structural Engineering (STE)

PENNUNG WARNITCHAI, B.Eng. (Hon), Chulalongkorn University, Thailand; D.Eng., M.Eng., University of Tokyo, Japan.

Associate Professor [*Earthquake Engineering*]

Contributing faculty members

School of Engineering & Technology (SET)

Remote Sensing and Geographic Information Systems (RS&GIS)

KIYOSHI HONDA, B.Agr., D.Eng., University of Tokyo, Japan.

Associate Professor [*Real-time Mapping and Simulation of Geological Processes*]

NITIN KUMAR TRIPATHI, B.Tech., National Institute of Technology, Warangal, India; M.Tech., IIT; PhD, IIT, Kanpur, India.

Associate Professor [*Remote Sensing and GIS for Disaster Mitigation*]

Water Engineering and Management (WEM)

MUKAND S BABEL, B.Eng., Rajasthan Agricultural University, India; M.Eng., D.Eng., AIT, Thailand.

Associate Professor [*Drought Forecasting and Management*]

ROBERTO CLEMENTE, BSAE, University of the Philippines at Los Baños; M.Eng., AIT, Thailand; PhD, McGill University, Canada.

Associate Professor [*Floods and Droughts*]

Geotechnical and Geoenvironmental Engineering (GTE)

NOPPADOL PHIEN-WEJ, B.Eng., Chulalongkorn University, Thailand; M.S., PhD, Illinois at Urbana-Champaign, USA.

Associate Professor [*Geological Hazards*]

School of Environment, Resources & Development (SERD)

Environmental Engineering and Management (EEM)

AJIT P ANNACHHATRE, B.Tech., PhD, Indian Institute of Technology, Kanpur, India.

Professor [*Health and Ecological Risk Management*]

CHETTIYAPPAN VISVANATHAN, B.Tech., IIT, Madras, India; M.Eng., AIT, Thailand; PhD, InstNatIPolytech, Toulouse, France.

Professor [*Environmental Hazards Mitigation*]

OLEG V SHIPIN, PhD, Institute of Biochemistry and Physiology of Microorganisms, Moscow, Russia.

Associate Professor [*EIA & Disaster Management*]

Aquaculture and Aquatic Resources Management

AMRIT BART, B.A., Earlham College, USA; M.A., M.S., PhD, Auburn University, USA.

Associate Professor [*Coastal Resiliency and Disaster Preparedness*]

Gender and Development Studies (GDS)

KYOKO KUSAKABE, B.A., Sophia University, Tokyo, Japan; M.Sc., PhD, AIT, Thailand.

Associate Professor [*CBDRM & Gender Issues*]

Regional and Rural Development Planning (RRDP)

MOKBUL MORSHED AHMAD, B.Sc., M.Sc., Dhaka University, Bangladesh; M.Sc., AIT, Thailand; PhD, University of Durham, UK.

Associate Professor [*NGO Management, Community and Rural Development*]

Energy

SIVANAPPAN KUMAR, B.E., University of Madras, India; M.Eng., AIT, Thailand; PhD, InstNatIPolytechnique, Toulouse, France.

Professor [*Climate Change Mitigation*]

Urban Environmental Management (UEM)

L. A .S. RANJITH PERERA, B.Sc., M.Sc., University of Moratuwa, Sri Lanka; M.Sc., PhD, AIT, Thailand.

Associate Professor [*Disaster Management in Urban Environmental Planning*]

VILAS NITIVATTANANON, B.Eng., Chulalongkorn University; M.A., Thammasat University; M.Eng., AIT, Thailand; PhD, University of Pittsburgh, USA.

Assistant Professor [*Disaster Management in Urban Infrastructure Planning*]

Adjunct Faculty

[JAYARAMAN K V POTTY](#), B.Sc., University of Kerala, India; M.Sc., Cochin University of Science and Technology, India; PhD, Indian Institute of Technology, New Delhi, India.

Chief Scientist, Regional Integrated Multi Hazard Early Warning Systems ([RIMES](#)), [*Climate Prediction and Early Warning System*]

Affiliated Faculty

AKIYUKI KAWASAKI PhD, Yokohama National University, Japan; M.S., Yokohama National University, Japan; B.S., Yokohama National University, Japan.

Visiting Faculty [*Geospatial Technologies for Multidisciplinary Disaster & Water research*]

[A R SUBBIAH](#), Regional Integrated Multi Hazard Early Warning Systems (RIMES) [*Climate Risk Management*]

ALOYSIUS REGO, Asian Disaster Preparedness Center (ADPC), [*Disaster Management System*]

BHICHIT RATTAKUL , Asian Disaster Preparedness Center (ADPC), [*Community Based Disaster Risk Management*]

[CEES VAN WESTEN](#), Faculty of Geo-Information Science and Earth Observation (ITC), [*Landslide Hazards*]

DINAND ALKEMA , Faculty of Geo-Information Science and Earth Observation (ITC), [*Flood Hazards*]

LAL SAMARAKOON, B.Sc., University of Kelaniya, Sri Lanka; M.Sc., Saga University, Japan, PhD, Ehime University, Japan.

Director, GIC [*Geospatial Technology for Disaster Management*]

MANZUL KUMAR HAZARIKA, PhD, University of Tokyo, Japan; M.Eng., Asian Institute of Technology, Bangkok, Thailand; M.Tech., Indian Institute of Technology, Kharagpur; B.Tech., J N KrishiVishwaVidyalaya (J. N. Agriculture University), India.

Associate Director [Disaster Risk Assessment, Managing Disasters and CBDRM]

SUTAT WEESAKUL, D.Eng., M.Eng., Asian Institute of Technology; B.Eng., Chulalongkorn University, Thailand.

Affiliated Faculty [Tsunami and Coastal Engineering]

5.13.3 On-going Grants and Sponsored Research

Training on Public Health and Disaster Management

Duration: 06 Dec 10 -31 Dec 11

Project Investigator(s): Jayant K Routray

Sponsor: Public Health Institute, National Ministry of Health, Sudan

Total Contracted Amount (THB): 2,419,691.09

5.13.4 Publications

Please refer to respective Field of Studies for publications

Conference Proceedings

Bormudoi A., **Hazarika M.K.**, **Samarakoon L.**, Phaengsuwan V. and Thanasack K. (2010). Potential Use of ALOS-PALSAR in **Flood Hazard Mapping**, A Case Study in Five Districts, Lao PDR. A paper presented at the *8th Annual Mekong Flood Forum* held in Vientiane, Lao PDR, 26-27 May, 2010.

Hazarika M.K., Singh S., Uddin S. and **Samarakoon S.** (2010). Present Status and Trends of **Natural Hazards in the Asia-Pacific Region**, a paper submitted to the *29th Asian Conference on Remote Sensing* to be held in Hanoi, Vietnam, 1-5 November, 2010.

Hazarika M.K., **Samarakoon L.**, Senevirathne N., Fowze J.S.M. and de Silva R. (2010). Capacity Building in Applications of Remote Sensing and GIS for **Disaster Risk**

Assessment, A paper presented at the *ISPRS Commission-VI* held at ITC Enschede, The Netherlands, 2-4 June 2010.

Rana S., Gunasekara K., **Hazarika M.K.**, **Samarakoon L.** and Siddiquee M. (2010). Application of Remote Sensing and GIS for **Cyclone Disaster Management** in Coastal Area: A Case Study at Barguna District, Bangladesh. A paper presented at the *ISPRS Commission VIII* held in Kyoto, Japan, 9-12 August, 2010.

Book Chapters

Hazarika M.K., Das D.K. and **Samarakoon L.** (2010). Integrated Information and Communication System for Disaster Management in Bangladesh, In: ICT Series – Issue No. 2: ICT for Disaster Risk Reduction, APCICT-UNESCAP.

Hazarika M.K., Singh S. and **Samarakoon S.** (2010). Disaster risk in Asia and the Pacific (Chapter-I), Protecting Development Gains - Reducing Disaster Vulnerability and Building Resilience in Asia and the Pacific, The Asia-Pacific Disaster Report, 2010, a joint publication UNESCAP and UN-ISDR.

Book

Bibhuti Bhushan Gadanayak and **Jayant K. Routray** (2010), A path to disaster resilient communities (Comparative assessment of CBDRM Programme in multi-hazard prone areas of Orissa, India), Verlag: Lambert Academic Publishing AG & Co. KG, Koln, Deutschland, ISBN: 978-3-8433-6666-3.

5.13.5 Masters Students' Theses

Application of Remote Sensing in Drought Monitoring and Impact Analysis on Rangeland Ecosystems: A Case Study in Qazvin, Iran

By Abolfazl Abesht

Supervisor: Dr. Roberto S. Clemente

Building Disaster Resilient Coastal Community in a Multi-Hazard Prone Area of Bangladesh

By Md. Rabiul Islam

Supervisor: Prof. Jayant Kumar Routray

Comparative Assessment of CBDRM Programme in the Multi-Hazard Prone Areas of Orissa, India

By Bibhuti Bhushan Gadanayak

Supervisor: Prof. Jayant Kumar Routray

Drought Risk Assessment and Management in Selected River Basins in Cagayan Valley

By Hector Ruiz Lim, Jr.

Supervisor: Dr. Roberto S. Clemente

Optimal Location-Allocation Strategy for New Fire Stations in Dhaka City Corporate Area: An Integrated Approach Using AHP and Greedy Set Cover Algorithm

By Md. Shahab Uddin

Supervisor: Dr. Pennung Warnitchai

Vulnerability and Response to Flash Flood and Landslides in Chiang Rai Province, Thailand

By Amnat Phonmart

Supervisor: Prof. Jayant Kumar Routray

5.14: GENDER, TRANSPORTATION AND DEVELOPMENT AREA OF STUDY

5.14.1 Introduction

Asia as a region has historically experienced high intra-mobility of goods and people, but in the recent years, the quantum of such mobility has increased dramatically. Various factors have contributed to this increase, including economic disparity within the region; differences in economic/ employment/ business opportunities; transportation and communication infrastructure development, education opportunities, and a wider network of migrants in major cities and industrial areas in the region.

The largest factor is the heavy investment in the construction and renovation of road networks. Road networks, which are important for regional integration within Asia, are critical for the less developed member countries, especially those in the Greater Mekong Subregion (GMS) countries. Recognizing this, bilateral and regional financial institutions supported heavily to improve the road network. The fact that people move both within and out of the region has implications not only for the well-being of migrants themselves, but also for the sending and receiving communities.

However, several questions remain. Have these roads actually contributed to poverty alleviation in the poorer regions of Asia? Or have they only increased the disparity between the rich and poor, resulting in future social tensions in the region?

The graduate course Gender, Transportation and Development (GTD) is a multi-disciplinary program that is problem-solving in nature. It focuses on specific problems of the effect of infrastructure planning and management on equitable and sustainable development for women and men.

As a multi-disciplinary program, it focuses on: **Contributing faculty members**

1. Gender and development
2. Regional development planning
3. Infrastructure planning and management, with special focus on transportation engineering and management

It covers both the physical planning based on transportation engineering, and social, community and gender analysis and planning based on social science. It envisages to develop planning and management theories and practices contextualized to Southeast Asia, especially the GMS region.

The program consists of required courses, elective courses and research (Thesis or Research Study). Required and elective courses are offered from the areas of gender and development, transportation engineering, regional development and planning, urban environmental management, and construction engineering and infrastructure management. The Area of Study has had the first batch of students in August 2008.

5.14.2 Faculty and Research Staff

Coordinating faculty members

KYOKO KUSAKABE, **Associate Professor**, Gender & Development Studies Field of Study, School of Environment, Resources & Development

SHINYA HANAOKA, **Visiting Associate Professor**, Transportation Engineering Field of Study, School of Engineering & Technology, and Associate Professor, Tokyo Institute of Technology, Japan.

School of Engineering & Technology

Transportation Engineering Field of Study

HYUNMYUNG KIM, **Assistant Professor**

KUNNAWEE KANITPONG, **Assistant Professor**

HIRONORI KATO, **Visiting Associate Professor**, Associate Professor, Department of Civil Engineering, The University of Tokyo

PICHAJ TANEERANANON, **Visiting Associate Professor**

School of Environment, Resources & Development

Gender & Development Studies Field of Study

PHILIPPE DONEYS, **Assistant Professor**

Regional & Rural Development Planning Field of Study

JAYANT KUMAR ROUSTRAY, **Professor**

MOKBUL MORSHED AHMAD, **Associate Professor**

Urban Environmental Management Field of Study

VILAS NITTIVATTANANON, **Assistant Professor**

Research staff

LADA PHADUNGKIATI, **Project Researcher**

TANARADEE KHUMYA, **Project
Researcher**

5.14.3 Masters Students' Theses

*Gender Analysis of Labor-Based Rural
Road Construction in Thuong Trung
Commune, Vietnam*

By Nguyen Khanh Toan
Supervisors: Dr. Kyoko Kusakabe / Dr. Shinya
Hanaoka

*Gender Analysis of Rural Road
Development*

By Nyan Htat Aung
Supervisor: Dr. Kyoko Kusakabe

*Gender Analysis of the Impact of National
Road No: 3 (NR3): A Case Study in Lao-
China Border, Namtha District Luang
Namtha Province, Lao PDR*

By Chanthavisith Chanthoumphone
Supervisor: Dr. Kyoko Kusakabe

*Impact of Road Improvement on Women
Small-Scale Fish Traders: Case Study of
Fish Border Trade in Svay Rieng Province,
Cambodia*

By Kunthea Keat
Supervisor: Dr. Kyoko Kusakabe

*Women Economic Opportunities After
Binh Bridge Construction, Hai Phong,
Vietnam*

By Le Thi Thanh Huyen
Supervisor: Dr. Kyoko Kusakabe

*Research Study: Assessment of Bus
Services for Women and Men in Yangon,
Myanmar*

By Zwe Zinn Linn Phyu
Supervisor: Dr. Kyoko Kusakabe

Chapter 6: SCHOOL OF MANAGEMENT

6.1 Introduction

The School of Management (SOM) prides itself for having world class academic and professional programs. SOM is offering a PHD Program, Doctor of Business Administration (DBA) Program, Full time MBA Program, Executive Masters (EMBA) and Professional Masters in Technology Management (PMTM) programs. SOM was ranked third in 2004 by Asia Inc. among the MBA programs of South East Asia and 2008 SOM was ranked as the internationally known TOP school in Thailand.

SOM was established in October 1987 to meet the growing need for managerial expertise in the Asia – Pacific region. The School strongly believes in the need for intensive development of socially responsible corporate leaders for Asia. Currently SOM provides specialization in CSR, Entrepreneurship, Strategy, Management of Technology, Public Management, Marketing, Finance and other areas. The courses at SOM are taught by highly experienced faculty from over 15 nations.

SOM currently has students from over 30 countries and various academic backgrounds enrolled in its programs. In every case study, group work and assignment the students work in groups with students from 3 or more different nations. The bonds formed by the students during their stay in SOM have proved as important as the knowledge and skills they gain. At SOM we stress on ethics and moral values as much as the need to produce managers who can drive their organizations to profitability and prosperity.

6.2 Mission

Mission

“to develop socially responsible global leaders who will enhance organizational performance for the growth and sustainable development of economies and societies in Asia”

Vision

“to become the leading creator and disseminator of Asian management knowledge, practices and values”

Positioning

“A global management school which offers knowledge that promotes deep understanding of Asian management practices

6.3 School Governance

Dean of School

BARBARA IGEL, BA, MA, Technical Univ, Berlin; PhD, Freie Univ, Berlin, Germany.

Associate Professor (High-tech Entrepreneurship; Industrial Economics; Knowledge Management; Management of Innovation)

6.4 Management Development and Research

The School of Management is involved in training and extension activities through the Management Development Programs (MDP). MDP was established as an integral part of the School of Management (SOM). It is the research, consultancy, and executive development arm of the School. It is SOM's non-degree academic activities and programs, which complement SOM's degree

programs and other related activities of SOM. It facilitates the linkage between SOM, AIT and the business community and public sector in Asia.

The objectives of MDP:

- To establish closer links between the business community/public sector and SOM through executive education programs and consulting in the areas of Management of Technology, International Business, Service Marketing and Technology, and International Public Management.
- To facilitate the development of research projects which are both of high practical value to the business community/public sector and academically rigorous.

MDP activities include:

1. Corporate relationship management
2. Executive development programs
3. Organizing executive forums, workshops, seminars, and conferences
4. Other activities contributing to SOM's objectives

6.5 Research Facilities and Laboratories

The School of Management has 5 state-of-the-art multimedia classrooms including a large amphitheater for academic use. Each classroom is equipped with a multimedia podium that consists of LCD projectors, audio cassette recorder, VHS player/ recorder, slide projectors, built-in desktop PC, laptop and wireless internet connection.

The School of Management provides the students with an extensive range of online journals and database. The students can access the journal and database to read articles from reputed international journals. The School of

Management has its own computer laboratory for instructional purposes and there is a network of over 60 computers for student's use.

Computer Lab consultants are available during office hours to assist with computer related problems. The consultants will provide help by answering general questions relating to the lab e.g., how to obtain a computer account, questions related to the PC Proficiency about software applications, email, printing etc.

6.6 Faculty and Research Staff

Full-time Faculty

RIAN BEISE-ZEE, Dipl. Ing. (Industrial Engineering), Technical University of Berlin, Dr.oec (Economics & Business), Germany

Associate Professor
(*International Marketing, Innovation Marketing, Service Marketing*)

BARBARA IGEL, BA, MA, Technical Univ, Berlin; PhD, Freie Univ, Berlin, Germany.

Associate Professor and Dean
(*High-tech Entrepreneurship; Industrial Economics; Knowledge Management; Management of Innovation*)

DO BA KHANG, MSc, Eotvos Lorand Univ, Hungary; MSc, DTechSc, AIT, Thailand.

Associate Professor
(*Management Science; Operations Management; Project Management; Service Management; Small and medium enterprises (SME) support and management*)

DONYAPRUETH KRAIRIT, BS, Thammasat Univ, Thailand; MS, Univ of Colorado at Boulder; PhD, Massachusetts Inst of Tech, Cambridge, USA.

Associate Professor
(*Technology, Policy and Management*)

SUNUNTA SIENGTHAI, BA, Chulalongkorn Univ,Thailand; MA, PhD, Univ of Illinois, USA.

Associate Professor (*Labor & Industrial Relations, HRM, Wages & Productivity*)

ARUN KUMAR GOPALASWAMY, BCom, MCom, Bangalore Univ, India; PhD, Institute of Science,India.

Visiting Associate Professor
(*Finance; Financial Accounting*)

SUNDAR VENKATESH, BSc, BL, Univ of Calcutta; PhD, Indian Inst of Management, India.

Visiting Associate Professor
(*Finance; Financial Accounting*)

YUOSRE BADIR, M.S The Swiss Federal Institute of Technology Lausanne (EPFL), M.Sc University of Putra Malaysia, Ph.D (MOT) EPFL

Assistant Professor (*Technology, International Strategic Alliance, Organization Theory and Design*)

NICHOLAS J DIMMITT, BA, MA, San Francisco State Univ; PhD, Univ of Southern California, USA.

Assistant Professor (*Business Communication, Business Ethics, Research Methods*)

JUTHATHIP JONGWANICH, BA, MA, Thammasat Univ, Thailand; PhD, The Australian National University, Australia

Assistant Professor
(*International Economics, Multinational Enterprises, Managerial Economics and Business environment*)

VATCHARAPOL SUKHOTU, BEng, Kasetsart Univ, Thailand; MEng, Univ of Houston, Texas, USA; PhD, Texas A&M Univ, College Station, Texas, USA

Assistant Professor (*Operation Management and Supply Chain Management*)

WINAI WONGSURAWAT, B.A.S (Econ & Math., Comp. Sc.) Stanford University USA PH.D (Managerial Econ and Strategy), Kellogg School of Management, Northwestern University, USA

Assistant Professor (*Strategic Management*)

SUPASITH CHONGLERTTHAM, B. Engineering, Chulalongkorn Univ, Thailand; MBA Finance, Tulane Univ, USA; PhD, Univ of Hawaii, Manoa, USA

Senior Instructor (*Corporate Finance, Derivatives, Corporate Governance, Financial Accounting*)

Visiting and Adjunct Faculty

NAZRUL ISLAM, BScEng, BUET, Bangladesh; MEng, DEng, AIT, Thailand.

Visiting Professor (*Management of Technology; Technology and Development; Technology Policy; Technology Transfer*)

FREDRIC W SWIERCZEK, BA, Temple Univ, USA; MA, PhD, Univ of Pittsburgh, Pennsylvania, USA.

Visiting Associate Professor
(*Behavioral Science; Organizational Development*)

PETER MOSER Ph.D., M. Econ., University of St. Gallen, Switzerland

Visiting Faculty (*European Integration and International Trade Policy*)

URS BUMBACHER, M.A, Ph.D (Economics & Business Admin.), Univ. of Basel, Switzerland.

Adjunct Professor (*International Business*)

ILKKA KAURANEN, MS Engg, Lic Tech, DTech, Helsinki University of Technology, Finland.

Adjunct Professor (*Development and Management in Industry*)

INDRA M PANDEY, MComm, PhD, Univ of Delhi, India.

Adjunct Professor (*Corporate Finance, Emerging Capital Markets*)

JOHN C S TANG, BS, MS, PhD, Univ of Florida, USA.

Adjunct Professor (*Engineering Economy; International Economics; International Operating Environment of Business; Managerial Economics*)

ARNE DEUSSEN, PhD, University of Geneva, Switzerland, Master (Lic.oec.HSG), University of ST.Gallen, Switzerland

Adjunct Faculty (*Management of Change*)

GERARD TOCQUER, Ph.D., University of Nice-Sophia Antipolis, France, M.A (Marketing), University of Sherbrooke, Canada, C.P.D., Cornell University, Ithaca USA

Adjunct Faculty (*Service Innovation, Service Culture and Branding*)

JARUNEE WONGLIMPIYARAT, Post Doctorate (Finance and Innovation) Boston University and Harvard University USA, Ph.D (Tech Management) University of Manchester U.K, M.Sc. (Tech and Innovation Management) University of Sussex, U.K

Adjunct Faculty (*Tech and Innovation, Technology Commercialization*)

PHASIN SUEBSUBANUNT, Ph.D. (Business Admin.), Henley Management College, Brunel (West London) University, UK MBA, School of Management, AIT, Thailand

Adjunct Faculty (*Finance, Investment*)

RAGNAR THOR GRUNDTVIG SØEGAARD, Ph.D London School of Foreign Trade, England, Master of Business Administration, University of Gothenburg, Sweden

Adjunct Faculty (*Finance*)

SOMROTE KOMOLAVANIJ, Ph.D, M.S., University of Texas, USA

Adjunct Faculty (*Business Statistics, Economy, QC, Operations Research*)

TRITOS LAOSIRIHONGTHONG, Ph.D., (Management of Technology) School of Management, AIT, Thailand

Adjunct Faculty (*Manufacturing Strategy and Supply Chain Management*)

WILLI ZIMMERMANN, Ph.D. (Political Science) University of Munich, Germany, Post-Doc. Diploma, Swiss Federal Institute of Technology Switzerland

Adjunct Faculty (*Public Sector Management, Environmental Management*)

LALIT M JOHRI, BSc(Hons), MSc, MBA, PhD, Univ of Delhi, India.

Adjunct Faculty (*International Business; International Joint Ventures; Marketing; Negotiations; Strategic Management*)

MARK NEAL, B.A (Hons.) Sociology, university of Reading, U.K, Ph.D (Mgmt), The Business School, Bournemouth University, U.K

Adjunct Faculty (*Cross-Cultural Management, Gender and Organization Leadership*)

TRUONG QUANG, MPA, National Institute of Administration, Vietnam; Ph.D (Social Sciences), Drs. (Political Science), Free Universiteit, The Netherlands.

Adjunct Faculty (*Organizational Behavior, HRM*)

LOGAN MULLER, Ph.D (Sustainability), Kennedy Western University, USA.

Adjunct Faculty (*International Business*)

RUDOLF GRUENIG, Ph.D (BA), University of Bern, Switzerland.

Adjunct Faculty (*Strategic Management*)

EVANGELOS ANGELOS AFENDRAS, B.A., M.A, Ph.D (Humanities-Linguistics) The Johns Hopkins Univ., USA.

Adjunct Faculty (*Cross-Cultural Management, Organization Behavior, Management of Change*)

ALLAN WILLIAM, B.Ed., Univ. of Tasmania; MSc., Ph.D (Organization Development) MITASH Univ., USA.

Adjunct Faculty (*Organization Behavior, Leadership & Business Performance*)

ROBERT S. KIETEL, BA, Univ. of Colorado; Ph.D, De La Salle University, The Philippines.

Adjunct Faculty (*HRM, Leadership*)

ASHISH SADH, M.B.A., A.P.S. Univ., Rewa. Ph.D (Marketing) Devi Ahilya Univ., Indore.

Adjunct Faculty (*Sales and Marketing*)

ROLAND AMOUSSOU-GUENOU, LL.B in Business Law, National Univ. of Benin. LL.M in International Business Law, Univ. of Toulouse. Ph.D. in International Law, Univ of Paris, France.

Adjunct Faculty (*Policy and Legal Issues*)

SANKA SRINIVAS SUBRAMANYAM KUMAR, B.Teach. REC, Calicut. M.B.A. Sri venkateswara Univ. Tirupati. Ph.D. (International Finance) Indian School of Mines, Dhanbad.

Adjunct Faculty (*Finance*)

SHIVANAND BASAYYA HIRREMAATH, B.Sc., M.Sc., Karnatak Univ. Ph.D. Indian Institute of Technology, powai, Bombay.

Adjunct Faculty (*Information Technology*)

JANAKIRAMAN MOORTHY, B.Sc., Univ of Annamalai, M.Sc., Univ of Tamil Nadu Agricultural, Ph.D (Fellow Prog. In Management) Indian Institute of Management, India

Adjunct Faculty (*Advanced Marketing Management, International Business*)

ASHUTOSH P. BHUPATKAR, B.Com., Univ of Pune, MMS, Univ of Mumbai, Ph.D (Management) Univ of Pune, India

Adjunct Faculty (*Management, Indigenous Management, Systems theory, Project Management, Education*)

DHRUV DEV SHARMA, B.Sc., MBA, Ph.D (MIS) Univ of Himachal Pradesh, India

Adjunct Faculty (*Entrepreneurship Development, Management*)

6.7 Grants and Sponsored Research Completed in 2010

DBA Program in HN 2007

Duration: 01 Jul 07 - 30 Jun 10
Project Investigator(s): Indra Pandey, Nicholas Dimmitt, Freidric Swirczek, Do Ba Khang, Sundar Venkatesh, Sununta Siengthai, Nazrul Islam, Illka Kauranen
Sponsor: Participants
Total Contracted Amount (THB): 12,250,000

International Executive MBA Vietnam :Hanoi

Duration: 01 Aug 08 - 31 Dec 10
Project Investigator(s): Do Ba Khang
Sponsor: Multi donors
Total Contracted Amount (THB): 21,250,008

International Executive MBA Vietnam: HCMC, DN, VT

Duration: 01 Aug 08 - 31 Dec 10
Project Investigator(s): Do Ba Khang
Sponsor: Multi-donors
Total Contracted Amount (THB): 32,075,384

Second Public Management Executive development Program

Duration: 01 Jun 10 - 30 Sep 10
Project Investigator(s): Sununta Siengthai
Sponsor: DRIRD Ministry of Interior Thailand
Total Contracted Amount (THB): 1,399,200

6.8 On-going Grants and Sponsored Research

DBA Program in Bangkok 2006

Duration: 31 Oct 06 - 31 Dec 13
Project Investigator(s): Barbara Igel
Sponsor: Participants
Total Contracted Amount (THB): 15,552,000

DBA Program in Bangkok 2007

Duration: 01 Feb 07 - 31 Jan 14
Project Investigator(s): Barbara Igel
Sponsor: Participants
Total Contracted Amount (THB): 19,440,000

DBA Program in Bangkok 2008

Duration: 01 Jan 08 - 31 Dec 14
Project Investigator(s): Barbara Igel
Sponsor: Participants
Total Contracted Amount (THB): 16,848,000

DBA Program in HCMC 2007

Duration: 01 Feb 07 - 31 Jan 14
Project Investigator(s): Barbara Igel
Sponsor: Participants
Total Contracted Amount (THB): 14,000,000

DBA Program in HCMC 2009

Duration: 20 Jan 09 - 31 Dec 12
Project Investigator(s): Barbara Igel
Sponsor: Professional managers
Total Contracted Amount (THB): 7,425,000

DBA Program in Sri Lanka 2006

Duration: 31 Oct 06 - 31 Dec 13
Project Investigator(s): Barbara Igel
Sponsor: Participants
Total Contracted Amount (THB): 11,988,000

DBA Program in Taiwan 2007

Duration: 01 Nov 07 - 31 Dec 14
Project Investigator(s): Barbara Igel
Sponsor: Participants
Total Contracted Amount (THB): 14,025,000

Executive MBA program in HRM 2009 intake

Duration: 01 Jan 09 - 31 Jan 11
Project Investigator(s): Sununta Siengthai
Sponsor: SIDA
Total Contracted Amount (THB): 14,912,000

Executive MBA BKK Program August 2009

Duration: 01 Aug 09 - 31 Jul 11
Project Investigator(s): Nicholas J Dimmitt
Sponsor: Multi donors
Total Contracted Amount (THB): 11,416,000

Executive MBA-BKK Program, May 2008

Duration: 01 May 08 - 31 Mar 11
Project Investigator(s): Nicholas J. Dimmitt, Barbara Igel
Sponsor: Professional managers/administrators of private/public sector
Total Contracted Amount (THB): 9,000,000

International Executive MBA for Vietnam for Hanoi #10.1 & 10.2

Duration: 01 Aug 09 - 31 Dec 11
Project Investigator(s): Do Ba Khang
Sponsor: Multi donors
Total Contracted Amount (THB): 14,875,005

International Executive MBA for Vietnam for Hanoi #11.1 & 10.2

Duration: 01 Aug 10 - 31 Dec 12
Project Investigator(s): Do Ba Khang
Sponsor: Multi donors
Total Contracted Amount (THB): 16,500,000

International Executive MBA for Vietnam for HCMC

#6.1HCMC#6.2DN#3VT#2
Duration: 01 Aug 09 - 31 Dec 11
Project Investigator(s): Do Ba Khang
Sponsor: Multi donors
Total Contracted Amount (THB): 46,627,384

International Executive MBA for Vietnam for HCMC 7.1

Duration: 01 Aug 10 - 31 Dec 12
Project Investigator(s): Do Ba Khang
Sponsor: Multi donors
Total Contracted Amount (THB): 15,675,125

Methodologies and tools for food consumer market research

Duration: 01 Jul 09 - 28 Feb 11
Project Investigator(s): Rian Beise Zee
Sponsor: Food and Agriculture Organization of United Nations
Total Contracted Amount (THB): 1,382,276

ProSPER.Net Business Schools Joint Project on Integration of Social Business and UN Global compact principals in Business Education

Duration: 01 Jan 10 - 31 Jan 11
Project Investigator(s): Richard Welford
Sponsor: Ministry of the Environment of Japan through UNU-IAS
Total Contracted Amount (THB): 2,810,880

Towards Effective Policies for Innovations Financing in Asia

Duration: 10 Feb 2010 - 9 Feb 2012

Project Investigator(s): Jarunee Wonglimpiyarat with Barbara Igel (Project Advisor)

Sponsor: Canada's International Development Research Centre (IDRC)/ Centre de Recherche sur le Développement International (CRDI)

Total contracted amount THB): Baht 9,765,460 (CAD 309,900)

6.9 Publications

International Journal Articles with Impact factor

Anh Truong T.L., Fredric W. Swierczek. Predicting the relationships between human resource factors and the effectiveness of a change project. *Asia Pacific Management Review*, 1(14) 0-0, 2010.

Debnath R.M., Ravi Shankar. Assessing performance of management institutions: An application of data envelopment analysis. *TQM Journal*, 1(21) 0-0, 2010.

Dey P.K., Chotchai Charoenngam, Stephen O. Ogunlana, Kajornkiat D.. Multi-party risk management helps manage cement plant construction in Thailand. *International Journal of Services, Technology and Management*, 4(11) 0-0, 2010.

G Arun Kumar. Dynamic Risk- Return relation with Human capital: A study on Indian markets. *International Journal of Emerging Markets*, 2010

G Arun Kumar. Stability of Long-run Relationship: A study on Asian emerging and developed stock markets (Japan and US). *International Journal of Emerging Markets*, 2010

Hoang, D.T., B.Igel and T. Laosirihongthong (2010): Total Quality Management (TQM) Strategy and Organizational characteristics: Evidence from Recent WTO Member, *Total Quality Management*

&Business Excellence, Vol. 21. No. 9-10, pp.931-951.

Islam, Md. Zohurul & Sununta Siengthai (2010) "Human Resource Management Practices And Firm Performance Improvement in Dhaka Export Processing Zone," *Research and Practice in Human Resource Management Journal*, Vol. 18, Issue 1, June.

Kantabutra S., John C S Tang. Efficiency Analysis of Public Universities In Thailand. *Tertiary Education and Management*, 1(16) 0-0, 2010.

Kraus S., Ilkka Kauranen. Strategic management and entrepreneurship: Friends or foes?. *International Journal of Business Science and Applied Management*, 1(4) 0-0, 2010.

Luu Trong Tuan (2010) Organisational culture, leadership and performance measurement integratedness, *International Journal of Management and Enterprise Development*, Vol. 9, No. 3, pp. 251 – 275.

Meepadung N., John C S Tang, Do Ba Khang. IT-based banking services: Evaluating operating and profit efficiency at bank branches. *Journal of High Technology Management Research*, 2(20) 0-0, 2010.

Mukhtar, Uzma and Sununta Siengthai (2010) "Determinants of Perceived Higher Education Conflict: Empirical Evidence of Employees of Pakistan Public Universities," *International Journal of Interdisciplinary Social Sciences*, Vol.5, Issue 3, pp.23-36.

Naeem M.A., Richard Welford. A comparative study of corporate social responsibility in bangladesh and pakistan. *Corporate Social Responsibility and Environmental Management*, 2(16) 0-0, 2010.

Neelakantan Ramachandran, Nithyaprakash D., Ajjan K.B., n, Manoharan D., Sivanappan Kumar. Hybrid solar cell based on blending of organic and inorganic materials- An overview. *Renewable and Sustainable Energy Reviews*, () 0-0, 2010.

Orapan Khongmalai, John C.S. Tang, Sununta Siengthai (2010) "Empirical evidence of Corporate governance in Thai state-owned enterprises", *Corporate Governance*, Vol.10, Iss.5, pp.617-534.

Raj T., Ravi Shankar, Suhaib M.. An ISM approach to analyse interaction between barriers of transition to flexible manufacturing system. *International Journal of Manufacturing Technology and Management*, 4(16) 0-0, 2010.

Ritthisoonthorn P., Kazi Mohiuddin Ahmed, Donyaprueth Krairit. Planning of efficient wireless access with IEEE 802.16 for connecting home network to the internet. *Eurasip Journal on Wireless Communications and Networking*, (2010) 0-0, 2010.

S. Iamratanakul and S. Srivannaboon (2010), "Special Section," in: D. Z. Milosevic, et al. (Eds) *Case studies in project and program management, and organizational project management*.

S. Iamratanakul, M. Sorakraikitikul, S. Siengthai, and N. J. Dimmitt (2010), *The Relationship of Perceived Human Resource Management Practices on Employees' Performance*, *International Journal of Business Strategy*, vol. 10, no. 2, pp. 44-55.

Sudsakorn T., Fredric W. Swierczek. Management competencies: A comparative study between Thailand and Hong Kong. *Journal of Management Development*, 7(28) 0-0, 2010.

- Sukirno and Sununta Siengthai (2010) "The comparison of Graded Response Model and Classical Test Theory in Human Resource Research: A Model Fitness Test," Research and Practice in Human Resource Management, Vol. 18, Issue 2, December 2010.
- Sukirno and Sununta Siengthai (2010) "Does Participative Decision Making Affect Lecturer Performance In Higher Education?" *International Journal of Educational Management*, Vol.5, Issue 6.
- Sununta Siengthai, John J. Lawler; Chris Rowley and Hiromasa Suzuki (2010) *The Multi-dimensions of Industrial Relations in the Asian Knowledge-Based Economies: An Enterprise-Based Case Book*, to be published by Chandos Publishers, Oxford, UK, ISBN No. 978-1-84334-264-9.
- Supyuenyong V., Nazrul Islam, Kulkarni U.. Influence of SME characteristics on knowledge management processes: The case study of enterprise resource planning service providers. *Journal of Enterprise Information Management*, 1-2(22) 0-0, 2010.
- Trung T.Q., Fredric W. Swierczek. Skills development in higher education in Vietnam. *Asia Pacific Business Review*, 4(15) 0-0, 2010.
- Uzma Mukhtar and Sununta Siengthai (2010) "Determinants of Perceived Higher Education Conflict: Empirical Evidence of Employees of Pakistan Public Universities," *The International Journal of Interdisciplinary Social Sciences*, Vol. 5, No3.
- Vanichchinda, A. and B. Igel (2010): *The Impact of Total Quality Management on Supply Chain Management in Thai Automotive Industry* *International Journal of Production Research*, TAYLOR & FRANCIS, (accepted for publication,
- Ref: TPRS-2010-IJPR-0056.R1,) Journal impact factor 0.774
- Veerasoontorn R., Rian Beise-Zee. International hospital outshopping: A staged model of push and pull factors. *International Journal of Pharmaceutical and Healthcare Marketing*, 3(4) 0-0, 2010.
- Winai Wongsurawat. Does grade inflation affect the credibility of grades? Evidence from US law school admissions. *Education Economics*, 4(17) 523-534, 2010.
- Wonglimpiyarat, J. (2010), Commercialisation Strategies of Technology: Lessons From Silicon Valley, *Journal of Technology Transfer*, Vol. 35(2), pp. 225-236.
- Wonglimpiyarat, J. (2010), Economic Innovation Challenges of Financial and Tax Auditing, *Journal of Economics and International Finance*, Vol. 2(12), pp. 290-298.
- Wonglimpiyarat, J. (2010), Innovation Index and the Innovative Capacity of Nations, *Futures, the Journal of Policy, Planning and Futures Studies*, Vol. 42(3), pp. 247-253.
- Wonglimpiyarat, J. (2010), Technological change of the energy innovation system: From oil-based to bio-based energy, *Applied Energy*, Vol. 87(3), pp. 749-755.
- Wonglimpiyarat, J. (2010), Venture capital management towards the leading biotechnology center of Canada, *International Journal of Technology, Policy and Management*, Vol. 10(4), pp. 360-374.
- Book/Book Chapters**
- Wonglimpiyarat, J. (2010), Towards the Sixth Kondratieff Cycle of Nano Revolution, in N. Ekekwe (Ed.), *Nanotechnology and Microelectronics: Global Diffusion, Economics and Policy*, Information
- Science Reference (IGI Global), New York, USA and London, UK, ISBN 978-1-61692-006-7. The book is an excellent achievement to reach the top spot on Tower Books? Artificial Intelligence Top 100 list (#1 on Tower Books Artificial Intelligence Top 100 Bestsellers) and received IGI Global 2010 Excellence in Technology Research 'Book of the Year' Award.
- Sununta Siengthai; John J. Lawler; Chris Rowley; Hiromasa Suzuki (2010) *The Multi-dimensions of Industrial Relations in the Asian Knowledge-Based Economies: An Enterprise-Based Case Book*, Chandos Publishers, Oxford, UK. ISBN: 978-1-843334-264-9
- Sununta Siengthai; John J. Lawler; Chris Rowley and Hiromasa Suzuki (2010) "Chapter 1: Overview of Economic Growth and Industrial Relations in Asian Knowledge-based Economies," in Siengthai; Lawler; Rowley and Suzuki (eds.) *The Multi-dimensions of Industrial Relations in the Asian Knowledge-based Economies: An Enterprise-based Case Book*, pp.1-30.
- Sununta Siengthai (2010) "Chapter 2: Industrial Relations in the Turbulent Times" in Siengthai; Lawler; Rowley and Suzuki (eds.) *The Multi-dimensions of Industrial Relations in the Asian Knowledge-based Economies: An Enterprise-based Case Book*, pp.1-30.
- Sununta Siengthai (2010) "Chapter 7: Globalization and Industrial Relations in Thailand," in Siengthai; Lawler; Rowley and Suzuki (eds.) *The Multi-Dimensions of Industrial Relations in the Asian Knowledge-based Economies: An Enterprise-based Case Book*, pp.141-172.
- Sununta Siengthai (2010) "Chapter 9: Making Industrial Relations Work in the Globalization Era: Challenges Ahead for Knowledge-based Economies," in Siengthai; Lawler; Rowley and Suzuki (eds.) *The Multi-*

Dimensions of Industrial Relations in the Asian Knowledge-based Economies: An Enterprise-based Case Book, pp.141-172.

6.10 Doctoral Students' Dissertation

Business Administration

Process of Capital Fund Allocation in Capital Intensive Firms

By Worata Kongseanitsara

Supervisor: Prof. Indra M. Pandey/ Dr. Sununta Siengthai

International Business

A Dynamic Model of International Hospital Outshopping: An Analysis of Patient Narratives

By Ruamsak Veerasoontorn

Supervisor: Dr. Rian Beise-Zee

Control Mechanisms in Successful International Joint Ventures in Vietnam

By Cao Minh Tri

Supervisor: Prof. Lalit M Johri

Operating and Profit Efficiencies of Bank Branches - An Application of DEA

By Napapan Meepadung

Supervisor: Prof. John C S Tang

Ownership, Board Structure, and Corporate Governance: Evidence from Thailand

By Parichart Rachapradit

Supervisors: Dr. Do Ba Khang / Prof. John C S Tang

The Globalization Strategies of Thai Corporations

By Sasiprapa Chairasit

Supervisors: Dr. Winai Wongsurawat / Dr. Fredric W. Swierczek

The Role of Customer Cause Affinity on the Evaluation of Corporate Social Responsibility: An Empirical Assessment of Cause Specificity of Corporate Social Responsibility (CSR)

By Sana-ur-Rehman

Supervisor: Dr. Rian Beise-Zee

International Public Management

Factors Influencing Organizational Change and Productivity Improvement in Special Industrial Zones: An Empirical Study on Dhaka Export Processing Zone (EPZ), Bangladesh

By Md. Zohurul Islam

Supervisor: Dr. Sununta Siengthai

6.11 Masters Students' Theses, Research Studies and Projects

Research Study: Feasibility Study of the Adoption of Network Expansion Strategies by Mobile Service Providers in North East India: A Case of Aircel Limited

By Rajkumar Sarma

Supervisor: Dr. Winai Wongsurawat

Research Study: Alliances in Oil and Gas Industry Trends and Strategic Logics in Asia

By Knaporn Chongdomliuk

Supervisor: Dr. Sundar Venkatesh

Research Study: A Study of Foreign Exchange Exposures and Their Impact on Stock Returns: Evidence from Thailand

By Hariom Ghimire

Supervisor: Dr. Sundar Venkatesh

Research Study: Can We Turn Off the Bubble Machine? A Certain Application of Economic Cycles Theories to Financial Bubbles

By Cosme Julien

Supervisor: Dr. Yuosre F. Badir

Research Study: Core Competencies of Micro Businesses as Sources of Competitive Advantage: An Exploratory Study on Street Food Vending

By Eijaz Ahmed Khan

Supervisor: Dr. Rian Beise-Zee

Research Study: Degree of Family Ownership and Firm Performance: A Study of a Listed Companies in Thailand

By Pongthep Vichaikul

Supervisor: Dr. Sundar Venkatesh

Research study: Efficient Market Hypothesis: An Evidence from the Karachi Stock Exchange (KSE)

By Qurat-Ul-Ain

Supervisor: Dr. Sundar Venkatesh

Research Study: Financial Product Bundling: A Case Study of Housing Loan Bundling by Kasikorn Bank Public Co., Ltd

By Salinthip Uttamawattana

Supervisor: Dr. Winai Wongsurawat

Research Study: Government Assistance Towards Industrial Linkage in Thailand Automotive Industry

By Eakapoom Wongsahai

Supervisor: Dr. Winai Wongsurawat

Research Study: Gravity Analysis of Pakistan's Exports: 1962-2008

By Farhat Mahmood

Supervisor: Dr. Arun Kumar Gopalaswamy

Research Study: Impacts of Liberalization on Vietnam's Banking Sector

By Ho Thuy Ai

Supervisor: Dr. Winai Wongsurawat

Research Study: Managing Research in Business and Management Subject Areas: Comparative Case Studies of Selected Business Schools in Thailand and New Zealand

By Bhusaba Taecharoen

Supervisor: Dr. Do Ba Khang

Research Study: Payment Instruments Between Thai Exporters and African Buyers

By Surapa Ruthirunkorn

Supervisor: Dr. Do Ba Ba Khang

Research Study: The Determinants of Net Interest Margin (NIM) in the Sri Lankan Banking System

By D.M. Jayasena

Supervisor: Dr. Winai Wongsurawat

Research Study: The Relationship Between Oil Consumption and Gross Provincial Product (GPP): A Case study of Thailand

By Sirin Rattanadilok Na Phuket

Supervisor: Dr. Winai Wongsurawat

Research Study: True Convergence: A Strategic Planning in Mobile

Telecommunications Industry in Thailand

By Isara Narathip
Supervisor: Dr. Yuosre F. Badir

Research Study: Why Does Mainland China Pay More: A Research Study of Dual-Listed Stocks in Mainland China and Hong Kong Stocks Exchanges

By Chai Xiaying
Supervisor: Dr. Sundar Venkatesh

Project: A Study of Employees' Satisfaction and Motivation at the Power Systems Department, Tata Steel, India

By Devanshu Verma
Supervisor: Dr. Winai Wongsurawat

Project: Brand Evaluation and Go To Market Strategy for Himalayan Spring Mineral Water, Nepal

By Prapti Dhungana
Supervisor: Dr. Rian Beise-Zee

Project: Communication Strategy in Culturally Diverse Countries: Launch of Vio by Coca-Cola Company in the US

By Laurent Pequignot
Supervisor: Dr. Rian Beise-Zee

Project: Competitive Analysis of the Wind Turbine Manufacturing Industry: Influencing the Power of Five Forces

By Eunmi Noh
Supervisor: Dr. Yuosre F. Badir

Project: Enhancing Foreign Language Proficiency of Employees to Meet the Job Requirements at ICMB (PVFCCo.) in Vungtau, Vietnam

By Mrs. Bui Thi Tuyet
Supervisor: Dr. Sununta Siengthai

Project: Financial Risk Management: Theories, Models and Practices

By Vivek Krishna Chandrahasan
Supervisor: Dr. Sundar Venkatesh

Project: Management Strategies and Technologies Assessment in Healthcare Industry Business: The Case Study of Bumrungrad International Hospital in Thailand

By Hathaichanok Anaraki
Supervisor: Dr. Yousre Badir

Project: Merger and Acquisition in Banking Sector: A Case Study of "CIMB Thai Public Company Limited"

By Rodjarek Nilvanich
Supervisor: Dr. Winai Wongsurawat

Project: Payments Made Between Thailand and Africa for International Trade

By Mathew Kuruville
Supervisor: Dr. Winai Wongsurawat

Project: Polish Construction Market Attractiveness - Morse Plc Case

By Katarzyna Kaczmarek
Supervisor: Dr. Winai Wongsurawat

Project: The Composition and Compensation Practices of Board of Directors: Evidence from Research Study in Vietnam

By Lai Thi Hai Linh
Supervisor: Dr. Sundar Venkatesh

Project: The Future of Medical Education as a Pharmaceutical Marketing Strategy at Eli Lilly Europe

By Vincent Wing-Yin Tam
Supervisor: Dr. Sununta Siengthai

Project: Toyota Appraisal System for International Assignment

By Pakpong Pakdeengam
Supervisor: Dr. Sununta Siengthai

International Business

Research Study: Electronic Viral Marketing: Factors Influencing E-mail Forwarding Behaviors Among Thai Users

By Thanunporn Tovanasutr
Supervisor: Dr. Donyaprueth Krairit

Human Resources Management

Research Study: Can Training Help Motivate VVWs to Increase Animal Vaccination: The Case of Village Veterinary Workers (VVWs)

By Douangchanh Sirivongsa
Supervisor: Dr. Sununta Siengthai

Research Study: Developing a Training Strategy for Middle Managers at FPT Software Company: A Case in Vietnam

By Ho Thi Viet Huong
Supervisor: Dr. Sununta Siengthai

Research Study: Effective Human Resource Practices to Retain Employees: A Case Study from the Economic Institute of Cambodia

By Pheakdey Sokunthea Sao
Supervisor: Dr. Sununta Siengthai

Research Study: Effective Performance Management System Implementation: The Case of Mekong River Commission

By Bounthanome Mixap
Supervisor: Dr. Nicholas J. Dimmitt

Research Study: Enhancing Effective Human Resources Strategy

By Samketh Nilyn
Supervisor: Dr. Sununta Siengthai

Research Study: Enhancing Succession Planning at a Petroleum Well Logging Company, Ho Chi Minh City, Vietnam

By Dang Thi Hoang Oanh
Supervisor: Dr. Sununta Siengthai

Research Study: Human Resources Management and Industrial Relations Approaches in the Resolution of Workplace Conflict: Practices in Vietnam

By Duong Thi Thanh Binh
Supervisor: Dr. Sununta Siengthai

Research Study: Strengthening Staff Motivation: A Case Study of Trade Promotion Department, Ministry of Commerce, Kingdom of Cambodia

By Sean Sophea
Supervisor: Dr. Sununta Siengthai

Research Study: The Balanced Scorecard Application: The Case of the Head Office of Bao Viet Insurance Corporation, Hanoi, Vietnam

By Pham Thi Hoai Minh
Supervisor: Dr. Sununta Siengthai

Research Study: Training Needs Assessment for Capacity Building of Staff in the National Office of the Poverty Reduction Fund (PRF) in Vientiane, Lao PDR

By Viengxay Phouangchan
Supervisor: Dr. Sununta Siengthai

International Business - Management of Technology

Research Study: Building an Effective and Efficient Supply Chain

Department for Schlumberger Vietnam Services

By Tran Thi Thuy Trang

Supervisor: Dr. Huynh Trung Luong

Project: A 5-Year Strategy for Ho Chi Minh Power Company Trading Corp. Building Project

By Nguyen Quang Vinh

Supervisor: Dr. Winai Wongsurawat

Project: A Business Plan for Vietnam Sourcing and Distribution Solution (SDS)

By Tran Xuan Quang

Supervisor: Dr. Winai Wongsurawat

Project: A Case Study of the Siam Commercial Bank PCL: The Role of SCB English Lab

By Udom Rotjanavanit

Supervisor: Dr. Logan Muller

Project: A Competency-Based Approach for Developing the Employees of Rahimafrooz Superstores Limited in Bangladesh: Materializing Vision 2014

By Muhammad Shakhawat Hossain

Supervisor: Dr. Winai Wongsurawat

Project: A Development Strategy for Petrovietnam Exploration and Production Corporation 2015 to 2025

By Dang Viet Long

Supervisor: Dr. Yuosre F. Badir

Project: A Marketing Strategy for Thanh An - Hanoi Company Ltd.

By Nguyen Dang Thuyet

Supervisor: Dr. Fredric W. Swierczek

Project: A Marketing Strategy for ZPV's Aquatabs - A New Water Sanitation Treatment Product in Vietnam

By Tran Thi Thu Ha

Supervisor: Dr. Winai Wongsurawat

Project: An Expansion Strategy for Tan Mai Group Joint - Stock Company

By Tran Thi Ngoc Huong

Supervisor: Dr. Winai Wongsurawat

Project: A Sustainable Strategy for the Oil and Gas Enterprise of Vietsovpetro Joint Venture

By Trinh Hoang Linh

Supervisor: Dr. Rian Beise-Zee

Project: Brand Positioning for King Care Pharmacy

By Nguyen Thi Mai Hanh

Supervisor: Dr. Rian Beise-zee

Project: Budget Process Improvement: Zero-Based Budgeting in Thai Indo Kordsa Ltd.

By Melek Kucuk

Supervisor: Dr. Nicholas J. Dimmitt

Project: Building a Business Strategy for the Real Estate Department of Ha Tien 1 Cement JSC

By Le Anh Dung

Supervisor: Dr. Logan Muller

Project: Building Ha Tien 1 Corporate Culture

By Le Tuan Thien

Supervisor: Dr. Sununta Siengthai

Project: Business Plan for Quality Control Service for Furniture at the Vietnam of Dai Quoc Co., Ltd.

By Nguyen Thanh Nhan

Supervisor: Dr. Winai Wongsurawat

Project: Business Strategy for Minh Anh Trading Joint Stock Company

By Do Anh Tuan

Supervisor: Dr. Winai Wongsurawat

Project: Calculating the Charges for the Power Transmission Activities in the Competitive Market of Vietnam

By Nguyen Tan Dat

Supervisor: Mr. Ragnar Soeggard

Project: Change for Survival and Development: A Case of Sonacons (Reorganizing the Structure)

By Nguyen Duy Hoang

Supervisor: Dr. Winai Wongsurawat

Project: Communication at Oxford Press University

By Hoang Thi Thu Thuy

Supervisor: Dr. Nicholas J. Dimmitt

Project: Competitive Bidding Cost Analysis for Van Kien Phat Company

By Pham The Anh

Supervisor: Dr. Do Ba Khang

Project: Competitive Strategy Analysis for Mai Linh Express Company

By Pham Minh Canh

Supervisor: Dr. Do Ba Khang

Project: Consumer Awareness and Perception on Durex Brand in Vietnam

By Thai Phuong Oanh

Supervisor: Dr. Rian Beise-zee

Project: Creating Value in Human Resources in the Production Department of Ha Tien 1 Cement Joint Stock Company

By Ly Hong Vinh

Supervisor: Dr. Sununta Siengthai

Project: Credit Quality Improvement: The Case of Vietnam Technological and Commercial Joint Stock Bank-Vung Tau Branch, Baria Vung Tau, Vietnam

By Nguyen Minh Thong

Supervisor: Dr. Sundar Venkatesh

Project: Customer Satisfaction for Improving Service Performance: The Case of DKSH Vietnam

By Nguyen Kim Phuong

Supervisor: Dr. Yuosre Badir

Project: Customer Satisfaction on Production Process of NC Housing Public Company Limited

By Vichit Vichaisarn

Supervisor: Dr. Nicholas J. Dimmitt

Project: Customer Service - A Case Study of EVN IT

By Luong Dinh Viet

Supervisor: Dr. Fredric W. Swierczek

Project: Customer Service Management at Dalat Academy

By Vu Chi Mai

Supervisor: Dr. Nicholas J. Dimmitt

Project: Developing a Business Strategy for Electro Mechanical Company (EMEC), Vietnam

By Nguyen Ngoc Khanh

Supervisor: Dr. Winai Wongsurawat

Project: Developing a Business Strategy for Ho Chi Minh City General Power Company - HCMPC - EVN

By Pham Quoc Bao

Supervisor: Dr. Winai Wongsurawat

Project: Developing a Business Strategy for Tin Nghia Construction Materials Company

By Le Son Tung
Supervisor: Dr. Winai Wongsurawat

Project: Developing a Local Maintenance Management in Ha Tien 1 Cement Joint Stock Company

By Nguyen Minh Man
Supervisor: Dr. Yousef Badir

Project: Developing a Marketing Strategy: The Case of Vietsovetro Logging & Testing Division

By Huynh Van Trong
Supervisor: Dr. Rian Beise-Zee

Project: Developing an Integrated "Door-to-Door" Logistics Service for PTSC Shipping Agency Co., Ltd.

By Nguyen Quoc Hoang
Supervisor: Dr. Winai Wongsurawat

Project: DKSH Vietnam: Right Targeting Customers to Optimize Sales Strategy

By Nguyen Thi Kim Cuong
Supervisor: Dr. Yousef Badir

Project: Effective Strategies for Human Resource Management: A Case Study of Sonadezi Long Thanh Joint Stock Company

By Truong Viet Hoang Son
Supervisor: Dr. Sununta Siengthai

Project: Enhancing Organizational Transformation Change: A Case Study of Mechanical and Electrical Division - A Subsidiary of J.V. Vietsovetro, Vung Tau City, Vietnam

By Nguyen Tien Vinh
Supervisor: Dr. Winai Wongsurawat

Project: Enhancing the Competitive Capability of Phu My Thermal Power Company in Vietnam's Power Market

By Nguyen Chon Cam
Supervisor: Dr. Winai Wongsurawat

Project: Establishing the Mechanism for Regulating the Activities of a Market

By Le Khac Hung
Supervisor: Mr. Ragnar Soeggard

Project: Exchange Rate Risk Management in Vietnam: Examples of Holcim and Ha Tien 1

By Huynh Thi Nhu Tran
Supervisor: Dr. Sundar Venkatesh

Project: Expanding Strategies for Ha Tien 1 Cement Joint Stock Company in the South of Vietnam

By Dang Thi Phuong Tho
Supervisor: Dr. Logan Muller

Project: Expanding the Domestic Market Share of Ha Tien 1 Cement J.S. Company

By Ho Hai Cuong
Supervisor: Dr. Winai Wongsurawat

Project: Factors Affecting Infant Formula Consultation and Selection: The Case of Vietnam

By Nguyen Thi Kim Thoa
Supervisor: Dr. Winai Wongsurawat

Project: Greening the SCG Brand: An Exploratory Story in Vietnam

By Luu Thi Thanh Thao
Supervisor: Dr. Rian Beise-zee

Project: Growth Strategy Management: A Case Study of Cuong Thuan Idico Company

By Tran Nhu Hoang
Supervisor: Dr. Winai Wongsurawat

Project: How to Apply the Project Management Theory to Develop the PTSC Offshore Services Vung Tau, Vietnam

By Le Toan Thang
Supervisor: Dr. Do Ba Khang

Project: How Young Leaders Cultivate Successful Working Relationships with Older Employees: A Case Study from Vietnam

By Trang Thuy Tran
Supervisor: Dr. Winai Wongsurawat

Project: Human Resource Development Strategic Planning by 2015 for the Bag Production Workshop of Ha Tien 1 Cement Joint Stock Company

By Le Tuan Dung
Supervisor: Dr. Sununta Siengthai

Project: Human Resource Management after Equitization: The Case of Sonadezi Long Binh

By Ha Diep
Supervisor: Dr. Sununta Siengthai

Project: Implementation of Supply Chain Management for Improving

the Inventory Management in VIETSOVETRO Joint Stock Company Vung Tau, Vietnam

By Le Quang Man
Supervisor: Dr. Huynh Trung Luong

Project: Improvement of Motivation and Training for Investment and Development of Industrial Zone and Residential Area Company (IDIZRA)

By Pham Thi Anh Dao
Supervisor: Dr. Sununta Siengthai

Project: Improving Human Resource Management in a Construction Company: The Case of Sonadezi Chau Duc Shareholding Company

By Do Quoc Bao
Supervisor: Dr. Sununta Siengthai

Project: Improving Human Resource Planning at the Joint Venture Vietsovetro, Vung Tau, Vietnam

By Vu Viet Kieu
Supervisor: Dr. Sununta Siengthai

Project: Improving Productivity in Unipax Co., Ltd.: A Comparative Study of Firms in the DADA Corporation Network

By Nguyen Van Tien
Supervisor: Dr. Sununta Siengthai

Project: Improving the Accuracy of the Forecasted Power Demand in Power

By Dinh Trung Kien
Supervisor: Mr. Ragnar Soegaard

Project: Improving the Competitive Advantages of Mechanical and Electrical Service Division - Vietsovetro, Vung Tau, Vietnam

By Nguyen Trong Nghiem
Supervisor: Dr. Winai Wongsurawat

Project: Improving the Competitiveness of New Products Department - Ha Tien 1

By Phan Le Nhan
Supervisor: Dr. Winai Wongsurawat

Project: Improving the Domestic Distribution System of Vinacafe Bien Hoa Joint-Stock Company

By Tran Thi Minh Thao
Supervisor: Dr. Winai Wongsurawat

Project: Improving the Effectiveness of the Transportation and

Construction Joint-Stock Company (DOTRANCO)

By Nguyen Van Huy
Supervisor: Dr. Winai Wongsurawat

Project: Improving the Enterprise Data Warehouse Project Management for Siam Commercial Bank Public Company Limited

By Kasin Wongwattananat
Supervisor: Dr. Nicholas J. Dimmitt

Project: Improving the Purchasing Process of Goods and Services for Operational Activities in J/V Vietsovpetro, Vung Tau, Vietnam

By Truong Thanh Son
Supervisor: Dr. Winai Wongsurawat

Project: Improving the Quality of Staff in Petroleum Technical Services Corporation, Vietnam

By Pham Hung Phuong
Supervisor: Dr. Sununta Siengthai

Project: Improving the Quality of Vocational Training and Education: The Case of Petrovietnam Manpower Training College (PVMTC)

By Hoang Tien Thang
Supervisor: Dr. Nicholas J. Dimmitt

Project: Improving the Supply Chain Management at the Cement Production Department in Hatien 1 Cement Joint Stock Company

By Phu Thanh Duy
Supervisor: Dr. Yousef F. Badir

Project: Increasing Effectiveness through Process Re-design

By Navdib Moktan
Supervisor: Dr. Rian Beise-Zee

Project: Increasing Sales for V-Trac Infrastructure Development Company in Vietnam

By Nguyen Thi Hong Ly
Supervisor: Dr. Winai Wongsurawat

Project: Inventory Management in Trading Operations: A Study of PVFCCO

By Ho Tuan Hung
Supervisor: Dr. Sundar Venkatesh

Project: Job Satisfaction at a Private University in Vietnam

By Le Mong Diem Hang
Supervisor: Dr. Sununta Siengthai

Project: Joint Venture Success: Establishment of a Joint Venture Consulting Business Between a Local and an International Firm: A Case Study from Vietnam

By Nguyen Phuong Chi
Supervisor: Dr. Logan Muller

Project: Lifting Cleaner Production (CP) Barriers in Vietnam: Proposing a New Dissemination Strategy

By Nguyen Thi Lam Giang
Supervisor: Dr. Winai Wongsurawat

Project: Maintaining and Improving the Quality System at the Fpt Information System Corporation

By Pham Thu Lien
Supervisor: Dr. Yousef F. Badir

Project: Maintaining Sustainable Growth in the Vietnamese Hospitality Market: The Case of Infotel

By Phan Phuc Hung
Supervisor: Dr. Winai Wongsurawat

Project: Marketing Mix Strategy for a New Variant "Men's Biori Double Oil Control Facial Foam"- Kao Vietnam's Power Market

By Nguyen Thi Ai Nuong
Supervisor: Dr. Winai Wongsurawat

Project: Marketing Mix Strategy Through Motivation in Port Management and Customer Policy

By Pham Van Huy
Supervisor: Dr. Winai Wongsurawat

Project: Marketing Strategy for Foreign Language Centers in Vietnam: A Case Study of ILA Vietnam

By Tran Truc Uyen
Supervisor: Dr. Nicholas J. Dimmitt

Project: Maximo Computerized Maintenance Management System (CMMS) Development and Implementation Project for Su Tu Vang (Golden Lion) Oil Field at Cuu Long Joint Operating Company (CLJOC), Vietnam

By Dang Anh Tuan
Supervisor: Dr. Do Ba Khang

Project: New Strategy for EVN Telecom Internet Service

By Nguyen Truong Giang
Supervisor: Dr. Fredric W. Swierczek

Project: Nuclear Power Introduction in Vietnam: Challenges and Approaches Toward their Solutions

By Dinh Thi Thanh Lan
Supervisor: Dr. Yousef F. Badir

Project: Opportunities and Challenges in Developing Wind Projects in Vietnam

By Tran Thi Bich Phuong
Supervisor: Dr. Winai Wongsurawat

Project: Out-of-Stock Situation Analysis at Metro Cash a Carry Vietnam

By Vo Van Nam
Supervisor: Dr. Do Ba Khang

Project: Payment in the Power Market of Vietnam

By Pham Viet Hung
Supervisor: Prof. Nazrul Islam

Project: Performance of a Bond Market in Asia: A Case Study of Vietnam

By Nghiem Chi Minh
Supervisor: Dr. Sundar Venkatesh

Project: Process Improvement in Technip Engineering (Thailand) Limited

By Dharmesh Vrajlal Brahmabhatt
Supervisor: Dr. Nicholas J. Dimmitt

Project: Production to Increase Competitive Advantages for Products of Timxcons Company*

By Vo Nhu Thanh Binh
Supervisor: Dr. Winai Wongsurawat

Project: Redesigning the Compensation System at the PTSC New Shipbuilding Division, Vung Tau, Vietnam

By Pham Quoc Tuan
Supervisor: Dr. Sununta Siengthai

Project: Re-positioning Safety and CSR at LINFOX Logistics

By Kavin Sopitpongstorn
Supervisor: Dr. Nicholas J. Dimmitt

Project: Restructuring the Business Model of a Ready-to-Drink Coffee Shop

By Kriangkrai Songkittiphong
Supervisor: Dr. Sununta Siengthai

Project: Restructuring the Information Process at Thanh An Ltd., Co.

By Nguyen Thu Phuong
Supervisor: Dr. Winai Wongsurawat

Project: Retaining and Motivating Staff for Effective Performance and Loyalty at Siam Cement Trading in Vietnam

By Le Huy Dat
Supervisor: Dr. Sununta Siengthai

Project: Risk Management in a Competitive Generation Market Applied for Pha Lai Thermal Power JSC

By Ngo Thi Thuy Hang
Supervisor: Dr. Fredric Swierczek

Project: Solving the Problem of Power Loss at Hanoi Power Company

By Do Dac Bang
Supervisor: Dr. Weerakorn Ongsakul

Project: Sonadezi Corporation-Business Strategy for Industrial Park Development

By Duong Khanh Hung
Supervisor: Dr. Winai Wongsurawat

Project: Strategy for Development of the Institute of Energy in the Period 2010-2020 and Outlook for 2030

By Pham Minh Hoa
Supervisor: Dr. Winai Wongsurawat

Project: Strategy to Develop the Human Resources of Petro Vietnam Power Engineering for the Years of 2009-2015

By Ngo Vu An
Supervisor: Dr. Sununta Siengthai

Project: Strategy to Develop the Shielded Intravenous Catheter in Vietnam

By Nguyen Thi Bach Tuyet

Supervisor: Dr. Yuosre F. Badir

Project: Strategy to Enhancing the Market Share of Monsanto Vegetable Seed in Vietnam from 2010-2014

By Nguyen Thi Hoa
Supervisor: Dr. Yuosre F. Badir

Project: Technology Management of the Thacmo Hydro Power Project

By Dao Nguyen Hanh
Supervisor: Dr. Yuosre F. Badir

Project: The Business Environment in the Rural Area of Vietnam in 2008

By Lo Thi Duc
Supervisor: Dr. Winai Wongsurawat

Project: The Demand for Training to Develop Work Capacity at the Maintenance Department of Thu Duc Grinding Station - Ha Tien 1 Joint Stock Company

By Dao Duc Thuong
Supervisor: Dr. Logan Muller

Project: The Improvement of Procurement Performance via Supply Chain Management and Corporate Knowledge Management: A Case Study

By Chi-sheng Chuang
Supervisor: Dr. Nicholas J. Dimmitt

Project: The International Business Model and Value Chain of Certified Emission Reduction: A Case Study from Vietnam

By Chu Van Giap
Supervisor: Dr. Winai Wongsurawat

Project: The Potential Risks in Maintenance Quality Management at Thuduc Terminal Ha Tien 1: Joint Stock Company

By Tran Anh Kiet
Supervisor: Dr. Yuosre Badir

Project: The PTT Foundation: Power for a Sustainable Future

By Kamonwan Wongvilai
Supervisor: Dr. Nicholas J. Dimmitt

Project: The Relationship Between Corporate Culture and Organizational Commitment in Ha Tien 1 Cement Joint Stock Company

By Nguyen Minh Ngoan
Supervisor: Dr. Logan Muller

Project: The Use and Demand for Labor in Nonagriculture Cooperatives

By Do Nhu Hung
Supervisor: Dr. Winai Wongsurawat

Project: TMB Wealth Banking Products: Development and its Impact for Creating Competitive Advantage in Thailand

By Napalada Yothaphant
Supervisor: Dr. Logan Muller

Project: Understanding Carve Outs: What Does Carve Out Mean for SIS

By Anant Thakral
Supervisor: Dr. Sundar Venkatesh

Project: Understanding the Cultural Problems that Expatriates Face in Vietnam

By Tran Thai Tan
Supervisor: Dr. Winai Wongsurawat

Project: VIETCOMBANK – The Brand Name is an Advantage in International Settlement Activities

By Tran Thi Phuong Chi
Supervisor: Dr. Clemens Bechter

Project: Western Digital: The Happy Workplace

By Tawan Suppapunt
Supervisor: Dr. Winai Wongsurawat

Chapter 7: AIT EXTENSION

7.1 Introduction

AIT Extension is responsible for non-degree programs at AIT. As the continuing and professional education center of the institute, we are responsible for the delivery of short-courses to a wide array of capacity-building projects in different sectors and consultancy services, and in this way contribute to the realization of AIT's mission to develop highly qualified and committed professionals who play a leading role in the sustainable development of the region and its integration into the global economy. AIT Extension works with professionals in national governments, overseas development agencies, multilateral agencies, development institutions, private sector, development banks, consultants and NGOs.

AIT Extension's operating programs are:

- Agriculture, Resources and Environment
- Education and Training Development
- Public Sector Capacity Building
- Development Management
- Information Technology and Engineering

7.2 Mission

To identify and respond to regional opportunities for continuing professional education, training and consultancy, and thus help to realize AIT's mission to develop highly qualified and committed professionals who will play a leading role in the sustainable development of the region and its integration into the global economy.

7.3 Unit Governance

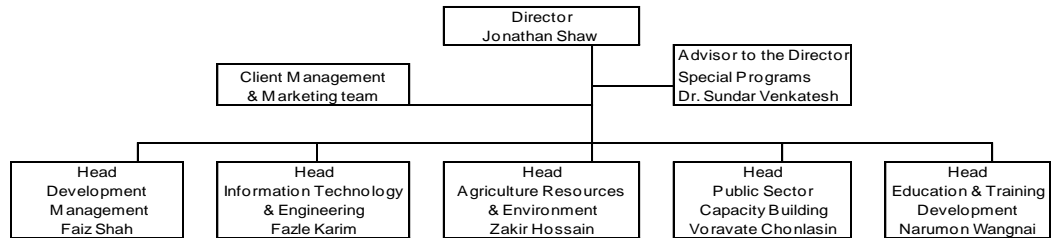

with our clients to develop unique training solutions that meet their specific needs. This process will

7.4 Courses and Services

AIT Extension offers courses in the following specializations:

- Agriculture and Food Processing
- Environment and Natural Resources Management
- Education and Training Development
- Poverty Reduction and Livelihoods Development
- Business Performance, Management and Strategy
- Development Effectiveness
- Public Sector Services and Management
- Private Sector Development
- Information and Communication Technologies
- Information and Communication Management
- Infrastructure Development and Public Utility Management

International professional development courses usually last from one to three weeks.

Customized Courses

AIT Extension specializes in designing, developing and implementing short courses to the specifications of particular client organizations. Every organization with which we work is unique, and change interventions required by our clients are most usually specific to that organization. Wherever required, therefore, we work closely

usually start with the clients' own terms of reference, to which AIT Extension responds. Meetings are scheduled with the client to discuss all aspects of the required training, and to ensure that the client's needs are met.

Exposure Visit Programs

Many professionals are interested in field visits to observe best practices in their field. Exposure visits are designed to provide senior government officials and decision makers with opportunities to visit and observe current technology and practices in their fields, to exchange information, to exchange experiences with local counterparts, project personnel and beneficiaries on development and management of similar projects, and to exchange views with participants from other countries. At the end of each program, a seminar is conducted at AIT to enable participants to reflect on what has been learned and what can be adapted to their own development contexts.

Thailand provides numerous examples of best practice in a wide diversity of fields. AIT Extension is also experienced in organizing exposure visit programs to many countries in the region, with recent experience in Vietnam, Laos, Malaysia, Korea, Philippines, Indonesia, Singapore and the UK.

Consulting Services

AIT Extension professional staff offer a wide range of technical assistance and consulting services. These include:

- Human Resource Development:** Development of human resource development (HRD) programs and projects; assessment of training needs in organizations; evaluation of training courses, projects or plans; review and evaluation of the management and operation of training centers; management and implementation of training development projects.
- Educational Development:** Curriculum design and development; evaluation of educational programs and projects; management and implementation of educational development projects; report writing and documentation.
- Information Technology:** Strategic information technology planning; information system analysis and design; IT project management.

7.5 Learning Approach

AIT Extension's approach to teaching and learning is to apply best practices in training, based on established principles of adult learning: peer learning, reflective thinking, problem-based learning, participatory learning and experiential learning. We aim to maximize learning by mixing these approaches appropriate to each learning context.

Methods used include short presentations, group discussions, case studies, workshops, individual exercises, simulation, role-plays, project work, peer learning and exposure visits. Training sessions are designed to allow participants the scope to interact with resource persons and actively engage in the learning process.

Participants benefit from close personal attention by AIT Extension staff. Our typical training course provides five to six hours of workshop sessions every weekday, with extensive social and cultural trips organized at the weekends in courses of two weeks or longer.

ICTs relevant and appropriate to every group of participants are incorporated into the course design.

Feedback from participants in one course is a critical input to subsequent courses. All our training courses are undertaken with the aim of continuous quality improvement.

All AIT Extension activities take advantage of AIT's stimulating academic and social environment, and the Institute's multicultural English-speaking academic community.

7.6 Training Resources

AIT Extension has a wide pool of academic and professional resource persons drawn from AIT's schools, and from leading national agencies, and international and local organizations in the region.

Professional staff who are specialists in human resources development, curriculum planning, instructional system design, information technology application development and other specific technological areas.

State-of-the-art educational and information technologies incorporated into all training facilities on campus.

AIT's campus: a serene and relaxing environment for study. Hotel and student dormitory accommodation, a medical clinic, an international cafeteria, several restaurants and sports facilities including tennis and squash courts, a golf course and a swimming pool.

7.7 Courses Completed in 2010

14th Fredskorpset Preparatory Course in Asia

Duration: 22 Mar 10 - 09 Jul 10
 Course Coordinator(s): Warindhorn Srina
 Sponsor: Fredskorpset Norway
 Total contracted amount: THB 2,473,882.-

3rd Certificate Course in Management Consulting Essentials

Duration: 22 Feb 10 - 26 May 10
 Course Coordinator(s): Bahul Raj Shrestha
 Sponsor: Multi donors
 Total contracted amount: THB 660,600

Advance Competencies for Trainers (Training)

Duration: 09 Nov 09 - 25 Feb 10
 Course Coordinator(s): Kanlaya Muangsan
 Sponsor: Government of India & PRMP Pakistan
 Total contracted amount: THB 1,070,429

Advanced Risk Management for Banking Professionals

Duration: 25 Jul 10 - 25 Oct 10
 Course Coordinator(s): Parichard Nuntavong
 Sponsor: South Asian and Middle East Market of Basel Knowledge
 Total contracted amount: THB 481,320

Advanced Strategies in Public Management

Duration: 10 Jun 10 - 14 Sep 10
 Course Coordinator(s): Rowena C Alcoba
 Sponsor: Ministry of Local Development Nepal
 Total contracted amount: THB 334,213

AIT- NCED Institutional Linkage for Capacity Building Program

Duration: 12 Dec 09 - 24 Mar 10
 Course Coordinator(s): Kanlaya Muangsan
 Sponsor: ESAT-DANIDA, Nepal
 Total contracted amount: THB 619,250

AIT-NCED Institutional Linkage for Capacity Building Program

Duration: 01 Aug 08 - 31 Mar 10
 Course Coordinator(s): Reynaldo Calabdan
 Sponsor: ESAT DANIDA Nepal
 Total contracted amount: THB 4,213,708

Capacity Development for Effective Organizational Performance

Duration: 23 Jun 10 - 29 Sep 10
 Course Coordinator(s): Upul Kaluhetti Brahmanage
 Sponsor: Ministry of Local Development Nepal
 Total contracted amount: THB 483,533

Capacity Enrichment Program on Life Competencies and Civic Education

Duration: 05 Jul 10 - 13 Oct 10
 Course Coordinator(s): Warindhorn Srina
 Sponsor: Ministry of Education Sri Lanka
 Total contracted amount: THB 632,469

Construction Management

Duration: 10 May 10 - 19 Aug 10
 Course Coordinator(s): Worawan Sumroetrum
 Sponsor: PRMP Government of Punjab Pakistan
 Total contracted amount: THB 1,326,749

Design and Development of Instructional Materials using Desktop, Web and Multimedia Tools

Duration: 02 Nov 09 - 31 Jan 10
 Course Coordinator(s): Thaniya Jirasathitpornpong
 Sponsor: Multi donors
 Total contracted amount: THB 490,782

Education Planning Budgeting and Monitoring

Duration: 23 Nov 09 - 04 Mar 10
 Course Coordinator(s): Upul Kaluhetti Brahmanage
 Sponsor: MOE Sri Lanka
 Total contracted amount: THB 822,250

Effective Regulation of Infrastructure Utilities Batch I

Duration: 24 May 10 - 02 Sep 10
 Course Coordinator(s): Upul K. Brahmanage
 Sponsor: Bangladesh Energy Regulatory Commission
 Total contracted amount: THB 1,000,420

Effective Regulation of Infrastructure Utilities Batch II

Duration: 07 Jun 10 - 30 Sep 10
 Course Coordinator(s): Upul K. Brahmanage
 Sponsor: Bangladesh Energy Regulatory Commission
 Total contracted amount: THB 1,004,420

Energy Savings for Fluid Machinery Equipment and Effective Usage

Duration: 25 Aug 10 - 29 Nov 10
 Course Coordinator(s): Worawan Sumroetrum
 Sponsor: EBARA
 Total contracted amount: THB 190,555

Environment and Social Safeguard

Duration: 22 Mar 10 - 28 Jun 10
 Course Coordinator(s): Parichard Nuntavong
 Sponsor: Ministry of Local Development Nepal
 Total Contracted Amount : THB 795,802

Environmental and Social Safeguard

Duration: 17 May 10 - 23 Aug 10
 Course Coordinator(s): Parichad Nuntavong
 Sponsor: Ministry of Local Development Nepal
 Total contracted amount: THB 798,995

Financial Management, Accounting, Planning and Projections

Duration: 26 Oct 09 - 04 Feb 10
 Course Coordinator(s): Upul Kaluhetti Brahmanage
 Sponsor: Government of Sri Lanka
 Total contracted amount: THB 639,732

General Banking and Management of Central Banks for NRB

Duration: 05 Jul 10 - 07 Oct 10
 Course Coordinator(s): Upul Kaluhetti Brahmanage
 Sponsor: Nepal Rastra Bank
 Total contracted amount: THB 690,428

Hospital management in Tertiary Health Care Batch 2 & 3)

Duration: 28 Sep 09 - 20 Feb 10
 Course Coordinator(s): Voravate Chonlasin
 Sponsor: PRMP, Pakistan
 Total contracted amount: THB 2,518,847

Hospital Management in Tertiary Health Care Batch 4

Duration: 26 Apr 10 - 31 Jul 10
 Course Coordinator(s): Voravate Chonlasin
 Sponsor: Government of Punjab, Pakistan
 Total contracted amount: THB 1,158,545

Human Resource Management

Duration: 26 Apr 10 - 15 Sep 10
 Course Coordinator(s): Rowena C Alcoba
 Sponsor: Titus T&D Co. Ltd., Bangladesh
 Total contracted amount: THB 801,645

Human Resource Management Finance and Execution

Duration: 29 Mar 10 - 15 Sep 10
 Course Coordinator(s): Upul Kaluhetti Brahmanage
 Sponsor: Nepal Telecom
 Total contracted amount: THB 561,312

Human Resource Management Finance and Execution

Duration: 19 Aug 10 - 25 Nov 10
 Course Coordinator(s): Upul Kaluhetti Brahmanage
 Sponsor: Nepal Telecom
 Total contracted amount: THB 690,428

ICT/ICM for National Agricultural Research Information Systems in Asia Pacific region

Duration: 14 Sep 10 - 15 Dec 10
 Course Coordinator(s): Niramol Ponvilai
 Sponsor: Asia Pacific Association for Agricultural Research Institute
 Total contracted amount: THB 507,449

IEE and Environment

Duration: 01 Jul 10 - 05 Oct 10
 Course Coordinator(s): Phyu Sin
 Sponsor: Ministry of Local Development Nepal
 Total contracted amount: THB 434,330

Information Technology Audit

Duration: 31 May 10 - 29 Aug 10
 Course Coordinator(s): Willy Sanjaya
 Sponsor: Bangladesh Bank
 Total contracted amount: THB 1,982,592

IT Applications in Financial Management

Duration: 30 Aug 10 - 02 Dec 10
 Course Coordinator(s): Thaniya Jirasathitpornpong
 Sponsor: SIDA SAREC
 Total contracted amount: THB 262,937

IT Network Security

Duration: 05 Oct 09 - 21 Jan 10
 Course Coordinator(s): Agus S Prajogo
 Sponsor: Bangladesh Bank
 Total contracted amount: THB 1,550,451

Land Reclamation Development and Construction Management

Duration: 15 Feb 10 - 25 May 10
 Course Coordinator(s): AIT Ext
 Sponsor: LUNAWA Environment and Community Development Project Sri Lanka
 Total contracted amount: THB 727,040

Leading Change and Organizational Renewal

Duration: 02 Nov 09 - 04 Feb 10
 Course Coordinator(s): Rowena C Alcoba
 Sponsor: Bangladesh Bank, PIM and University of Kelaniya
 Total contracted amount: THB 528,944

Management of Training Centers and Manpower Planning

Duration: 29 Mar 10 - 30 Dec 10
 Course Coordinator(s): Voravate Chonlasin, Kanlaya Muangsan
 Sponsor: UNICEF/GDHR MMPW Government of Iraq
 Total contracted amount: THB 4,872,006

Marketing and Value Chain Management in Agriculture

Duration: 29 Mar 10 - 08 Jul 10
 Course Coordinator(s): Kanlaya Muangsan
 Sponsor: Palli Karma-Sahayak Foundation (PKSF), Bangladesh; Multi donors
 Total contracted amount: THB 814,660

MATT-2: 3rd Regional Exposure Visit Program (Batch 21)

Duration: 29 Nov 09 - 11 Mar 10
 Course Coordinator(s): Voravate Chonlasin
 Sponsor: DFID
 Total contracted amount: THB 5,089,128

MATT2-2nd Regional Exposure Visit Program (Batch 22)

Duration: 25 Jan 10 - 06 May 10
 Course Coordinator(s): Mr. Voravate Chonlasin
 Sponsor: DFID
 Total contracted amount: THB 5,172,349

MATT2-2nd Regional Exposure Visit Program (Batch 26)

Duration: 09 Aug 10 - 20 Nov 10
 Course Coordinator(s): Voravate Chonlasin
 Sponsor: DFID
 Total contracted amount: THB 5,559,945

Monitoring and Evaluation in Post Conflict Recovery

Duration: 22 Feb 10 - 01 Jun 10
 Course Coordinator(s): Voravate Chonlasin
 Sponsor: Ministry of Peace and Reconstruction, Nepal
 Total contracted amount: THB 444,992

Monitoring and Evaluation of Infrastructure Development Project

Duration: 28 Sep 09 - 07 Jan 10
 Course Coordinator(s): Worawan Sumroetrum
 Sponsor: PRMP, Pakistan
 Total contracted amount: THB 1,282,098

Office Management Skills using IT

Duration: 28 Jun 10 - 30 Sep 10
 Course Coordinator(s): Thaniya Jirasathitpornpong
 Sponsor: Bangladesh bank
 Total contracted amount: THB 701,835

Prawn Hatchery Operations and Management

Duration: 04 Oct 09 - 30 Apr 10
 Course Coordinator(s): Wichit Silpamaneephan
 Sponsor: Department of Fisheries and DANIDA Bangladesh
 Total contracted amount: THB 894,988

Professional Development Course on Curriculum Development and Implementation

Duration: 31 Aug 10 - 11 Dec 10
 Course Coordinator(s): Warindhorn Srina
 Sponsor: World Bank, Balkh University Afghanistan
 Total contracted amount: THB 913,238

Professional Training Course on Training for Trainers

Duration: 09 Nov 09 - 12 Feb 10
 Course Coordinator(s): Warindhorn Srina
 Sponsor: Government of India
 Total contracted amount: THB 1,070,492

Project Appraisal and Feasibility Study for Road Projects

Duration: 05 Jul 10 - 04 Nov 10
 Course Coordinator(s): Worawan Sumroetrum
 Sponsor: UNESCAP
 Total contracted amount: THB 3,473,600

Project Management and IT Application

Duration: 05 Jul 10 - 14 Oct 10
 Course Coordinator(s): Thaniya Jirasathitpornpong
 Sponsor: Titas Gas Company/ Bangladesh Bank
 Total contracted amount: THB 1,472,539

Project Management Monitoring and Evaluation

Duration: 17 May 10 - 02 Sep 10
 Course Coordinator(s): Upul Kaluhetti Brahmanage
 Sponsor: Titas Gas Company Bangladesh
 Total contracted amount: THB 1,021,768

Project Monitoring and Evaluation Focused on Poverty Reduction and MDG

Duration: 25 Jan 10 - 30 Apr 10
 Course Coordinator(s): Ms. Phyu Sin
 Sponsor: UNDP/LGSP-LIC
 Total contracted amount: THB 420,365

Project Planning and Quality Assurance

Duration: 23 Nov 09 - 25 Feb 10
 Course Coordinator(s): Phyu Sin
 Sponsor: Nepal Telecom
 Total contracted amount: THB 542,850

Study Visit on Program on Project Management and Application of ICT

Duration: 29 Apr 10 - 07 Aug 10
 Course Coordinator(s): Agus Prajogo
 Sponsor: LGED Bangladesh
 Total contracted amount: THB 739,600

Study Visit Program on Education Policy Planning and Implementation

Duration: 22 Aug 10 - 26 Nov 10
 Course Coordinator(s): Warindhorn Srina
 Sponsor: National education Commission, Sri Lanka
 Total contracted amount: THB 204,189

Sustainable Rural Development and Agricultural Practices using IT Applications

Duration: 23 Aug 10 - 30 Nov 10
 Course Coordinator(s): Willy Sanjaya
 Sponsor: Min of Agriculture and rural Development Ethiopia
 Total contracted amount: THB 686,031

Sustainable Urban Poverty Reduction Project Management

Duration: 21 Dec 09 - 29 Mar 10
 Course Coordinator(s): Worawan Sumroetrum
 Sponsor: UNDP Bangladesh
 Total contracted amount: THB 1,013,140

Urban Environmental Management

Duration: 09 Aug 10 - 18 Nov 10
 Course Coordinator(s): Zakir Hossain
 Sponsor: Multi donors
 Total contracted amount: THB 512,164

Water Supply Infrastructure and Social Development

Duration: 28 Jun 10 - 30 Sep 10
 Course Coordinator(s): Willy Sanjaya
 Sponsor: UN HABITAT Afghanistan
 Total contracted amount: THB 540,046

7.8 Courses Completed in 2010 (project account ongoing)

Agribusiness Management

Duration: 08 Nov 10 - 17 Feb 11
 Course Coordinator(s): Sujidtra Pumsombut
 Sponsor: Multi donors
 Total contracted amount: THB 480,157

Banking and Finance

Duration: 25 Oct 10 - 03 Feb 11
 Course Coordinator(s): Willy Sanjaya
 Sponsor: Bangladesh Bank
 Total contracted amount: THB 1,732,098

Data Organization and Analysis using Statistical Application

Duration: 22 Nov 10 - 24 Feb 11
 Course Coordinator(s): Thaniya Jirasathitpornpong
 Sponsor: SIDA SAREC
 Total contracted amount: THB 262,937

Database Development and Administration

Duration: 06 Dec 10 - 24 Mar 11
 Course Coordinator(s): Agus S. Prajogo
 Sponsor: Balkh University, Afghanistan
 Total contracted amount: THB 1,319,200

Essential Management Skills using IT

Duration: 27 Sep 10 - 06 Jan 11
 Course Coordinator(s): Thaniya Jirasathitpornpong
 Sponsor: Titas Gas T&D Co Ltd
 Total contracted amount: THB 1,738,889

Exposure Visit Program for Nepali Journalists

Duration: 01 Dec 10 - 30 Mar 11
 Course Coordinator(s): Kanlaya Muangsan
 Sponsor: Nepal Rastra Bank
 Total contracted amount: THB 182,362

Fellowship Program on Education Management and e Governance

Duration: 06 Sep 10 - 03 Feb 11
 Course Coordinator(s): Agus S. Prajogo
 Sponsor: UNESCO
 Total contracted amount: THB 301,900

Financial Management Accounting Planning and Projection

Duration: 01 Nov 10 - 14 Feb 11
 Course Coordinator(s): Faiz Shah
 Sponsor: MOE Sri Lanka
 Total contracted amount: THB 975,729

Hospital Management

Duration: 30 Aug 10 - 28 Feb 11
 Course Coordinator(s): Voravate Chonlasin
 Sponsor: Government of Karnataka, India
 Total contracted amount: THB 1,212,218

ICT for Management Skills Development

Duration: 22 Nov 10 - 03 Mar 11
 Course Coordinator(s): Agus S Prajogo
 Sponsor: Petro Bangla Co. Ltd.
 Total contracted amount: THB 918,531

ICT: e Governance in Asia

Duration: 29 Nov 10 - 03 Mar 11
 Course Coordinator(s): Agus S Prajogo
 Sponsor: Ecole Polytechnique Federale de Lausanne
 Total contracted amount: THB 585,357

Inland Waterways Transportation

Duration: 08 Nov 10 - 10 Feb 11
 Course Coordinator(s): Willy Sanjaya
 Sponsor: Ministry of Transportation, Indonesia
 Total contracted amount: THB 632,400

Integrated Solid Waste and Waste Water management

Duration: 11 Oct 10 - 27 Jan 11
 Course Coordinator(s): Phyu Sin
 Sponsor: Canadian Red Cross
 Total contracted amount: THB 1,206,652

International Exposure Program on MSME Financing

Duration: 27 Oct 10 - 01 Feb 11
 Course Coordinator(s): Faiz Shah
 Sponsor: College of Agricultural Banking/Reserve Bank of India
 Total contracted amount: THB 1,283,358

Macro Planning of Water Resources and Monitoring of Water Sector Projects

Duration: 22 Nov 10 - 03 Mar 11
 Course Coordinator(s): Zakir Hossain
 Sponsor: Water Resources Planning Organization, Bangladesh
 Total contracted amount: THB 813,865

Management and Implementation of Development Projects

Duration: 10 Oct 10 - 03 Feb 11
 Course Coordinator(s): Faiz Shah
 Sponsor: Multiple donors
 Total contracted amount: THB 347,946

Management Skills for Central Banks

Duration: 06 Dec 10 - 10 Mar 11
 Course Coordinator(s): Upul Kaluhetti Brahmanage
 Sponsor: Nepal Rastra Bank
 Total contracted amount: THB 645,670

MATT-2: 2nd Regional Exposure Visit Program (Batch 28)

Duration: 14 Nov 10 - 24 Feb 11
 Course Coordinator(s): Worawan Sumroetrum
 Sponsor: DFID
 Total contracted amount: THB 4,780,482

Organizational Strategic Planning and Management

Duration: 21 Dec 10 - 24 Mar 11
 Course Coordinator(s): Fazle Karim
 Sponsor: for Campaign for Popular Education, Bangladesh
 Total contracted amount: THB 394,372

Petroleum Exploration Technologies

Duration: 13 Dec 10 - 22 Mar 11
 Course Coordinator(s): Willy Sanjaya
 Sponsor: Petrobangla, Bangladesh
 Total contracted amount: THB 598,200

Professional development program on training of master trainers

Duration: 05 Dec 10 - 15 Mar 11
 Course Coordinator(s): Myint Myint Sein
 Sponsor: Institute for Microfinance Bangladesh
 Total contracted amount: THB 664,358

Project Monitoring and Evaluation focused on Poverty Reduction and MDGs

Duration: 20 Dec 10 - 25 Mar 11
 Course Coordinator(s): Worawan Sumroetrum
 Sponsor: UNDP Bangladesh
 Total contracted amount: THB 420,483

Public Private Partnership for elevated Road Project

Duration: 26 Sep 10 - 06 Jan 11
 Course Coordinator(s): Worawan Sumroetrum
 Sponsor: Department of Road Nepal
 Total contracted amount: THB 1,094,128

Road Safety Management

Duration: 01 Nov 10 - 03 Feb 11
 Course Coordinator(s): Willy Sanjaya
 Sponsor: Ministry of Transportation, Indonesia
 Total contracted amount: THB 637,400

SAP-AIT University Alliance Program

Duration: 01 Jan 10 - 31 Mar 11
 Course Coordinator(s): Fazle Karim, Mr. Agus Prajogo
 Sponsor: Multi donors
 Total contracted amount: THB 542,500

Souvenir Design and Development

Duration: 25 Nov 10 - 04 Mar 11
 Course Coordinator(s): Thaniya Jirasathitpornpong
 Sponsor: Katalyst Bangladesh
 Total contracted amount: THB 934,077

Special Development Management Training Program

Duration: 01 Nov 10 - 03 Mar 11
 Course Coordinator(s): Faiz Shah, Mr. Upul K. Brahmanage
 Sponsor: Government Pakistan, India, Bangladesh
 Total contracted amount: THB 1,517,622

Special Program on Public Organization Development

01 Sep 10 - 30 Mar 11
 Course Coordinator(s): Tidarat Vechvongvan
 Sponsor: UNDP, WHO, Ministry of Rural Rehabilitation and Development Afghanistan
 Total contracted amount: THB 1,206,030

Training for Trainers and Advance Competencies for trainers (Training)

Duration: 24 Jan 11 - 11 Feb 11
 Course Coordinator(s): Kanlaya Muangsan
 Sponsor: Government of India
 Total contracted amount: THB 1,463,529

UNDP Leadership Development Program

Duration: 10 Sep 10 - 15 Mar 11
 Course Coordinator(s): Worawan Sumroetrum
 Sponsor: UNDP Nepal
 Total contracted amount: THB 3,050,560

Waste Management and Renewable Energy Technologies with an Emphasis on Monitoring and Maintenance

Duration: 19 Dec 10 - 24 Mar 11
 Course Coordinator(s): Phyu Sin
 Sponsor: Det Norske Veritas, Norway
 Total contracted amount: THB 1,092,038

Chapter 8: INTERNET EDUCATION AND RESEARCH LABORATORY (intERLab)

8.1 Introduction

Continual expansion of the Internet is creating greater demand for well-trained human resources to support the infrastructures and applications of the Internet. New computer science and engineering solutions are needed to simply handle the exponential growth in the traffic and bandwidth usage which is putting severe strain on the Internet today. There is urgent need for a new breed of engineers and technologists to respond to the growing demand from this rapid expansion with endless range of new applications.

As the Internet continues to penetrate every corner of society and of the economy, there are other non-technical issues to be addressed along with the advancement of technological progress. There is a definite need for better understanding of the Internet's social, business, economic as well as legal implications in order to promote the standards of behaviour and practices for the community that are appropriate to continued growth and beneficial use of the Internet.

The intERLab was established in December 2003 as a fixed regional center for Internet infrastructure capacity building, where AIT based on its human and institutional networks, could play a very significant role for the region. Many Internet organizations such as the Network Startup Resource Center (NSRC) funded by NSF, the Asia-Pacific Network Information Centre (APNIC) and the Asia-Pacific Advanced Network (APAN) as well as many Internet business organizations provided strong support for the intERLab establishment.

The concept of establishing a fixed location for the internet human resources development has been discussed and endorsed by leading Asia-

Pacific Internet organizations at their AP* Retreat meeting at AIT in year 2000. Several leading research institutions in Asia-Pacific, Europe and the US have indicated their interests in forming up a network of support for the intERLab research, training and education. The main idea is to work together with partners on training and workshops in order to produce network engineers for the stable deployment of the Internet. It was also encouraged that the intERLab develops its own expertise by doing its own research and eventually become one of the leading Internet research centers in the region.

The core component of the laboratory will be on research activities. This will be achieved by maintaining excellent research facilities and staff, hosting visiting researchers and taking advantage of linkages with research laboratories worldwide. The lab was built upon pre-existing Internetworking Research Laboratory of the School of Advanced Technologies and the Distributed Education Center.

8.2 Mission

To become one of the leading Internet regional centers of excellence; establishing intERLab/AIT name, as one of the leading Internet infrastructure HRD centers in the Asia-Pacific region; launching our research products at the regional and international level; and developing a regular degree program under SET.

8.3 Unit Governance

Prof. Kanchana Kanchanasut
IntERLab Director

8.4 Resources

Education

Distance Education and E-Education Platform VClass

- VClass open source consortium
- VClass trainings for AIT faculty and staff
- VClass hosting service and technical support
- ASEAN Virtual Institute of Science and Technology (AVIST) hosting
- Custom courseware development;
- E-learning consultancy;
- Instructional design consultancy;
- Custom course design
- CanalAVIST streaming VDO over Trans-Eurasia Information Network (TEIN)

Research

Streaming Technology on the Internet

- DVRelay for streaming high quality Video (DV format) over heterogeneous network
- Overlay network for streaming content delivery

Computer Network Research

- Wireless Internet as information infrastructure for rural Asia
- Digital Ubiquitous Mobile Broadband OLSR emergency network project
- Multimedia communication over heterogeneous network

Training and Internet Information Center

Trainings for Network Infrastructure Engineers (7~8 courses per year)
 Human Resource Development for Trans-Eurasia Information Network
 Secretariats for AP* Retreat and Asia Pacific Networking Group (APNG) organizations

8.5 Faculty and Research Staff

Faculty

KANCHANA KANCHANASUT, M.Sc and Ph. D. Computer Science, University of Melbourne, Australia. Graduate Diploma in Computer Science, University of Queensland, Australia. B. Sc. Mathematics, University of Queensland, Australia.

Professor of Computer Science, School of Engineering and Technology and Director of intERLab. [*Internet for education; Heterogeneous Networks; Emergency Networks; Mobile Ad Hoc Networks; Streaming Media and Distributed Computing*]

Visiting Faculty

NOEL CRESPI, GET/INT, France; Ing. Dipl (ENST), MSc, PhD.

Visiting Professor. [*SIP; 3G Services; IP Multimedia Subsystem And Context Awareness B3G Core network and Service Architectures*]

YASUO TSUCHIMOTO, Keio University, Japan, PhD in Media and Governance, Keio University, Japan Master of Media and Governance, Keio University, Japan Bachelor of Arts in Environmental Information from Keio University, Japan

Visiting Assistant Professor. [*Computer Networks; Internet Education; Multimedia communication and Overlay network Adjunct Researchers*]

Affiliates

POOMPAT SAENGUDOMLERT, Ph.D. in Electrical Engineering and Computer Science, MIT, USA M.S. in Electrical Engineering and Computer Science, MIT, USA B.S.E. in Electrical Engineering, Princeton University, USA

Assistant Professor School of Engineering and Technology [*Areas of Communication Theory; Optical networks; Resource Allocation Problems and Array Processing*]

TEERAPAT SANGUANKOTCHAKORN, D.Eng in Information Processing, Tokyo Institute of Technology, Japan. M.Eng in Information Processing, Tokyo Institute of Technology, Japan. Certificate in Japanese Language, Osaka University of Foreign Study, Japan. B.Eng. in Electrical Engineering, Chulalongkorn University, Thailand.

Associate Professor School of Engineering and Technology [*Digital Signal Processing; Routing Algorithm in the network such as IP and MPLS network; High Speed network and IP-based multimedia applications*]

Adjunct Researchers

PANITA PONGPAIBOON, Ph.D. in Electrical and Computer Engineering, Carnegie Mellon University Master of Science in Electrical Engineering, Stanford University Bachelor of Science (with University Distinction) in Electrical Engineering, Stanford University

Researcher National Electronics and Computer Technology Center (NECTEC) [*Optical network management; IP-overoptical networking; Survivable and fault-tolerant networks; Network measurement; Traffic classification; IPv6; Mobile IP and Intelligent transport system*]

SURAT LERTLUM, Doctor of Technical Science in Computer Science, Asian Institute of Technology (AIT), Thailand, Master of Science in Computer Science, The George Washington University, Washington D.C., U.S.A., Bachelor of Science in Computer Science Engineering, Norwich University, Northfield, Vermont, U.S.A.

Research Scientist

Chulachomklao Royal Military Academy [*Low-resolution (NOAA AVHRR) forest classification includes thermal band; Highresolution (Landsat TM) forest classification includes thermal band; Multiresolution forest classification includes thermal band; Object-Oriented data model for multi-resolution / multitemporal remote sensing and GIS data sets*]

Short-term Visiting Researcher

ANIS LAOUTI, HIPERCOM/INRIA and **Assistant Professor**, TelecomSud, France
 [*Mobile Ad Hoc Network, Peer-to-Peer system*]

HAJIME TAZAKI, Jun Murai Laboratory Keio University and WIDE Project

[*IP routing architecture for mobility environment: IP Mobility architecture*]

Research Staff

KHANDAKAR RASHEDUL AREFIN, Master of Engineering in Information and Communication Technologies (ICT), Asian Institute of Technology, Thailand, Bachelor of Engineering in Computer Science and Engineering, Khulna University of Engineering and Technology, Khulna, Bangladesh.

Research Associate [*Mobile Ad Hoc Network*]

PUJAN SRIVASTAVA, Master of Technology (Information Technology), Indian Institute of Information Technology, Bachelor of

Engineering (Electronics & Communication) Agra University
Research Associate [*M-learning, Multimedia Communication*]

8.6 Grants and Sponsored Research Completed in 2010

AP Star Retreat Secretariat 2010

Duration: 01 Feb 10 - 31 Dec 10
 Project Investigator(s): Kanchana Kanchanasut
 Sponsor: APIA-APRICOT
 Total Contracted Amount (THB): 250,000

Asian Internet engineering Conference 2009

Duration: 01 Jul 09 - 31 Mar 10
 Project Investigator(s): Kanchana Kanchanasut
 Sponsor: Multi donors
 Total Contracted Amount (THB): 1,000,000

Epidemic Protocol for Car Talk

Duration: 01 Aug 09 - 30 Sep 10
 Project Investigator(s): Kanchana Kanchanasut, Teerapat Sanguankotchakorn
 Sponsor: National Electronics and Computer Technology Center, Thailand
 Total Contracted Amount (THB): 1,970,000

ICT Policy fo National University of Laos

Duration: 30 Jun 07 - 30 Jun 10
 Project Investigator(s): Kanchana Kanchanasut, Wit Hmone Tin Latt
 Sponsor: Swedish International Development Agency
 Total Contracted Amount (THB): 2,201,308

IT Training for National University of Laos (NUOL)

Duration: 1 Jun 07 – 31 Dec 10
 Project Investigator(s): Kanchana Kanchanasut
 Sponsor: Swedish International Development Agency
 Total Contracted Amount (THB): 3,063,745

The TEIN 3 Human Resource Program for 2010

Duration: 01 Dec 09 - 01 Dec 10
 Project Investigator(s): Kanchana Kanchanasut
 Sponsor: Multi donors
 Total Contracted Amount (THB): 2,000,000

UniChannel: Distance Education Infrastructure on UniNet

Duration: 01 Aug 08 - 30 Sep 10
 Project Investigator(s): Kanchana Kanchanasut
 Sponsor: Researchers/engineers
 Total Contracted Amount (THB): 2,000,000

8.7 On-going Grants and Sponsored Research

Asian Internet Engineering Conference 2010

Duration: 15 Dec 09 - 15 Mar 11
 Project Investigator(s): Kanchana Kanchanasut
 Sponsor: Multi donors
 Total Contracted Amount (THB): 900,000

CanalAVIST (Initial Phase)

Duration: 01 Dec 07 - 31 Dec 11
 Project Investigator(s): Kanchana Kanchanasut
 Sponsor: DANTE
 Total Contracted Amount (THB): 729,440

Development of Emergency Networks Training and Tools Kit

Duration: 01 Feb 09 - 31 Jan 11
 Project Investigator(s): Kanchana Kanchanasut
 Sponsor: ISIF Asia
 Total Contracted Amount (THB): 990,000

InterLab Trainings 2010

Duration: 01 Apr 10 - 01 Jan 11
 Project Investigator(s): Kanchana Kanchanasut
 Sponsor: Multi donors
 Total Contracted Amount (THB): 1,500,000

TEIN3 Human Resource program for 2011

Duration: 01 Dec 10 - 31 Dec 11
 Project Investigator(s): Kanchana Kanchanasut
 Sponsor: TEIN3/DANTE
 Total Contracted Amount (THB): 1,200,000

UniChannel: Distance Education Infrastructure on UniNet-Phase II

Duration: 01 Aug 10 - 31 Dec 11
 Project Investigator(s): Kanchana Kanchanasut
 Sponsor: UniNet (MOE/RTG)
 Total Contracted Amount (THB): 2,000,000

8.8 Publications

International Journal Article with Impact factor

Tazaki H., Van Meter R., Ryuji Wakikawa, Wongsardsakul T., Kanchana Kanchanasut. MANEMO routing in practice: Protocol selection, expected performance, and experimental evaluation. IEICE Transactions on Communications, 8(E93-B) 0-0, 2010.

Chapter 9: AIT – VIETNAM

9.1 Introduction

Asian Institute of Technology-Vietnam (AIT-VN) was established in 1993 under the agreement between the Government of Vietnam and AIT. Asian Institute of Technology-Vietnam takes pride in being the first international institution in Vietnam and the first Center of AIT out of its headquarters in Thailand.

Vision

Our vision is to become an unique and prestigious regional institution that offers responsive, work-relevant higher educational programs and outreach services for sustainable growth of Vietnam and the region as it integrates into global economy.

Mission

The mission of AITVN is to become a leading international educational institution of higher learning in Vietnam and the region.

9.2 Governance

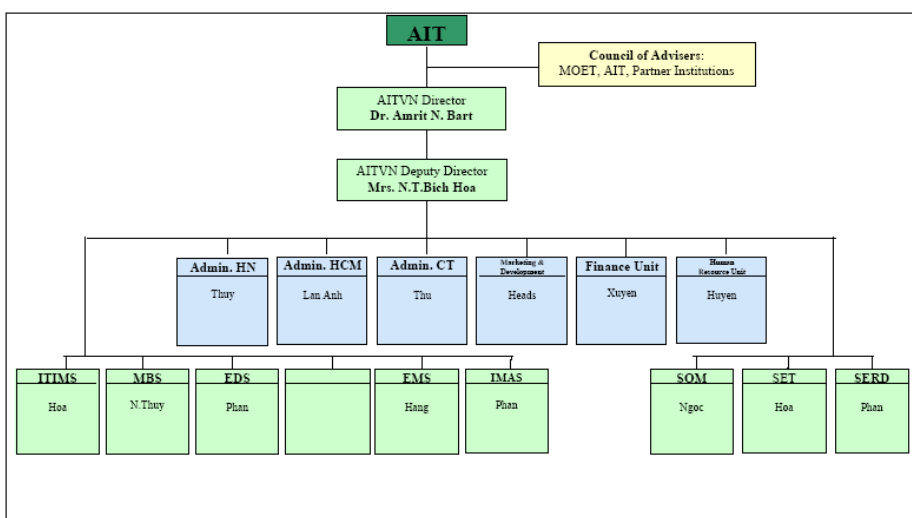

9.3 Services

AITVN offers academic services (in collaboration with AIT Schools and other universities of high reputation):

- Two-stage Masters, Doctors Programs
- Master Programs in Vietnam: Master of Business Administration Program for Executives; Doctor of Business Administration
- Professional Masters Programs
- International Masters of Advanced Studies

AITVN offers professional training programs:

- Short-term training courses specialized in Management and Business, Environment and Development, Language and Training, Advanced Technologies, etc.
- Customized training courses and cross-boarder study visits
- Seminars
- Outreach (consultancy) services

9.4 Fields of Postgraduate Education (On-Going)

- Information Technology (IT)
- Environment Technology Management (ETM)
- International Executive Master/Doctor of Business Administration (iEMBA/DBA)
- Industrial System Engineering Management (ISE)
- Telecommunications and ICT (TC and ICT)
- Construction, Engineering and Infrastructure Management (CEIM)
- Geo-Engineering and Management
- Geo-exploration and Petroleum Engineering
- Environmental Engineering & Management

9.5 Training Programs

Training for Professional Development

AITVN offers short training courses in 16 fields of professional skills nationwide. The programs are designed and conducted by AIT and AIT selected trainers, international experts and alumni. Newly acquired skills from those short courses are immediately applicable in improving performance at work.

Short-Term Training Courses

- Training Skills
- Interpersonal Communication Skills
- Language skills
- Administration and Secretarial
- Human Resource Development
- Management Development
- Marketing, Sales and Customer Services
- Supply Chain Management
- Industrial Engineering and Management

- Basic Management of Development Project
- Knowledge of Development Project Management
- Environmental and Natural Resources Management
- Urban Environmental Management
- Agribusiness Management
- Interpersonal Skills for Development Project Officers
- Finance Management

Tailor-made Courses

Upon request, AITVN organizes ‘tailor-made’ training courses and training combined with study tours for organizations in Vietnam and overseas. Training contents, venues and time are made to match the requirements of the recipient.

Training combined with study tour programs are in high demand. These programs have closely cooperated with universities and other institutions in Australia, Belgium, Bangladesh, China, Malaysia, Indonesia, Norway, Singapore, Taiwan and Switzerland.

9.6 Academic Programs in cooperation with AIT Schools in 2010

In cooperation with:

School of Management (SoM):

IEMBA Program Vietnam

Duration: Aug-00 - 31-Dec-09
 Project Investigator Frederic William Swierczek
 Sponsor AIT Operation
 Total Contracted Amount (THB) 36,000,000

School of Engineering & Technology (SET)

Professional Master in Project Management, Can Tho May 2010

Duration May-10 - May-11
 Project Investigator BHW Hadikusumo, Chotchai Charoenngam
 Sponsor Multi Donors
 Total Contracted Amount (USD) 241,000

School of Environment Resources & Development (SERD)

Professional Masters Program on Environment Engineering and Management

Duration: 2010-2012
 Project Investigator: Prof. Nguyen thi Kim Oanh
 Sponsor: VICEN, VINACOMIN, PVN, Corporation in Vietnam
 Total Contracted Amount (USD): 108,450

IHEID

International Executive Masters in Development Studies (IMAS)

Duration: 2003-2012
 Project Investigator: Daniel Fino
 Sponsor: SDC- Bern, Canton de Geneva
 Total Contracted Amount (USD): USD 130,000 (operation cost in Vietnam only)

9.7 On-going Grants and Sponsored Projects

In cooperation with:

SOM

DBA Program in HCMC 2007

Duration 1-Feb-07 - 31-Jan-14
 Project Investigator Indra Pandey, Nicholas Dimmit, Fredric Swierczek, Rian Beise-zee, Do Ba Khang, Sundar Venkatesh, Sununta Siengthai, Nazrul Islam, Lalit Johri, Illka Kauranen
 Sponsor Participants
 Total Contracted Amount (THB) 14,000,000

DBA Program in HCMC 2009

Duration 20-Jan-09 - 31-Dec-12
 Project Investigator Barbara Igel
 Sponsor Professional managers
 Total Contracted Amount (THB) 7,425,000

DBA Program in HN 2007

Duration 1-Jul-07 - 30-Jun-10
 Project Investigator Indra Pandey, Nicholas Dimmit, Fredric Swierczek, Do Ba Khang, Sundar Venkatesh, Sununta Siengthai, Nazrul Islam, Illka Kauranen
 Sponsor Participants
 Total Contracted Amount (THB) 12,250,000

International Executive MBA for Vietnam for Hanoi #11.1 & 11.2

Duration 1-Aug-10 - 31-Dec-11
 Project Investigator Do Ba Khang
 Sponsor Multi donors
 Total Contracted Amount (THB) 14,250,000

International Executive MBA for Vietnam for HCMC #7, VT#3

Duration 1-Aug-10- 31-Dec-11
 Project Investigator Do Ba Khang
 Sponsor Multi donors
 Total Contracted Amount (THB) 23,731,650

International Executive MBA for Vietnam for Hanoi #10.1 & 10.2

Duration 1-Aug-09 - 31-Dec-11
 Project Investigator Do Ba Khang
 Sponsor Multi donors
 Total Contracted Amount (THB) 14,875,005

International Executive MBA for Vietnam for HCMC

#6.1HCMC#6.2DN#3VT#2
 Duration 1-Aug-09 - 31-Dec-11
 Project Investigator Do Ba Khang
 Sponsor Multi donors
 Total Contracted Amount (THB) 46,627,384

International Executive MBA Vietnam: Hanoi

Duration 1-Aug-08 - 31-Dec-10
 Project Investigator Do Ba Khang
 Sponsor Multi donors
 Total Contracted Amount (THB) 21,250,008

International Executive MBA Vietnam: HCMC, DN, VT

Duration 1-Aug-08 - 31-Dec-10
 Project Investigator Do Ba Khang
 Sponsor Multi-donors
 Total Contracted Amount (THB) 32,075,384

SET

Professional Master in Project Management, Hanoi August 2010

Duration 1-Sep-10 - 31-Dec-11
 Project Investigator BHW Hadikusumo, Chotchai Charoenngam
 Sponsor PetroVietnam and Corporations in Vietnam
 Total Contracted Amount (USD) 162,950

Professional Master in Project Management, HCMC August 2010 _ Class A

Duration 1-Sep-10 - 31-Dec-11
 Project Investigator BHW Hadikusumo, Chotchai Charoenngam
 Sponsor PetroVietnam and Corporations in Vietnam
 Total Contracted Amount (USD) 241,192

Professional Master in Project Management, HCMC August 2010 _ Class B

Duration 1-Sep-10 - 31-Dec-11
 Project Investigator BHW Hadikusumo, Chotchai Charoenngam

Sponsor PetroVietnam and Corporations in Vietnam
Total Contracted Amount (USD) 220,300

Professional Master in Geo-Engineering and Management, HCMC August 2010

Duration 1-Sep-10 - 31-Dec-11
Project Investigator Pham Huy Giao
Sponsor Multi Donors
Total Contracted Amount (USD) 124,150

Professional Masters Degree Program in IE&M, HCMC Jan 2011

Duration Jan-11 - May-12
Project Investigator: Vorats Kachivichyanukul, Huynh Trung Luong, Eric Bohez, Pisut Koomsap
Sponsor: Multi donors
Total Contracted Amount (USD) 120,500

Professional Masters in Geoexploration & Petroleum Geoengineering, HCMC August 2010

Duration 1-Sep-10 - 31-Dec-11
Project Investigator Pham Huy Giao, Noppadol Phien Wej
Sponsor Oil and Gas Companies, Vietnam
Total Contracted Amount (USD) 119,821

SERD

Professional Masters Program on Environment Engineering and Management

Duration: 2010-2012
Project Investigator: Prof. Nguyen thi Kim Oanh
Sponsor: VICEN, VINACOMIN, PVN, Corporation in Vietnam
Total Contracted Amount (USD) : 108,450

IHEID

International Executive Masters in Development Studies (IMAS)

Duration: 2003-2012
Project Investigator: Daniel Fino
Sponsor: SDC- Bern, Canton de Geneva
Total Contracted Amount (USD) : USD 130,000 (operation cost in Vietnam only)

9.8 Short term Courses Completed in 2010

By Education Management Section (EMS)

Advanced Interpreting Skills for GTZ

Duration: 23-28 August, 2010
Total Amount (USD): 6,451

AIT Test

Duration: 29 June, 2010
Total Amount (USD): 75

AIT Test

Duration: 27 July, 2010
Total Amount (USD): 75

Bridging E Program for EVN & PV EMBA Candidates sponsored by NEC

Duration: 21 June – 13 September, 2010
Total Amount (USD): 16,577

Bridging for SET in Hanoi

Duration: 21 June – 10 August, 2010
Total Amount (USD): 4,500

Bridging Program for Post-Graduate Study for EEM Candidates

Duration: 20 March - 18 April, 2010
Total Amount (USD): 3,810

BTOT for EM1

Duration: 25 – 29 October, 2010
Total Amount (USD): 9,480

Comprehensive English Skills for Cuu Long JOC

Duration: 14,15,20,21 October, 2010
Total Amount (USD): 4,800

ECS for Multi-cultural Working Environment

Duration: 23 – 25 November, 2010
Total Amount (USD): 2,800

EM1 Revision for VPEG

Duration: 19 - 23 July, 2010
Total Amount (USD): 5,400

EMBA Bridging Ha Tien 1

Duration: 16 November, 2009 - 8 February, 2010
Total Amount (USD): 4,830

English Business Writing Skills for CapitaLand

Duration: 19-20 August, 2010
Total Amount (USD): 1,904

English Communication Skills (ECS) Ha Tien 1

Duration: 16 November, 2009 - March, 2010
Total Amount (USD): 4,830

English Test for Embassy of Sweden

Duration: 28 January, 2010
Total Amount (USD): 165

English Test for Embassy of Sweden

Duration: 15 April, 2010
Total Amount (USD): 33

English Test for Embassy of Sweden

Duration: 27 October, 2010
Total Amount (USD): 90

English Test for Embassy of Sweden

Duration: 23 & 30 November, 2010
Total Amount (USD): 330

English Skills for Interpreters (OPEN)

Duration: 14 - 19 June, 2010
Total Amount (USD): 5,400

Fee for organising English test for VICEM

Duration: 18 May, 2010
Total Amount (USD): 410

Intermediate English Communication Skills for Vicem

Duration: 15 January – June, 2010
Total Amount (USD): 22,827

Introduction to Vietnamese and Vietnamese history and culture for Macquarie university volunteers

Duration: 29 June, 9 July & 13 July
Total Amount (USD): 770

Management of Training

Duration: 20 – 22 September, 2010
Total Amount (USD): 2,051

Organising English Test for EVN on 13 July

Duration: 13 July, 2010
Total Amount (USD): 355

Professional Working Skills for Panasonic

Duration: 10 December, 2010
Total Amount (USD): 1,100

Upgrading English for MPM Master Studies in HCMC

Duration: 18 December, 2009 - 3 April, 2010
Total Amount (USD): 5,400

Upgrading English Skills for Post-Graduate Study for EVN & PV EMBA Candidates sponsored by NEC

Duration: 19 April - 17 July, 2010
Total Amount: USD 7,520

Upgrading English Skills for Post-Graduate Studies for MPM Students in Can Tho

Duration: 15 March - 28 April, 2010
Total Amount (USD): 3,600

By Environment & Development Section

Application of GIS in Environment Planning and Management- Advanced Revenue Center Code

Duration: October 2010- December 2010
Total Amount (USD): 5,653

Basic Facilitation and Report for AF Workshops

Duration: Jan – March 2010
Total Amount (USD): 5,790

Basic statistics - VBL

Duration: 28 June- 03 July 2010
Total Amount (USD): 5,500

Bioforsk-AIT Vietnam Workshop on Climate Change

Duration: 29 September 2010
Total Amount (USD): 5,800

Budgeting and Financial Management of Development Projects

Duration:12-16 July 2010
Total Amount (USD): 3,500

Capacity building for conducting environment education and communication program on raising the awareness of energy efficiency and saving for Holcim Vietnam

Duration: 15 September – 15 December 2010
Total Amount (USD): 2,300

Climate change impact assessment - ENDA

Duration: 27-29 September 2010
Total Amount (USD): 3,360

Climate Impact Assessment

Duration: 28 June- 30 July 2010
Total Amount (USD): 6,000

Community Development- Action Aid International Vietnam

Duration: 04 days ,10 June 2010
Total Amount (USD): 2,840

Consultation workshop on AIT- SIDA scholarship

Duration: 09 July- 30 August 2010
Total Amount (USD): 2,990

Heating in Brewery System- VBL

Duration: 07 -09 June 2010
Total Amount (USD): 3,000

Integrated Environmental Management in Coastal Industrial and Urban Areas- PCDA

Duration:22-25 June 2010
Total Amount (USD): 5,613

Integration of Environmental Management and Cleaner Production Aspects into Environmental Inspection of Industrial Enterprises - Denmark

Duration: 22-25 November 2010
Total Amount (USD): 2,867

International Negotiation - ADB

Duration: 01 September – 01 December 2010
Total Amount (USD): 47,880

Refresher course on Policy Advocacy- the Asia Foundation

Duration: December 2009 - 31 Mar 2010
Total Amount (USD): 3,400

Solid Waste Treatment-CSEED

Duration: 20 August- 30 September 2010
Total Amount (USD): 1,800

Study on Investment Conditions associated with RE sector in Vietnam – FAO- RAP

Duration: June 2010
Total Amount (USD): 16,000

Supersession-follow-up Report Writing- 135 Quang Ngai

Duration: 12-16 July 2010
Total Amount (USD): 4,200

Training courses on ToT- Department of Veterinary

Duration: 13-15 September, 23-24 September 2010
Total Amount (USD): 10,000

Visioning and action planning for Vietnam Public Libraries-The Asian Foundation

Duration: 8 Jan – 31 Mar 2010
Total Amount (USD): 5,790

By Management Business Section

Advanced Human Resource Management for NAV

Duration 14-16 September 2010
Total Contracted Amount (USD) 4,600

Banking Administration for BIDV (including 12 courses in Hanoi and HCMC)

Duration: 27 October – 12 November 2010

Total Contracted Amount (USD) 37,825

Capitaland training program (including 5 courses)

Duration
+ Presentation Skills: 18-21 May 2010
+ Work Planning and Time Management: 8-9 July 2010
+ Negotiation Skills: 17-18 Mar 2010
+ Business Writing:
+ Building a Professional Image: 19-20 May 2010
Total Contracted Amount (USD) 14,450

COLENGO Training Program (2 courses)

Duration
+ Project Circle Management: 17-18 December 2010
+ Facilitation Skills: 27-28 December 2010
Total Contracted Amount (USD) 4,820

Eurowindow training program in Danang (Including 3 courses on Professional Selling Skills)

Duration 16-21 September 2010
Total Contracted Amount (USD) 7,200

Eurowindow training program in Hanoi; Including 3 courses on Professional Selling Skills

Duration 22-28 September 2010
Total Contracted Amount (USD) 7,200

Finance Management for NAV

Duration: 19-21 October 2010
Total Contracted Amount (USD) 1,400

Human Resource Management

Duration 6-11 June 2010
Total Amount (USD) 3500

Management and Training Development

Duration 27-30 September 2010
Total Amount (USD) 2,400

Office Admin

Duration: 6-9 July 2010
Total Amount (USD) 4,400

Office Finance for CL JOC

Duration: 13-14 May 2010
Total Contracted Amount (USD): 2,700

Oil and Gas for CL JOC (2 courses)

Duration: 1-3 December and 5-7 December
Total Contracted Amount (USD) 8,500

Presentation Skills for CL JOC

Duration: 14-15 September 2010 and 3-4 November 2010
Total Contracted Amount (USD) 8,500

Project Management for CL JOC

Duration
Total Contracted Amount (USD) 4,000

Project Management for DCE

Duration: 16 – 19 August 2010
Total Contracted Amount (USD) 3,800

Strategic Planning and Implementing for Community Health Care for Save the Children

Duration: 14-19 June 2010
Total Contracted Amount (USD) 10,746

Work Planning and Time Management

Duration 23-24 September 2010
Total Amount (USD) 2,000

By Information and Technology and Industrial Management Section (ITIMS)**Aggregate Planning**

Duration: 6 July 2010
Total Amount (USD): 1,200

Contract writing and conflicts resolutions skills

Duration: 18 – 20 June 2010
Total Amount (USD): 2,060

Data analysis and Presentation using Excel

Duration: 28 – 30 May 2010
Total Amount (USD): 1,680

Data analysis and Presentation using Excel

Duration: 14 – 16 July 2010
Total Contracted Amount (USD): 1,800

Improve Business Management for Top Management of VICEM

Duration: Oct – Dec 2010
Total Contracted Amount (USD): 35,579

Maintenance Management Advance

Duration: 28 – 29 October 2010
Total Amount (USD): 2,150

Management Skills for Production Supervisors

Duration: 10 August – 30 September 2010
Total Contracted Amount (USD): 1,000

Material Inventory Management

Duration: 3 – 5 June 2010
Total Amount (USD): 1,860

Production and Operations Management

Duration: 2 – 4 June 2010
Total Contracted Amount (USD): 3,694

Production and Operations Management

Duration: 27 – 29 September 2010
Total Contracted Amount (USD): 3,693

Spare-parts Inventory Management

Duration: 11 – 12 September 2010
Total Contracted Amount (USD): 1,000

Statistic Techniques for Sampling test and Quality control - HABECO

Duration: 9 – 12 December 2010
Total Amount (USD): 5,088

Training cum study visit: Planning and Implementation of Community markets and market connecting roads

Duration: 31 July – 9 August 2010
Total Amount (USD): 20,000

Training cum Study visit: Urban Environmental Management & Application of ICT

Duration: 19 April – 3 May 2010
Total Contracted Amount (USD): 55,460

Training cum Study visit: Urban Environmental Management & Application of ICT

Duration: 9 – 24 May 2010
Total Contracted Amount (USD): 55,460

Training cum Study visit: Urban Environmental Management & Application of ICT

Duration: 29 May – 14 June 2010
Total Amount (USD): 61,500

Warehouse & Distribution Management

Duration: 17 – 18 May 2010
Total Amount (USD): 2,520

Warehouse Management & Control

Duration: 5 – 7 May 2010
Total Contracted Amount (USD): 1,800

Warehouse Management & Control

Duration: 23 – 25 June 2010
Total Contracted Amount (USD): 2,604

9.9 On-going Activities

By Environment & Development Section**Effectively cooperating tools for EM including EE, EA, ER and EMS**

Duration: Nov 2010- Feb 2011
Total Contracted Amount (USD) 5,122.7

Integrating CP and EM into Environmental Inspection- CPI

Duration: 2010- 2011
Total Contracted Amount (USD): 21,082

Integration of Environmental Management and Cleaner Production Aspects into Environmental Inspection of Industrial Enterprises

Duration: October 2010- September 2011
Total Contracted Amount (USD) 18,026

Project planning and management

Duration: January 2010 – January 2011
Total Contracted Amount (USD) 7,000

Technical Guidelines for Provincial Assessment of Climate Change Vulnerabilities

Duration: June 2010- October 2011
Total Contracted Amount (USD) 22,186

Training cum Study tour on livelihood development for NETZ

Duration: 01 Nov 2010- 20 Jan 2011
Total Amount (USD): 6,905.7

By Management Business Section**Advocacy for LMPA**

Duration: 13-15 May 2011
Total Contracted Amount (USD) 9,165

Banking Administration for BIDV (including 14 courses in Hanoi and HCMC)

Duration: 13 June – 12 July 2011
Total Contracted Amount (USD) 19,000

BIDV Training Program for Experts

Duration: 21-30 March, 4-8 April and 15-19 April 2011
Total Contracted Amount (USD) 45,454

Budgeting for Eurowindow

Duration: 5-6 January 2011
Total Contracted Amount (USD) 2,400

Contract Drafting and Negotiation Skills for CL JOC

Duration: 5-7 January 2011
Total Contracted Amount (USD) 21,600

Eurowindow Training Program for Middle Management

Duration: 16-19 May and 23-26 June 2011
Total Contracted Amount (USD) 14,400

Leadership Skills for CNC VINA

Duration: 13 May 2011
Total Contracted Amount (USD) 1,722

Leadership Skills for LMPA

Duration: 14-16 March 2011
Total Contracted Amount (USD) 7,750

PVPower Training Program (2 courses on Leadership Skills)

Duration: 18-19 March and 25-26 March 2011
Total Contracted Amount (USD) 6,004

Risk Management for BIDV

Duration: 13-17 January 2011
Total Contracted Amount (USD) 4,300

Soft Skills for VN Stockmart

Duration: 26-27 March 2011
Total Contracted Amount (USD) 2,240

Chapter 10: CENTERS OF EXCELLENCE AND OUTREACH

10.1: CENTER OF EXCELLENCE ON SUSTAINABLE DEVELOPMENT IN THE CONTEXT OF CLIMATE CHANGE (Coe SDCC)

10.1.1 Profile

AIT's Strategic Plan 2013 emphasizes the consolidation of research efforts and creation of a niche that will harness the institute's range of network, experience and expertise. Sustainable development has been central to AIT's research and development efforts since its inception. The Institute has responded rapidly to the new challenges the region faces. Climate change is a global challenge and concerted trans-disciplinary efforts are required to develop new adaptation and mitigation strategies which will provide local communities more resilience while leading towards a more sustainable society. The Asian Institute of Technology is committed to work towards this by forming strong team, and networks and working in a collaborative manner with all stakeholders. The Institute continues to pursue its role as a leading center of knowledge production in the region.

Since its inception in September 2009, the Center of Excellence on Sustainable Development in the context of Climate Change (CoE SDCC) has been playing its role in supporting AIT's role as an institute working in climate change platform in the region through maximizing the institute's research resources as well as its broad network.

10.1.2 Mission

The mission of the AIT Center of Excellence in SDCC to consolidate the Institute's research efforts and broaden the networks and partnerships by providing a platform to discuss and launch shared initiatives and pool resources to effectively address issues and challenges in sustainable development and climate change.

The thematic research area aims to stimulate the formation of teams that merge knowledge, experience and networks. This approach will allow centralizing some support functions to research activities, but also aims at diversifying research teams to make better use of the width of experience at AIT.

The thematic research areas identified by AIT are:

1. Vulnerability and Disaster Risk Reduction
2. Water and Land Resources Management for Sustainable Production and Consumption
3. Urban and Rural Quality of Life and Sustainability
4. Low Carbon and Cleaner Production Technologies and Management
5. Business and Innovation Models for a Green Economy

10.1.3 Objectives

- Bring together thought-leaders, research groups and SDCC experts to reflect on future research, design action plans and agenda, and pool resources to face emerging issues and urgent themes in climate change adaptation and mitigation
- Consolidate the Institute's research efforts and partnerships by providing a platform to discuss AND LAUNCH shared initiatives with like-minded stakeholders and partners
- Strengthen AIT's role as regional hub of knowledge and experience in research and development in sustainable development and

climate change adaptation and mitigation

10.1.4 Facilities

SDCC is regulated by the AIT human resources rules and by AIT contracts. SDCC provides student assistantships based on the work needs and issues contracts to its short term consultants according to AIT standards and work requirements. SDCC is involved in working closely with AIT faculty, researchers, students and external partners according to the needs and requirements of the type of work / projects.

10.1.5 Activities Carried out in 2010

SDCC / AIT – France Network Program

In order to strengthen AIT and France common research strategy toward SDCC – Sustainable Development in the context of Climate Change, a regional program targeting young researchers interested in new collaborative projects was initiated which is based on the general theme of “*sustainable development and climate change*”, with a focus on *the development of the ASEAN region using multidisciplinary approaches*.

Objective:

To identify high-quality proposals for leading-edge research projects between research teams from AIT, France and ASEAN based institutions, particularly in the six thematic research areas identified by AIT for its new Center of Excellence on

Sustainable Development in the context of Climate Change.

In order to provide additional support to the selected projects and to use the necessary ties between Asian and French teams, the French Ministry of Foreign and European Affairs (MAEE), through the Regional Office for Cooperation, Embassy of France in Thailand, and its financial agreement for the year 2009 with the Asian Institute of Technology (AIT), decide to allocate partial scholarships for doctoral studies under a joint supervision scheme between AIT and a French institution. Joint supervision under French model enables a doctoral student to pursue his/her research work under the supervision of two institutions.

Current Status of the Program:

After a thorough evaluation from the Scientific Committee and the final decision from the Steering Committee of the regional program "SDCC / AIT - France Network" co-funded and implemented in partnership by AIT and the French regional cooperation at AIT (French Ministry of Foreign and European Affairs), we are very pleased to announce the selected proposals:

Assessment of Co-Benefits on Air Quality and Climate Resulted from Various Control Strategies in Southeast Asia

PI: Prof. N.T. Kim Oanh
Partners: Royal University of Phnom Penh, Cambodia Laboratoire des Sciences du Climat et de l'Environnement, Gif/Yvette, France Institut de Combustion, Aérothermique, Réactivité et Environnement (ICARE), France

LICORICE (Life Cycle Assessment of Cotton and Rice)

PI: Dr. Sylvain Perret
Partners: Kasetsart University, Thailand, King Mongkut's University of Technology, Thonburi, Thailand, Vietnam National University of

Sciences, Hanoi, Vietnam, CIRAD - UMR Qualisud & ELSA, Montpellier, France, CIRAD - UMR G-Eau- IRRRI Vietnam, Vietnam National University, Hanoi, Vietnam, Hanoi University of Agriculture, Vietnam, CIRAD - UMR Hortsys - ELSA, Montpellier, France.

Production of Bio-ethanol and Biomaterials from Oil Palm Biomass: A study of Feedstock Sustainability, Technological Efficiency and Social Applicability.

PI: Prof. Sudip K. Rakshit.
Partners: University of Sains Malaysia, Penang, Malaysia, Nancy University, France, INRA-Plate-forme de Prédevelopment en Biotechnologie, France, ENSTIB, Epinal, France.

Sustainability Issues Due to Coal Ash From Coal Fired Power Plants.

PI: Prof. Ajit Annachhatre
Partners: Chiang Mai University, Thailand, De La Salle University, Manila, the Philippines, Université Paris-Est Marne-la-Vallée, France.

Special Cases:

Low Carbon Cities: Learning from the Experiences in France.

PI: Prof. Sivanappan Kumar
Partner: ADEME

Asia Technology Needs Assessment (TNA) Implementation Project

The UNEP Risoe Centre (URC), Denmark has engaged CoE SDCC in working as Regional Center of its Technology Needs Assessment (TNA) project in developing Asian countries. As regional centre, CoE SDCC serves as the focal point in giving any technical support and capacity building for the participant countries respectively. This is part of a worldwide effort by the Global Environment Facility (GEF) to implement the TNA project, which is designed to support 35 to 45 countries within the framework of the UNFCCC. The project is being implemented in two rounds, with 5

to 6 countries in Asia (Thailand, Indonesia, Vietnam, Cambodia, Bangladesh, and Georgia) in the first round and another 5 to 6 countries in Asia to be included in the second round. The objective of the TNA project is to assist participant developing country identify and analyze priority technology needs, which can form the basis for a portfolio of environmentally sound technology (EST) projects and programs to facilitate the transfer of, and access to, the ESTs and know-how in the implementation of Article 4.5 of the UNFCCC Convention.

The project is also aimed at strengthening the networking of the regional centers in different parts of the world and enhances their cooperation with countries through their role as regional knowledge hub for supporting relevant activities in the region. The capacity built through the project can be useful far beyond the duration of this project in this important area of technology transfer. This is because many more activities can be expected to be initiated by various donors, governments, and other agencies in all the regions. Prof. S.K. Rakshit and Prof. S. Kumar will serve as the focal point for the Regional Centre in SDCC, AIT in adaptation and mitigation respectively.

Current status of the project

1. A first Regional Capacity Building Workshop for round one countries in Asia has been conducted in Bangkok from 15-17 September 2010. The aim was to familiarize the country TNA coordinators, national consultant, and experts in selecting technologies/strategies for Mitigation & Adaptation, conducting the stakeholder engagement and other technical support knowledge they might need for TNA implementation. Participants included country participants from the five first

round countries, UNEP, GEF, UNDP and AIT.

2. Second regional capacity building Workshop in Asia For Technology Needs Assessment Project has been conducted in Bangkok from 18-21 January 2011. The workshop aimed to provide inputs / training to the National Consultants /Experts working on the project in the countries in:

1. Identifying barriers and inefficiencies by using market mapping and other tools;
2. Identifying activities aimed to overcome the identified barriers and inefficiencies;
3. Identifying activities to accelerate technology deployment; and
4. Developing TAPs describing activities and enabling frameworks to overcome the barriers and facilitate

the transfer, adoption, and diffusion of selected technologies in the participant countries.

Thailand's Institutional and Policy Landscape on Climate Change Mitigation

Aiming to provide an assessment of gaps between needs for effective implementation of National Strategy on Climate Change prepared by Royal Thai Government and existing supports from all UN agencies, government's own plans, and support from other international non-governmental agencies is considered as first step to identify possible areas to develop joint programme and activities to support government, UNEP as the Secretariat for the Joint Team on Climate Change has engaged AIT in conducting a thorough research on Thailand's institutional and policy landscape on climate change mitigation.

The study is designed to map the role of stakeholders: who (UN agencies, Government and non-government) is doing what in the context of climate change mitigation including technology transfer, what is the policy and legislative environment, what are the mitigation strategies and action plans of the government and what gaps exist and how can the UN agencies help to fill in the gaps.

Current Status: *Ongoing*

10.1.6 Plans for 2011

- Continuing the current research project.
- Approaching new research projects related to SDCC mandate.

10.2: ASEAN REGIONAL CENTER OF EXCELLENCE ON MILLENNIUM DEVELOPMENT GOALS (ARCMDG)

10.2.1 Introduction

Following the ASEAN Regional Roundtable on MDGs “ECOSOC’s Promotion and Achievement of Millennium Development Goals through Education and Outreach” on 24-25 March 2008 held at Asian Institute of Technology (AIT), Bangkok, and through declaration made by the participants, the ASEAN Regional Center of Excellence on MDGs was created to promote, educate and train on MDGs throughout the region in close collaboration with actors in the field.

ARCMDG has been welcomed by the UN Secretary-General as the world’s first Regional Center of Excellence on MDGs following its establishment and functioning at AIT. The center was established and made functional since 1 May 2008 with the appointment of Dr. Jayant Kumar Routray, Professor of Regional and Rural Development Planning as Director to formalize the initial process and follow the activities as mandated through the mentioned declaration. Mission

10.2.2 Mission

The mission of the ARCMDG is to contribute, catalyze and deliver knowledge management services, in order to support the implementation and timely attainment of the MDGs in the ASEAN region and beyond. The aim is pursued through its capacity building, education and research programs, coupled with consulting and advisory services, networking and partnership building activities in close collaboration with national, regional and international organizations inclusive of civil societies and non-governmental organizations.

Moreover, together with AIT outstanding academic and professional training programmes, ARCMDG facilitates

strengthening of capacity buildings of officials of governments and organizations. The courses offered are designed for skilled professionals in development field and are presented by knowledgeable and experienced trainers.

10.2.3 Goals

ARCMDG goals are:

1. To optimize the knowledge management on all aspects of MDGs in ASEAN and elsewhere.
2. To facilitate the identification, development, sharing, implementation of good practices in MDGs governance and in MDGs programme execution.
3. To facilitate and institutionalize trend analysis and transparent monitoring of MDG achievements and failures.

10.2.4 Objectives

In response to the declaration of the ASEAN Regional Roundtable and following the TOR of the center, the objectives are as follows:

1. To **popularize** the MDGs, by spreading, disseminating, and propagating information on MDGs, starting with 4 Goals: Goal 1, Eradication of Extreme Poverty and Hunger; Goal 3, Promotion of Gender Equality and Empowerment of Women; Goal 7, Ensuring Environmental Sustainability; and Goal 8, Global Partnership for Development, throughout the ASEAN Region.
2. To **mobilize** educational environments for spreading, teaching and learning about MDGs.
3. To **develop** and offer pedagogical modules, educational materials and

tools for MDGs training in government and academic institutions, civil society, NGOs and private sector, complementing similar initiatives by other Centers of Excellence on MDGs operating elsewhere in the world.

4. To **help** establish National Centers of Excellence, starting with the ASEAN Region and to exchange information and competencies on MDGs between the Centers of Excellence.
5. To **stress** the promotion of gender equality and empowerment of women as a cross-cutting issue of all MDGs, viewed within the human rights perspective and linked to the MDGs.
6. To **establish** a bank of trainers and of networks of experts in MDGs and to train the trainers and professionals involved with MDGs.
7. To **conduct** research of psycho-pedagogical impact for the spread of MDGs.
8. To **collaborate** and cooperate with internal units of AIT and external institutions, countries and regional organizations, including UN, NGOs, civil societies engaged in MDGs focused activities.
9. To **organize** seminars of experts and to make publications, press relations on MDGs.
10. To **harmonize** the internal AIT initiatives on Gender, MDGs and Corporate Social Responsibility (CSR).
11. To **document** research on related themes of the MDGs and to disseminate the impacts of MDGs.
12. To **coordinate** and **cooperate** with Schools, Fields of Study, and AIT Extension for the integration of MDGs into the core curricula.

10.2.5 Governance

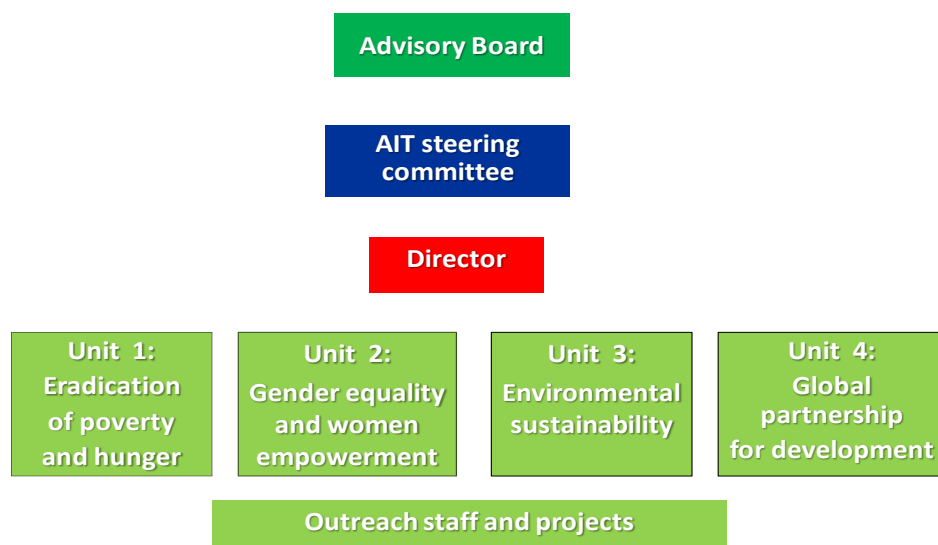

facilitate self-evaluation of MDGs trends and an online network to facilitate the sharing of good practices and the understanding of the required improvements.

ARCMDG cooperates closely with other AIT outreach programmes, such as the AIT Yunus Centre, the CSR Asia Center, UNAIT, the Center on sustainable development in the context of Climate Change (SDCC) as well as with the AIT Centers of Excellence, partners and sponsors.

AIT regular academic courses in the area of Millennium Development Goals include the following:

MDG 1: Eradicate Extreme Poverty and Hunger

- D60.01 - Development Economics;
- IN00.21 - Sustainable Development;
- ED77.01 - Rural and Regional Development;
- ED77.05 - Rural-Urban Relations;
- ED77.08 - Agricultural Development Planning;
- ED77.13 - Rural-Regional Planning Workshop;
- ED77.14 - Community Development Planning.

MDG 3: Promote Gender Equality and Empower Women

- ED75.01 - Gender and Development;
- ED75.02 - Society, Technology and Health;
- ED 75.03 - Gender, Enterprise and Organizations;
- ED 75.04 - Gender, Rural Livelihoods and Sustainable Development;
- ED 75.05 - Gender, Technology and Economic Development;
- ED 75.06 - Gender, Culture and Human Development;
- ED 75.07 - Gender Analysis and Gender-responsive Development Planning;
- ED 75.08 - New Technology, Industrialization and Gender;
- ED 75.09 - Transforming Gender Ideologies in Society;

10.2.6 Staff

All ARCMDG staff is regulated by the AIT human resources rules and by AIT contracts. ARCMDG accepts short term internships and issues contracts to its short term consultants according to AIT standards. Publications

10.2.7 Organization of Work

The work of ARCMDG is managed by a Director, under the guidance of a Steering Committee composed of AIT faculty, and of an Advisory Board composed of eminent personalities. ARCMDG is presently organized in four units of work plus the director's office. AIT provides administrative and management support and oversight to ARCMDG, including administrative services, finance, budget, human resources and other support services.

The four units of work are:

1. Eradication of extreme poverty and hunger
2. Gender equality and women empowerment
3. Environmental sustainability
4. Global partnership for development.

ARCMDG training and capacity building services are implemented as far as possible through the AIT Extension. ARCMDG outreach, applied research and policy facilitation work is done by ARCMDG staff in collaboration with partners.

10.2.8 Location and Facilities

ARCMDG is located at the AIT Campus in Pathumthani, near Bangkok, Thailand. The ARCMDG office facility is presently located at the AIT Conference Centre.

10.2.9 Courses and Services

ARCMDG provides a variety of services to the MDGs authorities and focal points in national governments, International organizations and International NGOs.

The major focus of ARCMDG activities is to accelerate and facilitate organizational changes and innovation, particularly at grass root level, to strengthen the result orientation of development operations, to guarantee the people empowerment in development deeds and to facilitate the localization of MDGs efforts.

The services planned for the future include a user friendly online facility to

- ED 75.10 - Gender, Urbanization and Urban Management;
- ED75.9002 - Selected Topic: New Technologies, Industrialization and Gender: Nature of globalization; gender, industrialization and technology;
- ED75.9003 - Selected Topic: Workshop on Gender, Environment & Development;
- ED75.9004 - Selected Topic: Gender Politics, Civil Society & Human Rights;
- ED75.9005 - Selected Topic: Gender, Migration and Human Trafficking in Asia.

MDG 7: Ensure Environmental Sustainability

- ED78.02 - Biological Processes;
- ED78.03 - Physico-Chemical Processes;
- ED78.04 - Aquatic Chemistr;
- ED78.05 - Waste Reduction and Recycling;
- ED78.06 - Air Pollution and Air Quality Management;
- ED78.07 - Solid Waste Management;
- ED78.08 - Environmental Quality Management;
- ED78.09 - Environmental Management and Ethics;
- ED78.10 - Environmental Health and Sanitation;
- ED78.11 - Integrated Life Science;
- ED78.12 - Principles of Toxicology;
- ED78.13 - Health, Development and Environment;
- ED78.14 - Membrane Technology in Water and Wastewater Treatment;
- ED78.15 - Design of Water Supply and Wastewater Systems;
- ED78.16 - Applied Microbiology and Laboratory;
- ED78.17 - Advanced Processes for Wastewater Treatment, Reuse and Recycle;
- ED78.18 - Toxic Organics and Trace Metals in Ecosystem;
- ED78.19 - Environmental Impact Assessment;
- ED78.20 - Industrial Waste Abatement and Management;
- ED78.21 - Water Quality Management;

- ED78.22 - Air Pollution Modeling and Applications;
- ED78.23 - Hazardous Waste Technology and Management;
- ED78.25 - Principles of Cleaner Production;
- ED78.27 - Environmental Toxicology;
- ED78.28 - Health/Environmental Risk and Impact Assessment;
- ED78.31 - Bioengineering and Environmental Health;
- ED78.9010 - Environmental Economics;
- ED79.01 - Urban Environmental Management Systems;
- ED79.03 - Urban Planning and the Built-Environment;
- ED79.04 - Environmental Science and Technology for Decision Makers;
- ED79.05 - Urbanization and Environmental Policy;
- ED79.06 - Environmental Auditing;
- ED79.07 - Disaster Management in Urban Environmental Planning;
- ED79.08 - Environmental Legislation;
- ED79.09 - Urban Environmental Design;
- ED79.10 - Urban Environmental Planning and Management Workshop;
- ED79.12 - Management of Urban Housing, Infrastructure and Service;
- ED79.13 - Strategic Environmental Assessment for Urban Development;
- ED79.14 - Governance and Urban Management;
- ED79.15 - Urban Economics and Finance;
- ED79.16 - Environmental Conflict Resolution and Mediation.

Other MDGs Courses planned for 2011 by AIT Extension

- Agri-Business Management
- Food Safety and Quality Management
- Sustainable Land Management and Extension Techniques
- Project Management
- Project Management, Monitoring and Evaluation
- Quality Assurance for Higher Education and Training Institutions
- Toxic and Hazardous Waste

- Management
- Urban Environmental Planning and Management
- Sustainable Sanitation System and Technology
- Management for Development Results
- Rural Entrepreneurship Development
- Urban Poverty Reduction
- Gender Mainstreaming into Plans
- Program and Legislation: Political & Electoral Process
- Organizational Changes to accelerate and localize MDG implementation

10.2.10 Activities Carried Out in 2010

Organizational and Policy Support

1. MDGs 6th Round Table in Danang, Vietnam, 22-23 April 2010;
2. In August 2010 a new Director was selected;
3. In September 2010 Dr. Sandro Calvani took office as new Director;
4. Former Director Prof. Jayant Routray continues to support ARCMDG Management as Head of Training;
5. A new Business Plan was drafted and circulated to Steering Committee ;
6. The new director initiated a wide consultation of perspective partners including AIT Excellence Centers, AIT Consulting, AIT Extension, ASEAN Secretariat, the World Economic Forum and various UN Bodies, in order to create an enabling environment for a partnership with other organizations to support policy making and Knowledge Management Services for MDGs acceleration;

7. International conference on Language, Education and the Millennium Development Goals, 9-11 November 2010;
8. Regional Workshop on the ASEAN Roadmap for the attainment of MDGs, 24-25 January 2011 in Bangkok, Thailand.
8. Training on Gender Mainstreaming and Equality with Focus on MDGs, 6-11 December 2010 for Afghanistan officials.
9. Training on Development Planning & Governance for Poverty Reduction, Thailand 24 January-9 February 2011 for India government officials.

Training

1. Seminar cum Study Tour Program on "Project Monitoring and Evaluation with Focused on Poverty Reduction and MDGs", 25-29 January 2010.
2. A workshop on "MDGs analysis and operational indicators for gender mainstreaming and equality" was held on 28-29 January 2010.
3. Capacity Building for Poverty Reduction Strategies, Government of India (Phase I), 1-12 March 2010, ARCMDC and GIC
4. Capacity Building for Poverty Reduction Strategies, Government of India (Phase II), 20- 02 April 2010, ARCMDC and GIC
5. Development of the training modules on gender mainstreaming and equality and pilot testing using existing research including UNIFEM materials on 9-17 August 2010
6. "Study Visit Program on Strategic Planning and Pro-Poor Growth", 3-10 October 2010 in Thailand and Indonesia
7. Senior Executive Training & Multi-Country Study visits on "Development Planning, Management & Governance" for Government of India Officials, 1-2 November 2010, jointly organized by GIC and ARCMDC, AIT.

UNIFEM Project

1. Training Workshop and Thematic Research on Gender Mainstreaming.
2. Thematic Research on "Livelihood Assets and Economic Empowerments of the Home based Women Workers" is in progress in five countries – Bangladesh, Cambodia, Malaysia, Thailand and Vietnam.

10.2.11 Plans for 2011 and Beyond

1. A fundamental challenge required for MDGs acceleration is **to re-design and re-focus the pro-poorness of development governance**. It is self-evident that the required technologies for sustainable development are now available and affordable. However, while there is a consensus on what should be done to attain the MDGs, there is too much fragmentation on who should lead the required organizational changes and how people should be empowered. People empowerment and localizing the attainment of MDGs could represent the great leap which can make up for the required difference.

The most important and safest foundation of sustainable growth is an **in-depth understanding of the ongoing development process** and, in particular, of its failures and success stories. Since ignorance and indifference should not be tolerated

either by governments or civil society and the people in every poor village or neighbourhood, a new sense of urgency must be introduced. Furthermore, **knowledge management** is an effective tool to identify practical tools and strategies to break out of the chronic poverty cycle.

For all these reasons, as soon as pluses and minuses of local MDGs attainment are identified, an organizational change should be agreed in order to adapt the implementation of sustainable development to the identified weaknesses and strengths.

The first step that ARCMDC aims to undertake in order to initiate the required adaptive changes in practicalities of sustainable development would be the analysis of the so called "**Socio-Economic Easy Determinants (SEED)**."

ARCMDC will conduct an **applied research** based on real cases occurred in ASEAN Countries. These researches will assess the major socio-economic determinants of chronic poverty in ASEAN as well as real success and failure stories where the trends of deprivation have been inverted or consolidated.

Particular attention will be devoted to the analysis of growing gaps of inequality in terms of gender, ethnicity, generations and economic status of the reviewed people.

As a **second step**, where appropriate, the applied research will review also the **core components of sufficiency economy**: moderation, reasonableness and resilience, including the underlying conditions of the applied developmental change such as excellence of knowledge management and consistency of focus on ethics and values.

The applied researches led by ARCMDC will then identify the

organizational changes required to facilitate a shift to “Dev 2”, i.e. a complete re-set of development activities where past policies have remained off-track.

2. In order to **realize this needed organizational change**, the Center will consider possibilities to create a blog and a new magazine, which will

be a good platform for gathering and sharing information. Such new tools, in fact, make key information and subject matters available and understandable to all concerned stakeholders. In addition, they represent an efficient catalyst to gather information and lead to a concrete sharing of experiences and good practices on localizing MDGs

3. ARCMDG will strive to **become a partner of various consortia of institutions put together to execute applied research and outreach management services** in the field of sustainable development.

10.3: CSR ASIA CENTER AT AIT (CSRACA)

10.3.1 Introduction

The CSR Asia Center at AIT (CSRACA) is a joint venture partnership between the Asian Institute of Technology (AIT) and CSR Asia, the leading provider of information, training, research and consultancy services on sustainable development practices and corporate social responsibility (CSR) in Asia. It brings together the strengths of the two founding organizations in pursuit of its vision of a dynamic, competitive business environment in Asia, in which the private sector is equipped to develop and implement innovative solutions for the challenging issues of sustainable development in a strategic and effective manner.

In line with AIT's commitment to the pursuit of sustainable development as a central part of its mission, AIT promotes an inclusive approach in line with the increasingly widely accepted perception that single sector solutions to development are likely to fail. All stakeholders, including the private sector, need to be proactively engaged to respond to key sustainability and development challenges such as climate change, poverty alleviation, and other development targets as defined in the Millennium Development Goals. CSR as an approach to driving private sector contributions to sustainable development and business solutions to a variety of global challenges is therefore an important issue area for AIT.

10.3.2 Background

In November 2008 AIT hosted CSR Asia's annual Summit that attracted more than 300 delegates from around the region. That marked a significant achievement in a partnership that had been developed more than a year previously. In the summer of 2007 a week-long Leadership Programme led by CSR Asia and supported by United Nations University (UNU) saw the first successful intensive

CSR programme mounted through AIT Extension.

Based on the sound foundation of a successful partnership between a well established and respected academic institution and the leading corporate social responsibility enterprise in Asia, the CSR Asia Center at AIT was established based on an agreement between AIT's President and CSR Asia's Chairman in 2009. It started its operations with the hire of a full-time director in January 2010. The agreement was formalized by the public signing of a Memorandum of Understanding, effective for three years from the date of signature, by both parties at the official launch of the Center in March 2010.

10.3.3 Mission

The mission of the CSR Asia Center at AIT is to

- Advance the development and implementation of effective and innovative sustainability solutions and CSR strategies for and by business; and
- Facilitate the development of supportive framework conditions for corporate social responsibility (CSR) and sustainable development.

10.3.4 CSR Asia – a strong partner for AIT

CSR Asia operates as a dynamic not-for-profit social enterprise with offices and partnerships across the Asia Pacific region. Established to promote sustainable development in Asia, CSR Asia advocates strategic approaches to corporate social responsibility and business solutions to global challenges to businesses and their stakeholders in the region and beyond and provides independent and cutting edge services and expert insight on CSR.

CSR Asia has an extensive network of companies, business associations, NGOs, and other organizations across the Asia Pacific region, many of which actively engage with CSR Asia on an ongoing basis through the CSR Asia Strategic Partnership Program (CASP).

CSR Asia has acted as a consultant to some of the world's leading brands and locally listed companies in Asia. It has undertaken research work for a number of United Nations and development agencies on a variety of issues related to the role of the private sector in sustainable development and business solutions to global challenges. CSR Asia has further delivered training to hundreds of managers and executives, from business and other organizations, engaged with thousands through a variety of events and knowledge exchange platforms, and delivers CSR intelligence to tens of thousands weekly through its newsletter and website.

10.3.5 Key Activities

As agreed in the Memorandum of Understanding between AIT and CSR Asia that establishes the CSR Asia Center at AIT, the key activities of the CSRACA are:

1. To offer executive education, training and capacity development for the private sector, national and local governments, NGOs and international organizations. The Center will facilitate knowledge and skills development for addressing general and sector-specific solutions in the area of CSR and sustainable development. Using its insight into best practices and principles, the Center will create state-of-the-art short courses for the future and current practitioners and policy-makers. Executive education courses will be designed to be stand-alone or build into a professional Master's degree qualification.

2. To provide consultancy services principally aimed at companies in Southeast Asia and South Asia where AIT has already established networks.
3. To carry out research into issues and trends relevant to CSR in Asia, focusing on and tracking the needs and aspirations of stakeholders and the private sector itself. The Center will bid for contract research from international organizations and the donor community based on the reputations already established by AIT and CSR Asia.
4. To participate in building ongoing dialogue leading to shared understandings of challenges and solutions for CSR among businesses, policy makers and civil society; and
5. Assisting with promoting each other's activities.

10.3.6 Key Objectives

The key objectives for the CSR Asia Center at AIT are:

- To create a platform for dialogue among the private sector as well as government agencies, international organizations, and civil society organizations to further innovation, partnerships, and creative solutions for the challenging issues of sustainable development
- To contribute to knowledge development about the effectiveness of different approaches used in the field of CSR, and the generation of innovative practices, methods, and policies
- To facilitate the generation of capacity for sustainable business, community development and partnerships with business for poverty alleviation and delivering on the other Millennium Development Goals

- To contribute to preparing the region for the impacts of climate change and harnessing the innovative capacity of the private sector to proactively contribute to mitigation efforts as well as to building adaptive capacity.
- To design and launch a flexible professional masters programme in CSR delivered in an executive style involving intensive modules and including an action research based thesis aimed at attracting part-time students wishing to increase their knowledge and skills in CSR

10.3.7 Governance and Staffing

Advisory structure

The CSRACA Director is supported through ongoing advice and guidance from key senior representatives of both AIT and CSR Asia:



Reporting structure and staff development

The CSRACA Director reports directly to the AIT President and the CSR Asia Chairman.

The CSRACA Director manages the CSRACA program, project, and admin team. Starting with the hire of the Director in January 2010, the Center has grown to three fulltime staff by the end of 2010. It is expected that the team will have grown to six by the end of 2011 in step with demand for services and increased income generation.

Internships and Student Assistantships

The CSRACA offered three summer internships of two months duration each to MBA candidates from AIT's School of Management and in addition contracted a Student Assistant for short term project support. It is expected that a similar number of internship opportunities will be available in 2011.

10.3.8 Profile of Services

Training and capacity building

Delivering knowledge and skills development for businesses and their stakeholders to address general and sector-specific solutions in the area of CSR and the role of the private sector in sustainable development

Consultancy

Specialized advisory services on CSR and sustainable business strategies, including CSR strategy development, sustainability reporting, benchmarking and gap analysis on CSR, stakeholder engagement, workshops, etc

Research

In-depth examinations of issues and trends relevant to CSR and business contributions to and partnerships with business for sustainable development in Asia with a Mekong sub-region focus; tracking the needs and aspirations of stakeholders and the private sector

Engagement

The Center facilitates on-going dialog on CSR approaches, tools, practices, solutions, opportunities, and challenges through a variety of platforms. It contributes to a shared understanding and effective approach to business solutions to global challenges,

sustainable business practices in the region, as well as the challenges and opportunities for partnership approaches. It seeks to build linkages with organizations and networks with similar missions in the region and actively explores collaboration opportunities to maximize impact towards its mission.

10.3.9 Professional Master's Degree in CSR

As CSR is only slowly being integrated into the curricula of MBAs and other management qualifications in Asia and globally, many executives tasked with a CSR portfolio do not have formal training and specialised expertise to deliver on meaningful CSR programmes linked to core business strategies. In partnership with CSR Asia, delivered through AIT's School of Management, and coordinated by the CSRACA, AIT is pioneering a flexible executive style professional Master's degree in CSR to respond to this capacity gap. Modules will be delivered at AIT starting in September 2011. Three of eight intensive modules that comprise the taught part of the program and that will be delivered at least once per year are scheduled for 2011.

The objective of the degree is to provide participants with professional competencies and skills in the fields of sustainable development and CSR. It is designed to help build the capacity necessary to ensure that the business sector is better prepared to manage global sustainability challenges responsibly and contribute to the achievement of targets such as the Millennium Development Goals in a dynamic, competitive business environment. The program is the first of its kind in Asia and a timely initiative that will help meet the capacity gap within firms and other organizations to deliver on CSR programs that meet business needs for long-term competitiveness whilst contributing to sustainable development in the Asia Pacific region.

10.3.10 Activities Carried out in 2010

A) One-day CSR Asia training courses

- **Reporting and Communications, 20 April 2010, co-delivered at the CSR Asia office in Kuala Lumpur**
A practical training course on international reporting standards and how to manage and report sustainability performance effectively to support business objectives and meet stakeholder demands for transparency and accountability:
 - Identifying the key issues on which to report
 - Transparency and accountability
 - Developing priorities through stakeholder engagement
 - International reporting standards
 - Global Reporting Initiative
 - Tools and strategies to deliver an effective sustainability message
 - Tailoring reporting solutions to meet a company's unique needs
 - Measuring and reporting on community investment
 - Reporting CSR activities to key stakeholders
 - Developing an effective communications plan
 - Case studies of successful reporting strategies
- **Building Partnerships with Business for Development, 14 June 2010**
Total Contracted Amount (THB): 87,945
The purpose of this course is to support development agencies (International Organisations, NGOs, and government agencies) to be better prepared to work with companies on partnerships for sustainable development. A basic introduction to CSR geared

towards the needs of the non-profit sector will be provided followed by an in-depth look at the different ways to engage with companies. Participants will be able to reflect on and build their strategy for engaging with business on sustainable development challenges and be better equipped for approaching businesses and writing proposals aligned with company interests.

- **Investing for Impact, 12 July 2010**
Total Contracted Amount (THB): 47,918
It is important that company's community investment adds value for communities and for the business. This interactive and participatory workshop is designed to give people responsible for CSR and Community investment the background and the tools to improve the quality of their work and the impact it can make. The first part examines approaches, lessons learned, case studies, and engaging employees in the whole process while the second part focuses on monitoring and evaluation and measuring for outcomes and impact.
 - Learn about best practice in companies contributions to poverty alleviation
 - Identify opportunities and partnerships which make sense for your company
 - Engage community stakeholders
 - Understand how employee volunteering can play a role
 - Learn how to measure inputs, outputs and impact
- **CSR Essentials, 23 August 2010**
Total Contracted Amount (THB): 66,794
A highly practical course to get participants started on CSR. After examining the emerging

CSR agenda it outlines seven practical tools for effective implementation of CSR:

- CSR policy and governance
- Stakeholder engagement
- Environmental assessments
- Supply chain codes of conduct
- Community investment and evaluation
- CSR and human resource management
- Reporting and communications

- **ISO 26000**, 1 November 2010
Total Contracted Amount (THB): 58,614.70
ISO 26000 is the new guideline from the International Organisation for Standardization (ISO) specifically focusing on social responsibility that is set to shape the future of responsible business. This CSR Asia training course is designed to help companies integrate the guidance into their management systems and operations. The training outlines the scope and rationale of ISO 26000 and address the core social responsibility issues identified. The training also helps to build the competencies of attendees looking to implement the guidelines within their organization by examining the necessary systems and structures, performance reviews and communication required:
 - The social responsibility of the organization
 - Principles of social responsibility
 - Scope and rationale of ISO 26000
 - Stakeholder engagement
 - Guidance on core social responsibility issues
 - Trends in social responsibility
 - Communicating CSR

B) Consultancy and Research Projects

In collaboration with other CSR Asia Offices:

- Consultancy on developing a CSR Strategy for a beverages company in Vietnam through benchmarking, gap analysis, stakeholder engagement, and a workshop
- Research project on Public-Private Partnerships and Disaster Resilience: Presentation of draft working paper and draft principles at an APEC Emergency Preparedness Working Group Workshop on Public-Private Partnerships and Disaster Resilience, 24-27 August 2010, Bangkok
- Contribution to a benchmarking and gap analysis exercise on the local implementation of global CSR strategies of leading multinational conglomerates in Thailand, Malaysia, Vietnam, and Indonesia through a series of interviews with local CSR managers

Led by the CSR Asia Center at AIT:

- Research project on CSR in Thailand conducted in preparation of and disseminated at the official launch of the CSRACA in March 2010
- Research project and CSR Asia Summit session development on assessing the quantitative impact of selected companies with an important presence in Asia on the Millennium Development Goals (MDGs) by means of the MDG Scan, a tool developed by the Dutch NGO NCDO
- Consultancy project on a comprehensive Corporate Social Responsibility (CSR) Initiative for a Hotel Group, including the

development of a CSR policy and strategy, internal workshops and a CSR handbook for employees
Project duration: 1 August 2010 – 1 May 2011

Investigator(s): Ms. Leena Wokeck

Total Contracted Amount (THB): 984,375

- Preparation of a research paper on ICTs and Climate Change Mitigation in the Context of Emerging Economies
Project duration: 14 June 2010 – 31 March 2011
Investigator(s): Ms. Leena Wokeck
Sponsor(s): Innovation and ICTs' Project, The University of Manchester
Total Contracted Amount (THB): 170,424
- Research and Engagement project on Climate Change Adaptation in South and Southeast Asia: Harnessing the Innovative Capacity of the Private Sector
Project duration: 1 July 2010 – 30 May 2011
Investigator(s): Ms. Leena Wokeck
Sponsor(s): Swedish International Development Cooperation Agency (SIDA)
Total Contracted Amount (THB): 2,573,667
- Industry Roundtable on Accelerating HCFC Phase Out: Technological Options, Climate Benefits, and Business Opportunities, held on 9 November 2010 in the margins of the 22nd Meeting of the Parties to the Montreal Protocol in Bangkok
Duration: 1 August 2010 – 31 March 2011
Investigator(s): Ms. Leena Wokeck
Sponsor(s): AIT-UNEP RRC.AP
Total Contracted Amount (THB): 312,500

Key events:

- Internal launch at AIT
2 February 2010
Introduction of the CSRACA and invitation for engagement from across AIT community
- Official public launch of the CSRACA
25 March 2010, FCCT, Bangkok
Very successful standing room only event with over 140 participants and keynotes delivered by HE the Minister of Foreign Affairs of the Kingdom of Thailand, Mr Kasit Piromya, President of SCG Paper, Mr. Chaovalit Ekabut, and AIT Chairman of the Board of Trustees and former Minister of Foreign Affairs HE Dr. Tej Bunnag, as well as AIT President, and CSR Asia Chairman
- CSR Asia Summit
14-15 September 2010
Hong Kong

Other key activities included:

- Attendance and initiation of a multitude of meetings to raise awareness of the newly founded CSRACA and build key relationships with potential partners and clients
- Frequent participation and contribution to events in Thailand and beyond and delivery of numerous presentations on a variety of CSR topics
- Organization and facilitation of a variety of project related and other engagement events

10.3.11 Focus Areas and Plans for 2011 and Beyond

A key focus area for 2011 will be the commencement of the Professional Masters Program in CSR in collaboration with AIT's School of Management, program coordination, marketing, recruitment of participants, and delivery of the first three modules before the end of 2011.

- A second key focus area will be the development and launch of a "Mekong Regional Sustainable Business Round Table"
- Further, engagement activities with companies and business networks in Thailand will be continued with the aim of supporting a variety of capacity building and awareness raising activities, contracting further consultancy projects, and recruiting students for the masters program
- Continued building of a strong network of potential partners
- Continued building of a strong brand for the CSRACA and an excellent reputation as the "place to go" for expertise on CSR and the role of the private sector in sustainable development in Thailand and the Mekong Region
- Intensified internal outreach and exploration of collaboration opportunities with a variety of units across AIT, e.g. through integrating CSR topics in a variety of courses or joint project proposals as appropriate
- In close collaboration with the CSR Asia Director for Research in CSR Asia's Hong Kong office, continue to develop proposals for research projects on the role of the private sector in sustainable development

- Intensified collaboration with the School of Management on the CSR Masters as well as ProSPER.NET
- Contribution to CSR Asia Sustainability Disclosure Forum in Singapore in March and 2011 CSR Asia Summit in Kuala Lumpur in September
- Further focus areas will include:
 - Intensifying knowledge development and capacity building for partnerships with business for development
 - Exploring opportunities and contributing to knowledge development on business solutions to poverty alleviation through market opportunities at the Base of the Pyramid (amongst others in collaboration with the Yunus and ARCMDG Centers at AIT and the Wetlands Alliance)
 - Partnering with expert NGOs on relevant CSR issue areas and developing joint proposals
 - Further research as well as knowledge dissemination, training and capacity building on the role for business in climate change adaptation
 - Driving strategic approaches to Community Investment and launching CSR Asia's Community Investment Round Table in Thailand
 - Convening Industry Round Tables
 - Facilitating multi-stakeholder dialogues

Contact:

Leena Wokeck
Director, CSR Asia Center at AIT
B-109, AIT Conference Center
Email: leena@ait.asia
Phone: +66 2 524 5245

10.4: YUNUS CENTER

10.4.1 Introduction

Despite the progress made in poverty reduction over the last twenty years there still remains a substantial number of people who are poor (1.4 billion living on \$1.25 per day, IFAD Report 2011). The search for effective ways to combat poverty remains an issue that needs urgent attention. The Yunus Center at AIT is the result of a collaborative effort of Nobel Laureate Professor Yunus and the Asian Institute of Technology. Professor Yunus inaugurated the Center in August 2009.

The Center aims to contribute to poverty alleviation by enabling rural people to handle and be in control of improving their own livelihoods. It hopes to provide an independent and open platform for addressing issues in poverty alleviation in a way that has a direct impact on poor people's lives. The Center is devoted to promoting social business as a way of combating poverty. In his book *Building Social Business*, Professor Yunus says the following: "A social business is outside the profit seeking world. Its goal is to solve a social problem by using business methods, including the creation and sale of products or services." Social businesses combine the idealism of grass roots organizations with the efficient methods of businesses.

10.4.2 Mission

The Center aims to contribute to poverty alleviation through the promotion and raising awareness of the ideas and concepts of social business.

10.4.3 Objectives

The objectives of Center as stated in its Charter are given below:

1. The objective of the Yunus Center at AIT is to contribute to poverty alleviation by enabling rural people to handle and be in control of improving their own livelihoods. All activities at the Center shall follow the objective of poverty reduction and sustainability with an initial focus on agriculture and food security issues, encompassing a variety of disciplines and facilitating interdisciplinary work.
2. The Center will provide an independent and open platform for addressing issues in poverty alleviation in a way that has a direct impact on poor people's lives. It will act as an incubator for new social business plans that challenge conventional academic wisdom; it will facilitate generation of community-based knowledge; and it will promote opportunities for both women and men.
3. The Center will serve as an incubator to foster development of approaches to poverty alleviation that are in line with the broad mission of academic institutions but that do not fit within existing academic structures. The Center will work with colleges and universities to transform education institutions into dynamic promoters of change for poverty reduction. The Center can assist these institutions to abandon long-established traditions of academic isolation and become active contributors to sustainable agricultural and rural development through innovative teaching, research and extension.

4. The activities of the Center designed to take advantage of possibly synergies with the teaching, learning, research, and outreach activities in AIT's Schools, Extension, and satellite centers.

10.4.4 Governance

The Center is governed by a Board co-chaired by Professor Yunus and the President of AIT. The Center falls under the administration of the AIT President's Office. The operations of the Center are carried out by a Director under the guidance of the Chairpersons.

10.4.5 Location and Facilities

Yunus Center at AIT is located at the AIT Campus in Pathumthani about 40 Km. North of Bangkok, Thailand. The office facilities are located at ground floor AIT Conference Center.

10.4.6 Activities Carried out in 2010

In pursuing its goals the Center has concentrated on five main areas of activities:

1. The Center has been meeting with people who are interested in social business (business sector, public sector, academics, grass root activists) to engage them in a dialogue about social business. The Center has been doing this through meetings, workshops and talks.
2. The Center has been exploring and discovering potential partners and businesses who are engaged in activities that could be transformed into social businesses
3. The Center has also been facilitating exposure trips to Bangladesh for people from different sectors

(public, private, and academics) who are interested in learning more about social business.

4. The Center has been promoting initiatives that encourage businesses, foundations and others to create social business funds.
5. The Center has hosted interns and volunteers who are interested in researching and working with social business.

In the first half of the year the Center was run by two Interim Directors in succession, while arrangements were made to hire a full time Director. The Center worked with the PRAM project under the Wetlands Alliance Program. This program aimed to train government workers in Laos and give them a university degree.

A full time Director, Dr Riaz Khan took over in the second half of the year. After a meeting with Professor Yunus in Aug 2009, the Center started concentrating on the promotion of the ideas and concepts of social business. The Director is assisted by two Program Organizers Ms. Mya Hpoo Ngone and Mr. Shankar Tagad.

In accordance with these objectives, the Center has been meeting with organizations that are pursuing similar goals. The Center has met with Asoka, Changefusion, PDA, Duang Prateepo Foundation, British Council, Betagro, Mae Fah Lung Foundation, Thammasat Business School, Thailand National Health Commission, etc.

Asoka Innovators for the Public has been a pioneer in the efforts to promote the concept of social entrepreneurs. Asoka fellows are active in many sectors of development work. These include human rights, village entrepreneurship, hospital management etc. Changefusion is another organization in Thailand that is very active in promoting social enterprise. Changefusion has been involved in fostering innovative solutions to social problems by using technologies and social enterprise networks. It has

been involved in helping draft the plans for social enterprise master plan for Thailand. Changefusion also offers financial support to social enterprises through its UnLtd Thailand program. The National Health Commission of Thailand also promotes social enterprise and the Thai Health Promotion Foundation supports initiatives in social ventures. The Thai National Health Commission carries out consultations on the various issues that affect the Thai populace. At the invitation of the NHC, the Center observed the consultation process in Prae Province in Chiang Mai. At the end of 2010, the Center was invited as an observer to the Thailand National Health Assembly which is chaired by the Prime Minister.

The Population and Community Development Association is a well known non-governmental organization that has been active for over three decades in the social enterprise sector. The Duang Prateep Foundation is based in the Klong Toey area and works with the urban poor in Klong Toey. The Foundation has been active in primary education, and special needs education. The Center visited the Klong Toey area to see the activities of the Duang Prateep Foundation. The Center also had a meeting with Director of Operations and COO of Doitung Project and Mae Fah Lung Foundation under Royal Patronage.

Besides the non-governmental sector the business sector has also shown interest in the ideas of social business. For instance Betagro Corporation carries out social activities and the Center visited its social venture operations in Lop Buri. Among the activities was a village development bank, an ideal school kitchen initiative and support to a farmer to increase the productivity of his cassava plantation. The CEO of HSBC also professed a lot of interest in the ideas of social business and invited the Center to give a talk at its office on social business. Among those in attendance were representatives of Nation Multimedia Group, Schneider Electric, Ocean Glass, Citibank, Salamander Energy, Shell Companies in Thailand, and Mobil Hantverk.

The Thammasat Business School has been active in promoting social enterprise projects and has been hosting the annual Global Social Venture Competition in Thailand. The Center was invited to speak at the Social Enterprise Knowledge & Partnership Symposium organized by the British Council and Changefusion. It made a presentation on social business and Grameen Shakti at a Regional Meeting of the Energy and Environment Partnership - Mekong in Vientiane. The Center has coordinated visits of people from the region to see the operations of Grameen Shakti in Bangladesh. The Center supported a doctoral student from AIT who did a project on mushroom growing on rice in straw in Vietnam.

Participation in various Workshops / Conference / Courses

- *General Community Meeting – Danone Community Meeting at Paris France.*
- *Meeting with Professor Yunus, Dhaka Bangladesh.*
- *Certificate Course – Social Business / Enterprise & Poverty conducted by HEC School of Management, Paris France.*
- *Social Business Day, Dhaka Bangladesh. Organized by Yunus Center Dhaka. Attended by representatives from AIT extension.*
- *Global Social Business Summit 2010, Germany organized by Grameen Creative Lab, Germany.*
- *Presentation at ‘Building Partnerships for Implementing Renewable Energy and Energy Efficiency Projects in the Mekong Region (EEP Mekong)’ in Vientiane Laos PDR.*
- *Panelist at a session on social business at the ‘Regional Social Enterprise Knowledge & Partnership Symposium: Social Enterprise for a Sustainable Future in Asia’.* Organized Change Fusion Institute, British Council, and Bangkok BiZNews, and supported by Thai Health Promotion Foundation, Ashoka Thailand, Thai Social

Enterprise Promotion Office and Thai Young Philanthropist Network.

- Presentation on social business at 'Thailand Regional Forum: From Corporate Social Responsibility to Social Entrepreneurship' organized by Data Consult, Bangkok Thailand.
- Judge and mentor for *Global Social Venture Competition, GSVC Business Plan 2011* Organized by Thammasat Business School.
- Presentation on social business and renewable energy at, *Promoting climate friendly bio-energy and food security in the Greater Mekong Sub-region, Renewable Energy and Social Business*. Organized by Food and Agricultural Organization (FAO), Asia Pacific Regional Office and Asian Development Bank (ADB) Thailand Resident Mission Office.
- Talk on Social Business organized by HSBC.
- Invited to be an observer at the *Thailand National Health Assembly 2010* organized by the National Health Commission.

Education / Internship / Research

- Yunus Center at AIT hosted two students namely Michaela Wahlberg and Cecilia Sauma from Södertörn University College, Sweden.
- Yunus Center at AIT hosted a student Mr. Alan Zabihi from Chalmers University, Sweden for one month.
- Yunus Center conducted a session on *Social Business*, during a short course offered by AIT extension.
- Mr Audu Idi Guga, a doctoral student at AIT, carried out a pilot study on the possibility of growing mushroom on rice straw as an income generating activity for small farmers in Vietnam.
- Yunus Center at AIT hosted a team from Financiers without Borders. The team consisted of the Founders Max Glikman and Rodion Lerman. The other members of the team were Dmitriy Berenzon, Ilir Hasi, David Gall and George Georgiev all students from the City University of New York, USA. The team conducted a study on Social Entrepreneurship in

Thailand and produced a report on their findings.

Field Visit / Outreach Activities

- Visit to Lop Buri Province, Thailand to study Village Development Bank, Education Project and Cassava Farm, organized and received by Betagro Group, Thailand
- Visit to Prae Province to study consultative process on health issue organized by National Health Commission, Thailand.
- Visit to Nakorn Si Thammarat Province to study and visit following operations: Mokalan Microfinance Institute, Royal Irrigation project in Pak Phanang river basin, Community Development Projects supported by CORIN Asia Foundation (production of organic fertilizer, biogas and handicrafts from water hyacinth, production of sugar from nipa palm). Visit was organized by CORIN Asia.
- Visit to Grameen Danone yoghurt operations in Bogra, Bangladesh. Visit to Grameen GC Eye Care Hospital in Bogra, Bangladesh.
- Visit to waste recycling and waste dumping site in Bang Phli.
- Visit to Khlong Toey to see primary schools of the Duang Prateep Foundation as well as the credit union development bank in the area.
- Visit to Nang Rong to see the activities of PDA: C&C Restaurant, Mechai Pattana School, VDP in Ban Nong Kradon village

10.4.7 Plans for 2011 and beyond

- The Center hopes to establish some projects in the field and will be exploring small scale energy projects in the Nakhon Si Thammarat region. It will partner with CORIN Asia in this effort.
- The Center will organize a Social Business workshop in partnership with other social enterprise organizations.
- To explore the possibility of a social business sales network for Danone,

Thailand in collaboration with Changefusion.

- Study of the iodine deficiency in Thailand and the educational campaigns to tackle this problem.
- Work on extending a SMS Disease Surveillance System developed by Changefusion. The Center will collaborate with Changefusion and SET at AIT to work on community development in this area.
- Study of village development banks and the state of microfinance in the region.
- The Center will encourage students and professionals to submit plans for implementing a social business. If they are successful in implementing such a business then they can work towards getting the title of Yunus Social Business Fellow.
- The Center has developed a short course on Social Business and will be offering this in partnership with AIT Extension.
- An important part of the Centers activities is to encourage students to work with social business ideas and concepts. The Center will therefore continue to host students as interns and volunteers from AIT and other universities.
- The Center will explore opportunities for collaboration with the schools at AIT namely SET, SOM and SERD.
- The Center will work with AIT Extension especially in the organization of short courses and the development of social business ideas. The Center will work with the CSR Asia Center at AIT and ARCMDG Center at AIT to build up capacity in the area of sustainable development.
- The Center will continue its outreach activities by networking with other organizations with a view to promoting and raising awareness about social business.
- The Center will facilitate visits to Bangladesh to see the social business initiatives of the Yunus Center in Dhaka.

Chapter 11: INSTITUTE-WIDE SPONSORED AND CONTRACTED PROJECTS

Asian Project Management Support Programme

Asian Project Management Support Programme (APMAS) is 3-year regional grant programme starting in 2010, funded by International Fund for Agricultural Development (IFAD) which has been entrusted to AIT as implementing agency. It aims at improving the development effectiveness and efficiency of pro-poor rural development programmes in the Asia and the Pacific region. Its short-term objective is to enhance the management capabilities of IFAD-supported rural development projects and programmes in the region. This will be achieved by (i) building project management capacity; (ii) strengthening the policy environment; and (iii) improving the capacity of service providers. In the implementation, APMAS is also supported by IFAD small-grant of APMAS Gender Sensitive Management (APMAS-GSM) which aims to improve gender sensitivity of IFAD development projects and programmes in the region by developing capacity of local service providers and stakeholders. Within its first phase, APMAS is focusing on 4 target countries namely: Cambodia, India, Laos and Vietnam. Until mid of 2011, APMAS and APMAS-GSM have conducted various capacity building activities, participated by 129 participants of project managers and staff of over 20 IFAD-funded projects, local service providers, national implementing agencies and other relevant stakeholder. Capacity building activities which

APMAS has been performing revolve around the area of project management, monitoring & evaluation, community-driven development and gender mainstreaming. These activities comprise not only regular trainings, but also coaching programme, which allows more intensive interventions and involvement of the target projects, to achieve real impacts in improving of project management performance and gender sensitivity of rural development projects in the respective countries.



Participants discussing group assignment in Community-Driven Development training organized by APMAS

11.1 Grants and Sponsored Research Completed in 2010

“Study Visit Program on Strategic Planning and Pro-Poor growth” conducted in Thailand and Indonesia

Duration: 01 Sep 10 - 31 Dec 10
Project Investigator(s): Jayant K Routray
Sponsor: UNDP Bangladesh
Total Contracted Amount (THB): 550,480

Capacity Building for Poverty Reduction Strategies

Duration: 01 Feb 10 - 31 Aug 10
Project Investigator(s): Jayant K Routray
Sponsor: Government of India
Total Contracted Amount (THB): 1,152,000

ProsPER.Net Project on developing closer linkages to poverty reduction

Duration: 01 May 10 - 01 Dec 10
Project Investigator(s): Hans Guttman
Sponsor: ProsPER.Net
Total Contracted Amount (THB): 672,000

Training Workshop Thematic Research on Gender mainstreaming and Economic empowerment

Duration: 06 Feb 09 - 30 Nov 10
Project Investigator(s): Jayant K Routray
Sponsor: UNIFEM
Total Contracted Amount (THB): 1,650,000

11.2 On-going Grants and Sponsored Research

Asian Project Management support Programme

Duration: 01 Jan 10 - 30 Jun 13
Project Investigator(s): Sudip K Rakshit, S Venkatesh, Mokbul Ahmad, Kyoko Kusakabe, Philippe Doney
Sponsor: IFAD
Total Contracted Amount (THB): 45,150,000

Capacity Building of Faculty of Engineering, Balkh University, Afghanistan

Duration: 01 Jan 08 - 30 Jun 11
Project Investigator(s): Naveed Anwar

Sponsor: Balkh University, Ministry of Higher Education, Islamic Republic of Afghanistan
Total Contracted Amount (THB): 42,979,260

Development Planning & Governance for Poverty Reduction

Duration: 01 Oct 10 - 30 Mar 11
Project Investigator(s): Jayant K Routray
Sponsor: Government of India
Total Contracted Amount (THB): 2,240,250

Gender mainstreaming and equality with focus on MDG’s

Duration: 26 Nov 10 - 25 Mar 11
Project Investigator(s): Jayant K Routray
Sponsor: UNDP Afghanistan
Total Contracted Amount (THB): 1,102,000

International Conference on Sustainability Science (ICSS-Asia)

Duration: 01 Jul 09 - 30 Jun 11
Project Investigator(s): Vilas Wuwongse
Sponsor: University of Tokyo Japan
Total Contracted Amount (THB): 965,440

The Advance International Training Program "Putting Ideas to work strategies for Innovation led Sustainable growth" ITP 2010

Duration: 01 Mar 10 - 28 Feb 11
Project Investigator(s): Sudip K Rakshit
Sponsor: VINNOVA
Total Contracted Amount (THB): 743,325

URC TNA Project

Duration: 09 Sep 10 - 31 May 12
Project Investigator(s): Sudip Kumar Rakshit
Sponsor: UNEP Riso Center Denmark
Total Contracted Amount (THB): 4,516,024

Wetland Alliance Aqua Outreach Program

Duration: 01 Jun 09 - 31 Dec 11
Project Investigator(s): Theo Ebbers
Sponsor: SIDA
Total Contracted Amount (THB): 11,086,333

Wetland Alliance Secretariat

Duration: 01 Jun 09 - 31 Dec 11
Project Investigator(s): Hans Guttman
Sponsor: SIDA
Total Contracted Amount (THB): 18,529,145

Workshop on "Doing Business in Africa"

Duration: 01 Sep 07 - 31 Dec 11
Project Investigator(s): Vilas Wuwongse
Sponsor: Ministry of Foreign Affairs (MFA) Thailand
Total Contracted Amount (THB): 2,194,280

AIT Research Strategy Development

Duration: 01 July 10 - 31 July 11
Project Investigator(s): Sudib K. Rakshit
Sponsor: SIDA
Total Contracted Amount (THB): 1,540,428



APMAS and APMAS-GSM always put efforts to mainstream gender in all development aspects. In this picture participants attending APMAS Training on Gender-Sensitive Value Chain, which aims to impart practical tools and methods in upgrading value chain in IFAD-funded projects. This training was possible with the collaboration between APMAS-GSM and ILO.

Chapter 12: OVERVIEW OF RESEARCH ACTIVITIES FOR 2010 AND STUDENT COMPETITIONS

12.1 OVERVIEW OF RESEARCH ACTIVITIES FOR 2010

Overall during the period January to December of 2010 there were **456** sponsored and contracted projects which were conducted by the faculty and staff from within the Fields of Study (FoS) of the three schools, SET, SERD and SOM, as well as in AIT Extension, IntERLab, and Institute wide projects. The total Publications for the same period stood at **691** from across AIT. The breakdown of which is indicated in the table below.

SCHOOL/FoS	SPONSORED & CONTRACTED PROJECTS		TOTAL PROJECTS	PUBLICATIONS				TOTAL PUBLICATIONS
	Completed	On-going		Refereed Journals	Conference Proceedings	Refereed Books/ Chapters	Other Publications	
SET	65	85	150	177	102	3	1	283
SET	1		1					0
ACECOMS	4	1	5	2				2
GIC	4	7	11					0
CS/IM	5	8	13	15	25	1	1	42
CEIM	5	4	9	8				8
GTE	11	7	18	24				24
IME	4	7	11	18	9			27
Mech/MES	5	8	13	10	4			14
Nano	1	5	6	6	23	1		30
RSGIS	3	9	12	15				15
StE	6	6	12	15				15
TC	1	1	2	15	35			50
TrE	3	7	10	7				7
WEM	12	14	26	41	6	1		48
OTM		1	1	1				1
SERD	57	81	138	211	68	23	52	354
SERD		1	1					0
ASE	2	7	9	18				18
AARM	1	7	8	11	8			19
E	9	17	26	38	25		1	64
EEM	12	26	38	60	16	10	31	117
FEBT	8	6	14	13	12	2		27
GDS	4	10	14	11			4	15
NRM	7	4	11	19				19
PPT			0	8	1			9
RRDP	2		2	16	1	6	1	24
UEM	12	3	15	16	5	5	15	41
ABM			0	1				1
DPMM		1	1		4	3		7
SOM	4	18	22	34	7			41
intERLab	7	6	13	1				1
AIT Ext	88		88					0
SDCC		3	3					0
ARCMDG		11	11					0
CSRACA	5	9	14					0
Inst-wide	4	12	16					0
TOTAL	230	226	456	423	174	36	53	686

For the same period January to December of 2010 there was a total of **76** Doctoral Dissertations which were undertaken by the faculty from within the Fields Study (FoS) of the three schools, SET, SERD and SOM. The total Masters Student Research for the same period stood at **680** from within the three schools. The breakdown of which is indicated in the table below.

SCHOOL/FoS	DOCTORAL STUDENTS' DISSERTATION	MASTERS STUDENTS RESEARCH				TOTAL MASTERS STUDENTS RESEARCH
		Thesis	Research Studies	Projects	Internships	
SET	23	187	58	64	7	316
CS/IM	6	13	9			22
CEIM	3	17		42		59
GTE		15	13			28
IME	2	13		22		35
Mech/MES	2	17	2			19
RSGIS		10				10
StE	2	25				25
TC	3	15	8			23
TrE	2	8	10			18
WEM	3	23	1			24
ICT		17	15			32
OTM		14			7	21
SERD	44	193	12	2	0	207
ASE	2	11				11
AARM	5	15	1			16
E	4	32	2			34
EEM	7	26				26
FEBT	3	32	2			34
GDS	2	15	1			16
NRM	9	15	1			16
PPT	1	10		2		12
RRDP	7	9	3			12
UEM	4	23				23
ABM		5	2			7
DPMM		6				6
GTD		5	1			6
SOM	9	29	122			151
TOTAL	76	391	100	188	7	686

12.2 STUDENT COMPETITIONS

12.2.1 MASTERS THESIS COMPETITION 2010

The 5th AIT Masters Theses Competition was held on the 17th of May 2010. There were seven competition categories (see below) and students with excellent grades in their theses were nominated to represent their respective fields of study. Theses presentations have been judged according to the relevance; originality; scientific/society contribution; general knowledge of the field; future potential for innovation; and presentation skills. A total of 55 students participated in the competition. There were 19 judges from industry, developmental agencies, international organizations, universities, etc. A number of activities and possibilities including employment, projects, interaction with other organizations, press coverage, etc. spun off from the competition.

The winners of the respective categories were the following:

Category	Name / Title of Presentation	Advisor
Resources	Mr Yadhu Nath Guragain "New pretreatment methods for lignocellulosic residue for second generation bioethanol production"	Prof Sudip K Rakshit
Civil Engineering	Miss May Phyo Aung "Development of Post-Tensioned Precast Concrete Building Systems for Seismic Resistance"	Dr. Pennung Warnitchai
ICT	Miss Sraddha Adhikari "Content Discovery Using People Social Pattern in Peer-to-Peer Networks"	Dr Teerapat Sanguankotchakorn
Development	Miss Duangsamorn Jatupornpimol "State Response to Intimate Partner Violence in Thailand"	Dr Philippe Doney
Information Systems	Mr Sarayut Amornwongpeeti "A Fourth-Order Cascaded Multi-Bit Delta-Sigma Modulator with Interstage Feedback Paths"	Dr. Mongkol Eakpanyapong
Management	Mr Pongthep Vichaikul "Degree of Family ownership and the firm performance, A study of listed company in Thailand"	Dr Sundar Venkatesh
Energy/Environment	Miss Kaushalya C. Wijekoon "High Rate Thermophilic Anaerobic Membrane Bioreactor for Wastewater Treatment"	Prof C Visvanathan

12.2.2 AIT V.RESEARCH COMPETITION 2010

The second AIT v.research Competition, an initiative to encourage student researchers to hone their ability to convey an idea in a clear, concise and entertaining way, was carried out during the period from 9 April to 17 May 2010. All AIT students were invited to be a part of the next generation of "AIT Film Makers" by composing and producing a 3-minute video about their thesis. Students worked as a team or went solo, provided that only one thesis work was covered per video. Music, narration and other media styles were used to enhance their videos.

Organized by the Office of Vice President for Academic Affairs, the AIT Student Office and the Media and Communications Unit (MCU), the event was supported by the AIT Alumni Association, the AIT Student Union, and the Office of the President, respectively.

Ms Aarthy Sivapunniyam was declared the winner of the second AIT v.research competition. The award winning video titled "*Gas sensor based on nanostructures*" was the judge's choice and won the grand prize. The video based on her research as a student of Microelectronics in the School of Engineering & Technology (SET) focused on how gas leakage disasters could be avoided using sensors based on nanotechnology. Her research was carried under the supervision of Prof. Joydeep Dutta, Director, Center for Excellence in Nanotechnology at AIT.

The video on "*Super GABA rice*" by **Mr. Ekkapong Cheevitsopon**, a student of Food Engineering & Bioprocess Technology in AIT's School of Environment, Resources & Development (SERD) was declared the winner in category of "technical expertise". His research was conducted under the supervision of Prof. Athapol Noomhorm, Coordinator, Food Engineering & Bioprocess Technology Field of Study.

Mr. Chanchal Saha, of Industrial & Manufacturing Engineering from SET with his video "*Spinning Around*" was the winner of the People's Choice award. His research supervisor is Dr. Huynh Trung Luong. His team comprised of fellow IME students **Mr. Chawit Chongwilaiwan** and **Ms. Tharinan Rattanalet**.

Ms. Nguyen Thi Thuy of Environmental & Engineering Management (SERD) won the President's choice award. Her video was titled, "*Human powered drinking water treatment*" and her thesis supervisor is Prof C Visvanathan.

The eight entries were evaluated by a panel of five judges including the Vice President for Academic Affairs, Prof. Peter Haddawy; Vice President for Research, Prof. Sudip K Rakshit; Mr. Shane Muangkroot, representative of AIT Alumni Association; Mr. Les Nordhauser, Managing Partner, Greenlight Films; and Ms. Nathaporn Karnjanapoomi, Lecturer, Faculty of Information and Communication Technology, Silpakorn University.

Prof. Haddawy complimented the participants and stated that the quality of videos produced by students was remarkably higher than the previous year. "*It was very difficult judging the videos, since each one has its own distinctive style,*" he remarked. Mr. Les Nordhauser appreciated the initiative and remarked that the video competition is akin to a one minute presentation. Ms. Nathaporn remarked that the content and the message was the most important element while producing a video. Mr. Shane, who has worked in the media industry, stated that the quality of video produced by AIT students was of a professional level and could be used for wider broadcast in the Thai media. Prof. Rakshit stressed the need for effective communications for scientists and researchers. Managing Director of Royal Broadcasting Station, Mr. Sompop Punsri along with his team also participated in the event and offered a partnership in broadcasting the AIT student videos.